

PRODUCT SPECIFICATION

FOR

™

WREN V SCSI

MODEL 94181

SUMMARY

The CDC WREN™ Peripheral family is composed of the following members. For specific information on each member, refer to the appropriate documents.

NAME	MODEL NUMBER *	PRODUCT SPECIFICATION	INTERFACE	CAPACITY (MEGABYTES)
WREN II	94155-XX	77715909	CDC 506 (ST506 COMP.)	57, 67, or 86 (925 Cyl)
WREN II	94155-XX	77738379	CDC 506 (ST506 COMP.)	85 or 96 (1024 Cyl)
WREN II	94155-XXX	77765324	CDC 506 (ST506 COMP.)	120, 135 (RLL)
WREN II	94156-XX	77738019	ESDI	48, 67 or 86
WREN II HH	94205-XX	77738213	CDC 506 (ST506 COMP.)	30, 41, 51, 77 (RLL)
WREN II HH	94204-YY	77738346	CDC 506 (ST506 COMP.)	65
WREN III	94166-XXX	77738212	ESDI	101, 141 or 182
WREN III	94161-YYY	77738270	SCSI **	86, 121 or 155 (512 Byte)
WREN III HH	94211-YY	77765250	SCSI **	94 (1024 Byte)
WREN III HH	94216-XXX	77765276	ESDI	106
WREN IV	94171-YYY	77738386	SCSI **	320 (1024 Byte)
WREN IV	94171-344	77765338	SCSI **	344 (1024 Byte)
WREN IV	94171-YYYD	77765361	SCSI **	345 (1024 Byte)(Dif. I/O)
WREN V	94186-442	77765300	ESDI	442 (15 Head)
WREN V	94186-383			383 (13 Head)
WREN V	94186-383H			383 (15 Head, 1224 Cyl)
WREN V	94181-XXX	77765336	SCSI **	702
WREN V HH	94221-YYY	77765297	SCSI **	169, 190 (1024 Byte)
WREN VI	94191-XXX	77765353	SCSI **	766
WREN VI	94196-XXX	77765358	ESDI	766

* XX(X) denotes unformatted drive capacity in megabytes. For example, Model number 94166-182 is a WREN III with ESDI Interface and an unformatted capacity of 182 megabytes.

YY(Y) denotes formatted drive capacity.

** These drives allow the user to reformat using any integer data block size between 256 and 2048 bytes (WREN III) or 4096 bytes (WREN IV, V). At the factory drives are formatted with 512 byte data block size, with capacity dependent on number of data heads. Capacity values are with limited spares for reallocation of defects.

TABLE OF CONTENTS

1.0	SCOPE.....	9
2.0	APPLICABLE DOCUMENTS.....	9
	2.1 STANDARDS.....	9
	2.2 DOCUMENTATION.....	11
	2.2.1 Applicable Documents.....	11
	2.2.2 Reflected Changes.....	11
3.0	GENERAL DESCRIPTION.....	12
4.0	FEATURES.....	14
	4.1 STANDARD FEATURES.....	14
	4.2 UNFORMATTED AND FORMATTED CAPACITIES.....	14
	4.3 OPTIONS (factory installed).....	15
	4.4 OPTIONAL ACCESSORIES (user installed).....	15
5.0	PERFORMANCE CHARACTERISTICS.....	16
	5.1 INTERNAL DRIVE CHARACTERISTICS (Transparent to User).....	16
	5.2 SCSI DRIVE SEEK, READ AND WRITE PERFORMANCE CHARACTERISTICS (Visible to User).....	16
	5.2.1 Seek Command Execution Time.....	17
	5.2.2 Format Drive Command Execution Time.....	17
	5.2.3 Read Data Command Execution Time.....	17
	5.2.4 Write Data Command Execution Time.....	18
	5.3 GENERALIZED PERFORMANCE CHARACTERISTICS.....	18
	5.3.1 Notes.....	19
	5.4 START/STOP TIME.....	20
	5.5 READ LOOK-AHEAD.....	21
6.0	RELIABILITY SPECIFICATIONS.....	22
	6.1 ERROR RATES.....	22
	6.1.1 Read Errors.....	22
	6.1.2 Environmental Interference.....	23
	6.1.3 Write Errors.....	23
	6.1.4 Seek Errors.....	23
	6.2 RELIABILITY AND SERVICE.....	24
	6.2.1 Mean Time Between Failure.....	24
	6.2.2 Preventive Maintenance.....	24
	6.2.3 Service Life.....	24
	6.2.4 Service Philosophy.....	24
	6.2.5 Installation.....	24
	6.2.6 Service Tools.....	25
7.0	PHYSICAL/ELECTRICAL SPECIFICATIONS.....	25
	7.1 AC POWER REQUIREMENTS.....	25
	7.2 DC POWER REQUIREMENTS.....	25
	7.2.1 Power Sequencing.....	26
	7.2.2 12 V Current Profile.....	26
	7.3 HEAT/POWER DISSIPATION.....	28
	7.4 ENVIRONMENTAL LIMITS.....	28
	7.4.1 Temperature.....	29
	7.4.2 Relative Humidity.....	30

TABLE OF CONTENTS (continued)

7.4.3	Effective Altitude (Sea Level Ref).....	30
7.4.4	Shock and Vibration.....	30
7.4.5	Air Cleanliness.....	33
7.5	MECHANICAL SPECIFICATIONS.....	34
7.5.1	Drive Orientation.....	34
7.6	ACOUSTIC NOISE LEVEL.....	34
7.7	MECHANICAL SPECIFICATIONS.....	35
7.7.1	Drive Orientation.....	36
7.7.2	Cooling.....	36
8.0	MEDIA CHARACTERISTICS.....	36
8.1	MEDIA DESCRIPTION.....	36
9.0	DEFECT AND ERROR MANAGEMENT.....	36
9.1	WREN V INTERNAL DEFECTS/ERRORS.....	37
9.2	SCSI SYSTEMS ERROR CONSIDERATIONS.....	37
10.0	INTERFACE REQUIREMENTS AND OPTIONS.....	38
10.1	GENERAL DESCRIPTION.....	38
10.2	DC CABLE CONNECTOR.....	40
10.3	PHYSICAL CHARACTERISTICS.....	41
10.3.1	Physical Description.....	41
10.3.2	Cable Requirements.....	42
10.3.3	Connector Requirements.....	42
10.3.4	Electrical Description.....	45
11.0	SCSI BUS.....	48
11.1	SCSI BUS SIGNALS.....	49
11.1.1	Signal Values.....	50
11.1.2	OR-Tied Signals.....	50
11.1.3	Signal Sources.....	52
11.2	SCSI BUS TIMING.....	53
11.2.1	Arbitration Delay (2.2 us).....	53
11.2.2	Assertion Period (90 ns).....	53
11.2.3	Bus Clear Delay (800 ns).....	53
11.2.4	Bus Free Delay (800 ns).....	53
11.2.5	Bus Set Delay (1.8 us).....	53
11.2.6	Bus Settle Delay (400 ns).....	54
11.2.7	Cable Skew Delay (10 ns).....	54
11.2.8	Data Release Delay (400 ns).....	54
11.2.9	Deskew Delay (45 ns).....	54
11.2.10	Hold Time (45 ns).....	54
11.2.11	Negation Period (90 ns).....	54
11.2.12	Reset Hold Time (25 us).....	54
11.2.13	Selection Abort Time (200 us).....	54
11.2.14	Selection Timeout Delay (250 ms recom.).....	55
11.2.15	Transfer Period (Message phase).....	55

TABLE OF CONTENTS (continued)

12.0	LOGICAL CHARACTERISTICS.....	55
12.1	SCSI BUS PHASES.....	55
12.1.1	BUS Free Phase.....	57
12.1.2	Arbitration Phase.....	58
12.1.3	Selection Phase.....	58
12.1.4	Reselection Phase.....	60
12.1.5	Information Transfer Phases.....	62
12.1.6	Command Phase.....	65
12.1.7	Data Phase.....	65
12.1.8	Status Phase.....	66
12.1.9	Message Phase.....	66
12.1.10	Signal Restrictions Between Phases.....	67
12.2	SCSI BUS CONDITIONS.....	68
12.2.1	Attention Condition.....	68
12.2.2	Reset Condition.....	60
12.3	SCSI BUS PHASE SEQUENCES.....	70
12.3.1	Nonarbitrating System.....	70
12.3.2	Arbitrating Systems.....	70
12.3.3	All Systems.....	70
12.4	SCSI POINTERS.....	71
12.4.1	Current Pointers.....	72
12.4.2	Saved Pointers.....	73
12.5	MESSAGE SYSTEM SPECIFICATION.....	74
12.5.1	Message Protocol.....	74
12.5.2	Messages.....	75
12.5.3	Extended Messages.....	80
12.5.4	Synchronous Data Transfer Request.....	80
13.0	SCSI COMMANDS.....	83
13.1	COMMAND IMPLEMENTATION REQUIREMENTS.....	84
13.1.1	Reserved.....	84
13.1.2	Operation Code Type.....	85
13.1.3	Unit Attention Condition.....	85
13.1.4	Command Queing.....	86
13.2	COMMAND DESCRIPTOR BLOCK (CDB).....	87
13.2.1	Operation Code.....	87
13.2.2	Logical Unit Number (LUN).....	89
13.2.3	Logical Block Address.....	89
13.2.4	Relative Address Bit.....	90
13.2.5	Transfer Length.....	90
13.2.6	Control Byte.....	91
13.3	COMMAND EXAMPLES.....	91
13.3.1	Single Command Example.....	91
13.3.2	Disconnect Example.....	92
13.4	TIMING EXAMPLES.....	94
13.5	WREN V SCSI TIMING.....	109

TABLE OF CONTENTS (continued)

14.0	COMMAND DESCRIPTIONS.....	111
14.1	COMMAND DESCRIPTIONS FOR ALL DEVICE TYPES.....	111
14.1.1	Group 0 Commands for All Device Types...	111
14.1.1.1	Test Unit Ready.....	112
14.1.1.2	Request Sense Command.....	113
14.1.1.3	Inquiry Command.....	121
14.1.1.4	Copy Command.....	124
14.1.1.5	Receive Diag. Results Command.	124
14.1.1.6	Send Diagnostic Command.....	128
14.1.2	Group 1 Commands for All Device Types...	129
14.1.2.1	Compare Command.....	129
14.1.2.2	Copy and Verify Command.....	129
14.1.2.3	Write Data Buffer Command.....	130
14.1.2.4	Read Data Buffer Command.....	133
14.1.3	Group 2 through 5 Commands for All Device Types.....	135
14.1.4	Group 6 Commands for All Device Types...	135
14.1.5	Group 7 Commands for All Device Types...	135
14.2	COMMAND DESCRIPTIONS FOR DIRECT ACCESS DEVICES..	136
14.2.1	Group 0 Commands for Direct Access Devices.....	136
14.2.1.1	Rezero Unit Command.....	137
14.2.1.2	Format Unit Command.....	138
14.2.1.3	Reassign Blocks Command.....	145
14.2.1.4	Read Command.....	147
14.2.1.5	Write Command.....	149
14.2.1.6	Seek Command.....	151
14.2.1.7	Mode Select Command.....	152
14.2.1.8	Reserve Command.....	157
14.2.1.9	Release Command.....	160
14.2.1.10	Mode Sense Command.....	161
14.2.1.11	Start Unit Command.....	181
14.2.1.12	Prevent/Allow Medium Removal Command.....	182
14.2.2	Group 1 Command for Direct Access Devices.....	182
14.2.2.1	Read Capacity Command.....	183
14.2.2.2	Read Extended Command.....	184
14.2.2.3	Write Extended Command.....	186
14.2.2.4	Seek Extended Command.....	188
14.2.2.5	Write and Verify Command.....	189
14.2.2.6	Verify Command.....	191
14.2.2.7	Search Data Commands.....	192
14.2.2.8	Set Limits Command.....	192
14.2.2.9	Read Defect Data Command.....	193
15.0	STATUS.....	197

TABLE OF CONTENTS (continued)

16.0	ERROR RECOVERY PHILOSOPHY.....	198
	16.1 SEEK ERRORS (09 or 15 HEX ERROR CODE).....	199
	16.2 DATA FIELD WRITE FAULT (03 HEX ERROR CODE).....	199
	16.3 SYNC BYTE ERROR (12 HEX ERROR CODE).....	200
	16.4 DATA FIELD ECC ERROR (11 Hex or 18 Hex Error Code).....	200
	16.5 ALTERNATE SECTOR PROCESSING.....	201
17.0	OPTIONS.....	202
	17.1 FRONT PANEL.....	202
	17.2 SINGLE UNIT SHIPPING PACK.....	202
	17.3 DRIVE TERMINATION.....	202
18.0	ACCESSORIES.....	203
	18.1 FRONT PANEL KIT.....	203
	18.2 OEM MANUAL.....	203
APPENDIX A	SCSI Protocol Error Handling FLOW Charts.....	204

1.0 SCOPE

This specification describes the Control Data Corporation Model 94181 WRENTM V Disk Drive. This high capacity, high performance, member of the 5 1/4 inch WREN rigid disk family incorporates the standard WREN V HDA (Head/Disk Assembly) and has an embedded SCSI controller. Performance information is given in Section 5. The Model 94181 interface is defined for functional compatibility to the mandatory subset of the CDC SCSI Interface Specification (which is compatible with the ANSI SCSI standard and the Common Command Set (CCS) document, Revision 4.B). The Model 94181 WREN is classified as an "Intelligent" peripheral. The WREN V provides Level 2 conformance (highest level) with the ANSI SCSI standard. Details of SCSI options are provided in Section 5, and 10 thru 16.

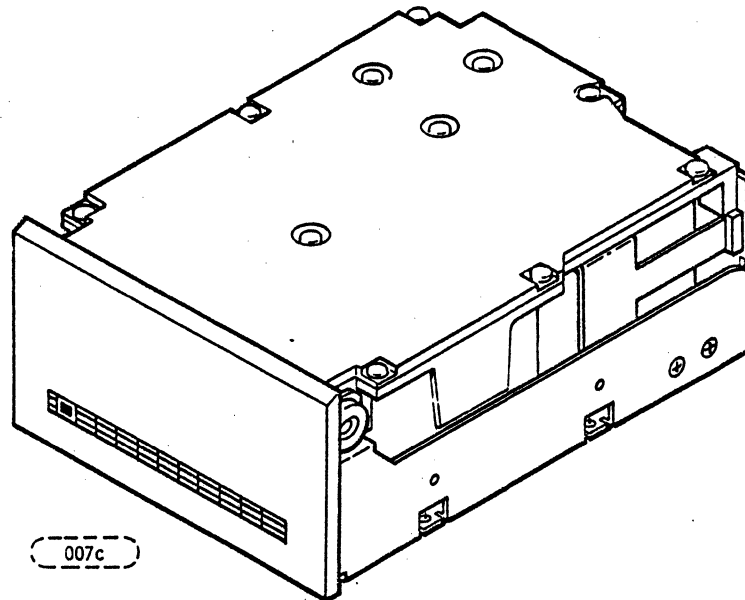

FIGURE 1.0-1. 94181 WREN V

2.0 APPLICABLE DOCUMENTS

2.1 STANDARDS

The WREN V has been developed as a system peripheral to the highest standards of design and construction. The WREN V depends upon its host equipment to provide adequate power and environment in order to achieve optimum performance and compliance with applicable industry and governmental regulations. Special attention must be given in the areas of safety, power distribution, shielding, audible noise control, and temperature regulation.

2.1 (continued)

The WREN V complies with CDC standards as noted in the appropriate sections of this specification.

The WREN V is a UL Recognized component per UL 478 and a CSA Certified component per CSA C22.2 No. 154-M1983. It also meets the requirements of DIN IEC 380/VDE 0806/8.81.

The WREN V, as delivered, is designed for system integration before use. It is supplied as a Class A Computing Device per the FCC Rules and Regulations, Part 15, Subpart J governing EMI of computing devices.

CAUTION

To avoid potential service problems, observe the following precautions:

- Labels must not be put over the breather holes on the top of the drive.
- If a label has been placed over the breather holes, do not poke holes through the label, as the filter underneath is certain to be damaged, allowing contamination to enter. REMOVE THE LABEL. Do not use solvents to remove the adhesive residue. Small amounts of solvent may migrate down the breather holes and contaminate the disk.
- CDC/MPI factory installed labels must not be removed from the drive or covered with additional labels, as they contain information required when servicing the product.
- DC power should not be switched on to the drive by plugging an electrically "live" DC source cable into the drive power connector. This practice adversely affects the reliability of the connector contacts.

2.2 DOCUMENTATION

2.2.1 Applicable Documents

77765337 OEM Manual
64721700 CDC Small Computer System Interface (SCSI)
ANSI Small Computer System Interface (SCSI): Document
Number ANSI3.131-1986 (X3T9/84-40 Rev. 1B) (X3T9.2/82-2
Rev. 17B).

In case of conflict between this document and any
referenced document, this document shall take precedence.

2.2.2 Reflected Changes

Changes to individual pages of this specification are
reflected in the revision letter at the top right corner of
the page, after the part number. The revision letter
applies to that page only and does not change unless a
change was made on the page, in which case it takes the
latest revision letter of the specification. In comparing
different revisions of the specification, note that the
pages with the same revision letters as the specification
were the one changed to achieve that particular
specification revision.

3.0 GENERAL DESCRIPTION

The WREN V is a member of a family of low cost, high performance, highly reliable, random access storage devices designed to meet the needs of the OEM marketplace.

The WREN V is designed to record and recover data on eight 5-1/4 inch (130 mm) fixed disks.

The Model 94181 WREN V supports the Small Computer System Interface (SCSI) as described in Control Data's SCSI Specification (64721700). The information contained in this product specification defines the product performance characteristics and the interface characteristics of the Model 94181 WREN V.

The Model 94181 WREN V SCSI interface supports multiple initiators, disconnect/reconnect, self configuring host software and automatic features that relieve the host from the necessity of knowing the physical characteristics of the targets (logical block addressing is used).

The Head, Disk and Actuator chamber (HDA) is environmentally sealed at the factory. Air is recirculated within the HDA through a nonreplaceable filter to maintain a contamination free disk/actuator environment.

Refer to Figure 3.0-1 for an exploded view of the WREN V. NEVER disassemble the WREN Head/Disk Assembly (HDA). This exploded view is for information only. Servicing items in the sealed environmental enclosure (heads, media, actuator, etc.) requires special facilities. The printed circuit boards and hardware external to the sealed area may be replaced without special facilities.

The WREN V uses a dedicated landing zone at the innermost radius of the media thus eliminating the possibility of destroying or degrading data by landing in the data zone.

The WREN V incorporates an automatic shipping lock which prevents potential damage to the heads and disks caused by movement during shipping and handling. The shipping lock is automatically disengaged when power is applied to the drive.

The WREN V decodes Track 0 location from the dedicated servo surface thereby eliminating mechanical transducer adjustments and related reliability concerns.

The WREN V uses a high performance actuator assembly consisting of a low inertia, balanced, patented, straight arm design which provides excellent performance with minimum power dissipation.

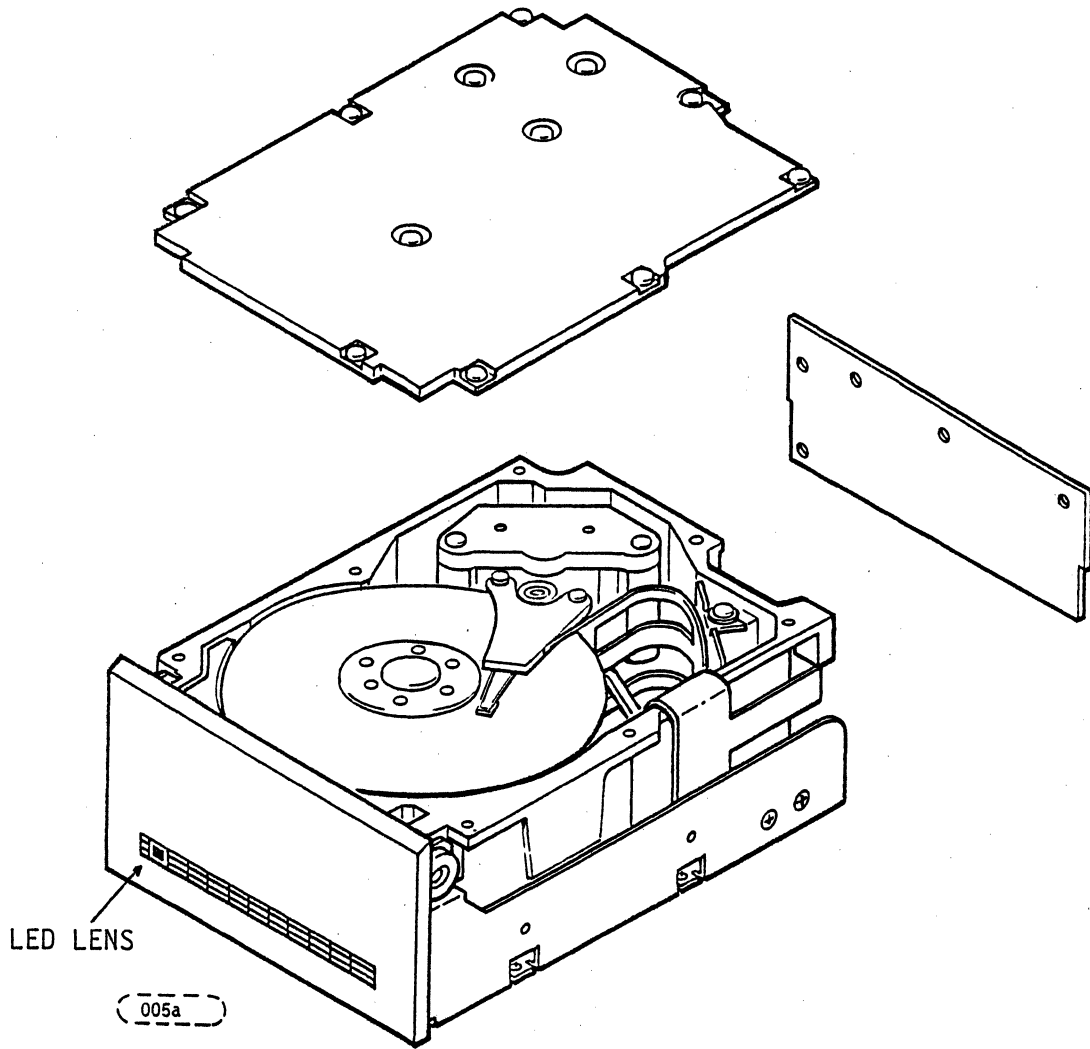

FIGURE 3.0-1. MODEL 94181 WREN V

4.0 FEATURES

4.1 STANDARD FEATURES

The Model 94181 WREN V has the following standard features:

- Integrated SCSI Controller
- Single ended SCSI drivers and receivers
- Asynchronous SCSI bus data transfer protocol
- Synchronous SCSI bus data transfer protocol
- 32 kilobyte data buffer
- Read Look-ahead Buffer Management
- Selectable data block size
- Flawed sector reallocation at format time
- Reallocation of defects on command (Post Format)
- Selectable automatic reallocation
- User selectable reallocation sector locations:
 - On each track, or
 - Within a cylinder, or
 - Within dedicated tracks, or
 - None of the above
- Error Correction (48 bit ECC polynomial)
- 1:1 sector interleave
- Data recovery circuitry contained in the WREN V
- Multiple capacity configurations
- Sealed head, disk and actuator chamber
- No preventive maintenance required
- No adjustments required
- LSI circuitry for high reliability
- Low audible noise for office environment
- Vertical or horizontal mounting
- Low power consumption
- Balanced low mass rotary voice coil actuator
- Automatic shipping lock
- Terminators (accessible without disassembly)
- Integral HDA isolation mounts
- Dedicated head landing zone
- Dynamic spindle braking
- Automatic retries on seek or data read errors (can be disabled)
- Command queing of up to one command per initiator
- Automatic single track seek error correction capability

4.2 UNFORMATTED AND FORMATTED CAPACITIES

Unformatted Capacity

Unformatted capacity of the WREN V is 702 MB

Formatted Capacities

Formatted capacity achieved depends on the number of spare reallocation sectors reserved and the number of bytes per sector. The following table shows some typical formatted capacities achievable.

4.2 continued

Spare Sectors or Cylinders Reserved for reallocation	Sector Size	
	512 Bytes/Sector	1024 Bytes/Sector
No Spares	613 MB	639 MB
One Spare Sector Per Track	601 MB	615 MB
Two Spare Cylinders/Unit*	612 MB	638 MB

*Spare cylinders are on the inner tracks.

4.3 OPTIONS (factory installed)

The following capacities (with limited spare reallocation sectors) are available upon request.

	FORMATTED DATA BLOCK SIZE*		UNFORMATTED
	1024 Byte	512 Byte	
Model 94181-702 (15 Heads)	638 MB	612 MB	702 MByte

*User selectable at format time. The user may modify the data block size before issuing a format command and obtain different formatted capacities than those listed. User available capacity will depend on spare reallocation scheme selected. See Section 14.2.1.7.

The following options are incorporated at the time of production and may be specified for delivery. See Section 17.0.

- Front panel (optional LED lens colors red, amber, green) - See Figure 3.0-1
- Single Unit shipping pack
- OEM Manual
- SCSI Interface Terminating Resistors

4.4 OPTIONAL ACCESSORIES (user installed)

The following accessories are available. All kits may be installed in the field. See Section 18.0.

- Front Panel Kit (optional LED lens colors red, amber, green) - See Figure 3.0-1
- Single Unit shipping pack kit
- OEM Manual

5.0 PERFORMANCE CHARACTERISTICS

5.1 INTERNAL DRIVE CHARACTERISTICS (Transparent to User)

Data Capacity Parameters (unformatted)

Drive Capacity	702 MByte
Read/Write Heads	15 Data (Max)
Bytes/Track	30,170 Bytes (Average)
Bytes/Surface	46.8 Mbyte
Tracks/Surface, Total	1546 Tracks (user accessible)
Tracks/Inch	1280
Bits/Inch	26,000 (Max)
Servo Heads	1
Recording Mode	2,7
Internal Data Transfer Rate	12 - 16 Mbits/second (variable with zone)
	1.5 - 2.0 Mbytes/second (variable with zone)
Disk Rotational Speed	3597 \pm 0.5% r/min
Average Seek Time	16.5 ms Typical

5.2 SCSI SEEK, READ AND WRITE PERFORMANCE CHARACTERISTICS
(Visible to User)

Refer also to Table 13.5-1 for additional timing details.
(see Section 13).

[] Notes are provided in Section 5.3.1 of this document.

5.2.1 Seek Command Execution Time

	<u>Including Controller Overhead (Without Disconnect [1] [4]</u>
Average - Maximum	19.5 ms [2]
Typical	18.0 ms [3]
Single Track - Maximum	5.5 ms [2]
Typical	4.5 ms [3]
Full Stroke - Maximum	43 ms [2]
Typical	40 ms [3]

5.2.2 Format Drive Command Execution Time [1]

Maximum 20 minutes

5.2.3 Read Data Command Execution Time [4] (512 Byte Sector Size and without disconnect). Latency time is included.

- a. From CDB reception to the WREN V request for the first data byte to be transferred to the Host
 - 1. Typical (Zero Stroke Seek) 12.5 ms [3]
 - 2. Typical (Average Seek) 27.0 ms [3]
 - 3. Maximum (Full Stroke Seek) 60 ms [2]

- b. Single Sector Read and Transfer of data to Host (time from receipt of last byte of the CDB to the request for a status byte transfer to Host) assuming a 1:1 interleave [7].
 - 1. Typical (Zero Stroke Seek) 13.5 ms [3]
 - 2. Typical (Average Seek) 28.0 ms [3]
 - 3. Maximum (Full Stroke Seek) 61.0 ms [2]

[] Notes defined in Section 5.3.1.

5.2.4 Write Data Command Execution Time [4].
 (512 Byte Sector Size and without disconnect) Latency time is included.

a. From CDB reception to the request for the first byte of write data from the Host.

- 1. Typical 0.4 ms
- 2. Maximum 0.6 ms

b. Single Sector Write [7] [6]

(Measured from receipt of the last byte of the CDB to the request for a completion status transfer to the Host)

- 1. Typical (Zero Stroke Seek) 12.5 ms [3]
- 2. Typical (Average Seek) 27.5 ms [3]
- 3. Maximum (Full Stroke Seek) 60.5 ms [2]

5.3 GENERALIZED PERFORMANCE CHARACTERISTICS

See Section 5.3.1 for Notes.

Minimum Sector Interleave 1 to 1

Data Buffer To/From Disk Media Data
 Transfer Rate (≤ 1 sector) - 512 Byte Sector
 Min [4] 1.5 MByte/sec
 Avg [4] 1.82 MByte/sec
 Max [4] 2.0 MByte/sec

Data Buffer To/From Disk Media
 Data Transfer Rate (≤ 1 Track) - 512 Byte Sector
 Min. [4] 1.32 MByte/sec - (Interleave Factor)
 Avg. [4] 1.61 MByte/sec - (Interleave Factor)
 Max. [4] 1.77 MByte/sec - (Interleave Factor)

SCSI Interface Data
 Transfer Rate (Asynchronous) [5]

- Maximum Instantaneous 2.0 MBytes/sec
- Maximum Average 1.82 MBytes/sec

Sector Sizes 512 user data blocks (default)
 Variable (256 to 4096)

Transfer Rate (Synchronous)

From 1.0 MBytes/sec to 4.7 MBytes/sec
 in 23.8 to 25 KBytes/sec increments (See section 12.5.4.)

5.3 (continued)

Read/Write consecutive sectors on a track	YES
Flaw reallocation performance impact (For flaws reallocated at format time using the spare sectors per track reallocation scheme.)	Negligible (typically 1 sector time)
Flaw reallocation performance impact (For flaws reallocated at format time using the spare sectors per cylinder reallocation scheme.)	Min-1 sector time (If flaw on same track as spare) Normally - 17 ms Max - 34 ms
Flaw reallocation performance impact (For flaws reallocated at format time using the spare tracks per volume reallocation scheme.)	50 ms (typical)
Overhead time for head switch (512 byte sectors)	Less than 2 ms
Overhead time for one track cylinder switch	6 ms Typical
Avg rotational latency	8.33 ms

5.3.1 Notes for Sections 5.2 and 5.3.

- [1] Execution time measured from receipt of the last Byte of the Command Descriptor Block (CDB) to the request for a Status Byte Transfer to the Initiator (excluding connect/disconnect).
- [2] Maximum times are specified over the worst case conditions of temperature, voltage margins and drive orientation. When comparing specified seek times, care should be taken to distinguish between typical seek times and maximum seek times. The best comparison is obtained by system benchmark tests conducted under identical conditions.
- [3] Typical Seek values are measured under nominal conditions of temperature, voltage, and horizontal orientation as measured on a representative sample of WREN V drives.

5.3.1 Notes for Sections 5.2 and 5.3. (continued)

- [4] Assumes no errors and assumes the sector(s) has not been relocated.
- [5] Rate measured from the start of the first sector transfer with the Host.
- [6] Assumes the Initiator immediately begins sending Write Data to the WREN V when requested.
- [7] Command execution requires a data transfer phase (Data To/From the disk media). Assumes the initiator is instantly ready to send/receive the Data when the WREN V generates first request for a data byte transfer, and assumes an average data transfer rate between the WREN V and the Initiator of 1.25 Mbytes/second.

5.4 START/STOP TIME

After DC power has been applied, the WREN V will become ready within 39 seconds if the Motor Start Option is disabled (i.e. the motor starts as soon as the power has been applied). During this time the drive will respond to the SCSI interface. Stop time will be less than 30 seconds from removal of DC power.

If the Motor Start Option is enabled the internal controller will accept a Motor Start, Inquiry or Request Sense Command via the SCSI interface 3 seconds after DC power has been applied. After the Motor Start Command has been received the WREN V will become ready for normal operations within 36 seconds. During this time the drive will respond to the SCSI interface in accordance with the rules described in paragraph 13.1.4 for Command Queing.

There is no power control switch on the drive.

5.5 READ LOOK-AHEAD/CACHE CONTROL

The WREN V Model 94181 provides a Read Look-ahead buffering algorithm which can in many cases enhance system performance. This feature may be selected by issuing a Mode Select Command with the Enable/Disable Cache bit set in the Cache Control page (see para. 14.2.1.7 and 10).

The following is a simplified description of the Read Look-ahead operation:

Case A - Read command received and first LBA not in cache

1. Fetch requested data from disk and transfer to host.
2. Fetch remaining logical blocks on current track and save in cache.

Case B - Read command received and first LBA already in cache

1. Start transfer to (host) of all logical blocks requested which are already in cache.
2. Fetch (from disk) requested logical blocks which are not already in cache and queue for transfer to host.
3. Fetch remaining logical blocks on current track and save in cache.

In both cases the caching operation will abort if a new command is received, unless the command matches case B above.

Read Look-ahead is particularly important when optimizing performance in systems which transfer large blocks of sequential data using multiple read commands. In this situation Read Look-ahead will allow a 1 to 1 interleave without slipped revolutions between reads.

6.0 RELIABILITY SPECIFICATIONS

The following reliability specifications assume correct host/drive operational interface, including all interface timings, power supply voltages, and environmental requirements.

Seek Errors	Less than 1 in 10 ⁶ seeks
Read Error Rates [1]	
Unrecovered Data	Less than 1 sector in 10 ¹⁴ bits transferred
Miscorrected Data	Less than 1 sector in 10 ²¹ bits transferred
MTBF	40,000 hours
Service Life	5 years
Preventive Maintenance	None required

NOTES: [1] Error rate specified with automatic retries and data correction via ECC enabled and all flaws reallocated.

6.1 ERROR RATES

The error rates stated in this specification assume the following:

- a. WREN V is operated per this specification using DC Power as defined in this specification (see Section 7.2).
- b. The WREN V has been formatted via the SCSI FORMAT commands.
- c. Errors caused by media defects or host system failures are excluded from error rate computations. Refer to Paragraph 8.0, Media Characteristics.

6.1.1 Read Errors

Before determination or measurement of read error rates:

- a. The data which is to be used for a measurement of read error rates must be verified as being written correctly on the media.
- b. All media defect induced errors must be excluded from error rate calculations.

6.1.2 Environmental Interference

When evaluating systems operation under conditions of Electromagnetic Interference (EMI), the performance of the WREN V within the system shall be considered acceptable if the WREN V does not generate an unrecoverable condition.

An unrecoverable error, or condition, is defined as one which:

1. Is not detected and corrected by the WREN V itself;
2. Is not capable of being detected from the error or fault status provided through the WREN V/system interface; or
3. Is not capable of being recovered by normal WREN V or system recovery procedures without operator intervention.

6.1.3 Write Errors

Write errors can occur as a result of: media defects, environmental interference, or equipment malfunction. Therefore, write errors are not predictable as a function of the number of bits passed.

If an unrecoverable write error occurs because of an equipment malfunction in the WREN V, the error is classified as a failure affecting MTBF. Unrecoverable write errors are those which cannot be corrected within two attempts at writing the record with a read verify after each attempt, (excluding media defects).

6.1.4 Seek Errors

A seek error is defined as a failure of the WREN V to position the heads to the addressed track. There shall be no more than one recoverable seek error in 10^6 physical seek operations. A recoverable seek error (with the WREN V automatic retry feature disabled) is a positioning error which can be corrected by the host issuing a Rezero Unit command and then reseeking to the addressed track. If automatic retry control is enabled in the drive, it will automatically retry a Rezero Unit and reseek to the addressed track up to 3 times. If a seek is successful, the Extended Sense will report a seek positioning error (15H) and the sense key will report a recovered error (1H). If all three seeks fail a seek positioning error (15H) will be reported with a Medium (3H) or Hardware error (4H) reported in the Sense Key. This is an unrecoverable seek error. Unrecoverable seek errors are classified as failures for MTBF calculations.

6.2 RELIABILITY AND SERVICE

6.2.1 Mean Time Between Failure

The Mean Time Between Failure (MTBF) shall exceed 40,000 hours for the WREN V. MTBF is defined as "operating drive-hours" divided by the "number of drive failures".

"Operating drive-hours" means total power on hours of a sample* number of drives less any time when the sample* drives are not functioning properly times the number of drives in the sample* used in the MTBF calculation. "Drive failure" means any stoppage or substandard performance of the drive because of drive malfunction, excluding stoppages or substandard performance caused by operator error, adverse environment, power failure, host adapter (or other initiator) failure, cable failure, or other failure not caused by the drive.

The term drive failure implies that maintenance is required because of a hardware failure. However, only random failures are considered -- not normal wear-out failures.

6.2.2 Preventive Maintenance

No routine scheduled preventive maintenance shall be required.

6.2.3 Service Life

The WREN V shall have a useful service life of five years before requiring factory refurbishment. Depot repair or replacement of major parts will be permitted during the lifetime (6.2.4).

6.2.4 Service Philosophy

Special equipment is required to repair the WREN V HDA. In order to achieve the above service life, repairs must be performed only at a properly equipped and staffed service and repair facility. Troubleshooting and repair of PWAs in the field is not recommended, because of the extensive diagnostic equipment required for effective servicing.

6.2.5 Installation

The WREN V is designed, manufactured, and tested with a "Plug in and Play" installation philosophy. This philosophy minimizes the requirements for highly trained personnel to integrate the WREN V into the OEM's system, whether in a factory or field environment.

*Sample size must be chosen in accordance with generally recognized statistics rules in order to adequately represent the total drive population.

6.2.6 Service Tools

No special tools are required for site installation or recommended for site maintenance. Refer to Paragraph 6.2.4. The depot repair philosophy of WREN V precludes the necessity for special tools. If field repair of items external to the HDA is desired, a 6 point Torx T10 driver is required. This may be purchased through most commercial tool catalogs.

7.0 PHYSICAL/ELECTRICAL SPECIFICATIONS

7.1 AC POWER REQUIREMENTS

None

7.2 DC POWER REQUIREMENTS

The voltage and current requirements for a single WREN V are shown in the following table. Values indicated apply at the drive power connector.

TABLE 7.2-1. DC POWER REQUIREMENTS

Voltage	+5 V	+12 V
Regulation	±5%	±5% [2]
Noise Immunity [3]	100 mV	100 mV
Maximum Operating Current [1]	0.9 A	2.2 A
Average Idle Current [1] [4]	0.7 A	1.6 A
Maximum Starting Current (Peak)	1.0 A	4.5 A
Delayed Motor Start (Max) [5]	1.0 A	0.9 A

[1] Measured with average reading DC ammeter.

[2] A ±10% tolerance is permissible during power up. The ±5% must be maintained after the drive signifies that its power up sequence has been completed and that the drive is able to accept selection by the Host Initiator.

[3] Noise is specified as periodic and random distribution of frequencies covering a band from DC to 10 MHz. Values given are peak to peak measurements

[4] See +12 V current profile level T6 in Figure 7.2.2-1.

[5] This condition occurs when the Motor Start Option is enabled and the drive has not yet received a Start Motor command.

General Notes for Table 7.2-1:

1. At powerup, the motor current regulator will limit the 12 volt current to a peak value of less than 4.5 amperes.
2. Minimum current loading for each supply voltage is not less than 30% of the maximum operating current shown.
3. The +5 and +12 volt supplies shall employ separate ground returns.
4. Where power is provided to multiple drives from a common supply, careful consideration for individual drive power requirements should be noted. Where multiple units are powered on simultaneously, the peak starting current must be available to each device. (Ref. Table 1).

7.2.1 Power Sequencing

Power sequencing is not required for the WREN V. The WREN V protects against inadvertent writing during power up and down. Daisychain operation requires that power be maintained on the terminated WREN V to ensure proper termination of the peripheral I/O cables.

7.2.2 12 V - Current Profile

Figure 7.2.2-1 identifies the WREN V 12 V current profile. The current during the various times is as shown:

- T1 - Power is initially applied to the WREN V and the spindle begins to accelerate under current limiting.
- T2 - The spindle continues to accelerate under current limiting conditions.
- T3 - The spindle is up to speed and the heads are moved from the landing zone to the data area.
- T4 - The autovelocity adjust sequence and controller self test is performed.
- T5 - Velocity is set and the WREN V is ready for reading and writing.
- T6 - Power is removed from the WREN V.

NOTE

All times and currents are typical. See Table 7.2-1 for maximum current requirements.

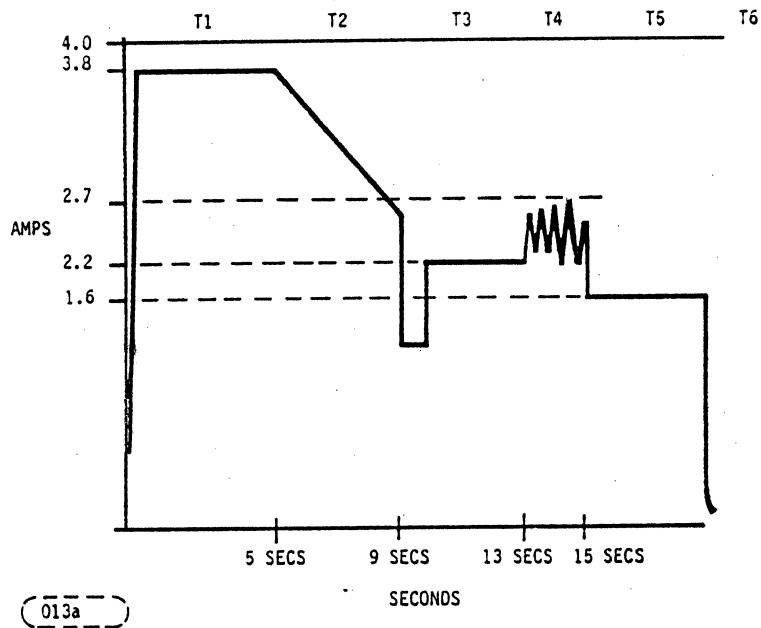

FIGURE 7.2.2-1. TYPICAL WREN V +12 V CURRENT PROFILE

7.3 HEAT/POWER DISSIPATION

Each WREN V will dissipate no more than 27 watts (92 BTUs per hour) of DC power average under worst case operating conditions. Typical power dissipation under idle operating conditions is less than 21 watts.

7.4 ENVIRONMENTAL LIMITS

Temperatures and humidity specifications preclude condensation on any WREN V part. Altitude and atmospheric pressure specifications are referenced to a standard day at 58.7°F (14.8°C). Maximum Wet Bulb temperature is 82°F (28°C).

7.4.1 Temperature

a. Operating

50°F to 122°F (10°C to 50°C) operating ambient with a maximum gradient of 36°F (20°C) per hour. The maximum temperature is derated linearly 1.8°F per 1640 ft. (1°C per 500 metres). Cabinet packaging designs must provide ample air circulation around the WREN V to ensure environmental limits are not exceeded as a result of heat transfer from other system components. Operating ambient is defined as the average temperature 0.25 inch outward from the top of the drive chassis at the middle of the drive (lengthwise). The temperature of the top cover must not exceed 140°F (60°C) when measured at the center of the drive.

b. Transit

-40° to 158°F (-40° to 70°C) package ambient with a maximum gradient of 45°F (25°C) per hour. This specification assumes that the WREN V is packaged in the shipping container designed by CDC for use with WREN V.

c. Storage

14° to 130°F (-10° to 54°C) device ambient with a maximum gradient of 27°F (15°C) per hour.

7.4.2 Relative Humidity

- a. Operating
8% to 80% relative humidity with a maximum gradient of 10% per hour.
- b. Transit
5% to 95% relative humidity.
- c. Storage
8% to 90% relative humidity.

7.4.3 Effective Altitude (Sea Level Reference)

- a. Operating
-1000 to +10,000 feet (-305 to +3048 metres)
- b. Transit
-1000 to +40,000 feet (-305 to +12,210 metres)
- c. Storage
-1000 to +10,000 feet (-305 to +3048 metres)

7.4.4 Shock and Vibration

Shock and vibration limits specified in this document are measured directly on the WREN V chassis. If the WREN V is installed in an enclosure to which the stated shock and/or vibration criteria is applied, resonances may occur internally to the enclosure resulting in WREN V movement in excess of the stated limits. If this situation is apparent, it may be necessary to modify the enclosure to minimize WREN V movement.

The limits of shock and vibration defined within this document are specified with the WREN V mounted by any of the four methods shown in Figure 7.4-1. Orientation of the side nearest the LED may be up or down, though the figure shows it down.

7.4.4.1 Shock

a. Operating - Normal

Equipment, as installed for normal operation, shall comply with the complete specified performance while subjected to intermittent shock not exceeding 2 g at a maximum duration of 10 ms (half sinewave). Shock may be applied in the X, Y, or Z axis. Shock is not to be repeated more than two times per second.

b. Operating - Abnormal

Equipment, as installed for normal operation, shall not incur physical damage while subjected to intermittent shock not exceeding 10 g at a maximum duration of 10 ms (half sinewave). Shock occurring at abnormal levels may promote degraded operational performance during the abnormal shock period. Specified operational performance will continue when normal operating shock levels resume. Shock may be applied in the X, Y, or Z axis. Shock is not to be repeated more than two times per second.

c. Nonoperating

The limits of nonoperating shock shall apply to all conditions of handling and transportation. This includes both isolated devices and integrated equipment.

Equipment subjected to nonrepetitive shock not exceeding 32 g at a maximum duration of 10 ms (half sinewave) shall not exhibit device damage or performance degradation. Shock may be applied in the X, Y, or Z axis.

d. Packaged

The WREN V as packaged by CDC for general freight shipment shall withstand drop test from 42 inches (1070 mm) against a concrete floor or equivalent.

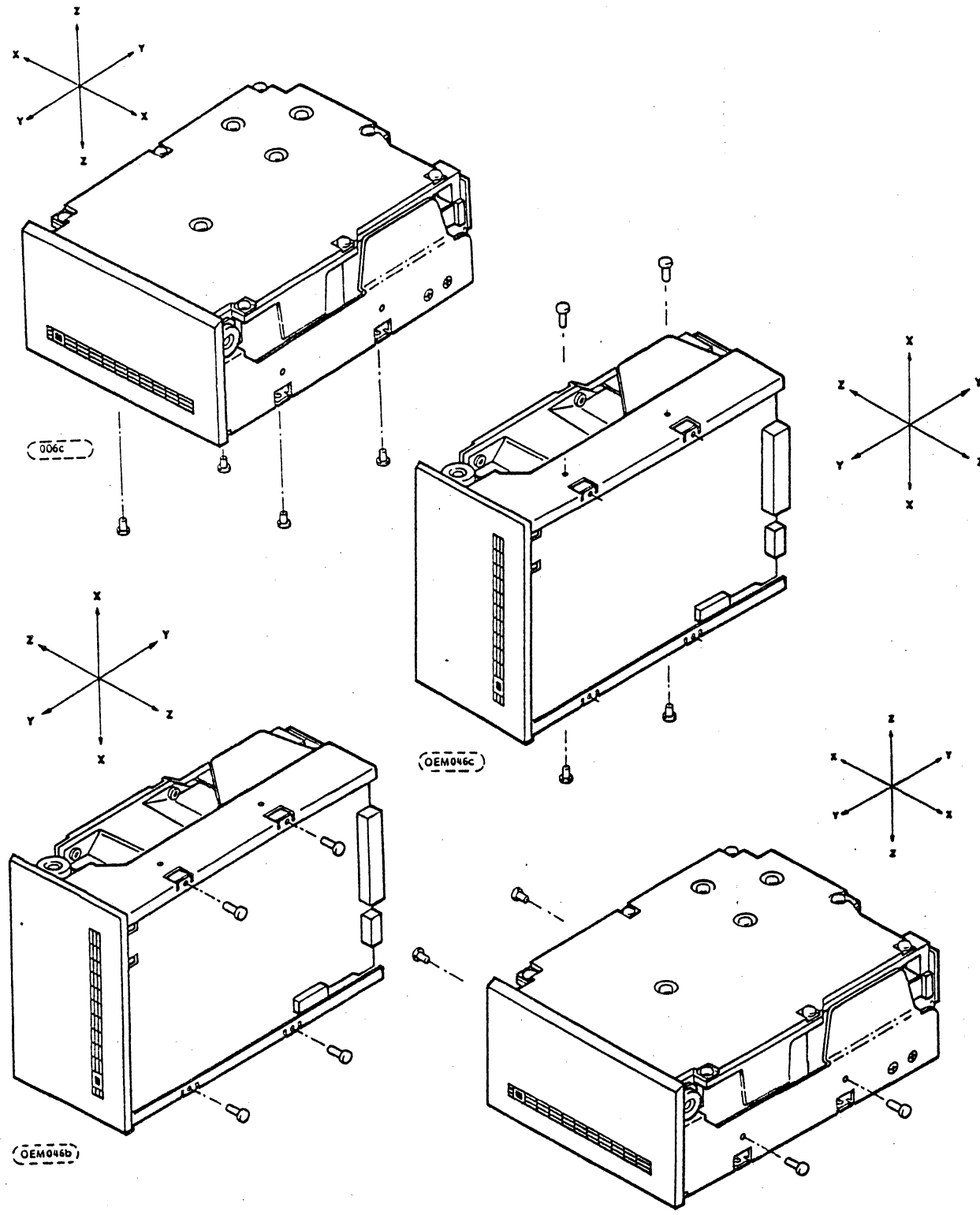

FIGURE 7.4-1. RECOMMENDED MOUNTING

7.4.4.2 Vibration

- a. Operating - Normal
Equipment as installed for normal operation, shall comply with the complete specified performance while subjected to continuous vibration not exceeding
5-22 Hz @ 0.010 inches (0.25 mm) displacement
22-500 Hz @ 0.5 g
Vibration may be applied in the X, Y, or Z axis.
- b. Operating - Abnormal
Equipment as installed for normal operation, shall not incur physical damage while subjected to periodic vibration not exceeding
15 minutes of duration at major resonant frequency
5-22 Hz @ 0.020 inches (.51 mm) displacement
22-500 Hz @ 0.75 g
Vibration occurring at these levels may promote degraded operational performance during the abnormal vibration period. Specified operational performance will continue when normal operating vibration levels are resumed. This assumes system recovery routines are available. Abnormal vibration may be applied in the X, Y, or Z axis.
- c. Nonoperating
The limits of nonoperating vibration shall apply to all conditions of handling and transportation. This includes both isolated devices and integrated equipment.

Equipment shall not incur physical damage or degraded performance as a result of continuous vibration not exceeding
5-22 Hz @ 0.040 inches (1.02 mm) displacement
22-500 Hz @ 1.00 g
Vibration may be applied in the X, Y, or Z axis.

7.4.5 Air Cleanliness

The WREN V is designed to operate in a typical office environment with minimal environmental control.

7.5 ELECTROMAGNETIC COMPATIBILITY

7.5.1 Electromagnetic Susceptibility

As a component assembly, the WREN V is not required to meet any susceptibility performance requirements. It is the responsibility of the system integrator to perform those tests required to assure that equipment operating in the same system as the WREN V does not adversely affect the performance of the WREN V. See section 6.1.2, and see Table 7.2-1, DC Power Requirements.

7.6 ACOUSTIC NOISE LEVEL

Acoustic noise power level of the WREN V should be less than 5.2/5.7 (four sides) bels during idle/operating mode. Equivalent typical average sound pressure level should be less than 47/51 dba when measured with microphone at a distance of one metre from the drive.

7.7 MECHANICAL SPECIFICATIONS

The following nominal dimensions are exclusive of the decorative front panel accessory. Refer to Figure 7.7-1 for detailed mounting configuration dimensions.

Height: 3.25 in 82.55 mm
 Width: 5.75 in 146.05 mm
 Depth: 8.0 in 203.2 mm
 Weight: 7.6 pounds 3.4 kilograms

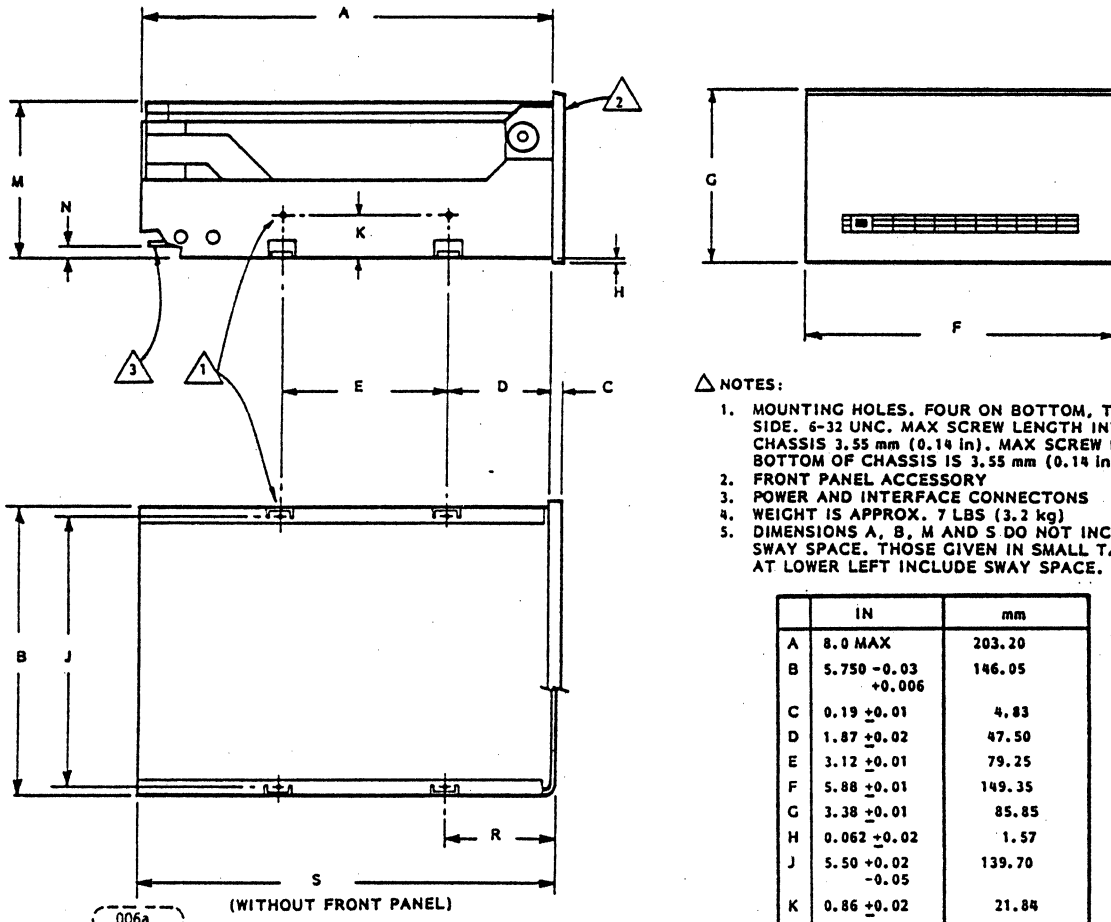

- △ NOTES:
1. MOUNTING HOLES. FOUR ON BOTTOM, TWO ON EACH SIDE. 6-32 UNC. MAX SCREW LENGTH INTO SIDE OF CHASSIS 3.55 mm (0.14 in). MAX SCREW LENGTH INTO BOTTOM OF CHASSIS IS 3.55 mm (0.14 in).
 2. FRONT PANEL ACCESSORY
 3. POWER AND INTERFACE CONNECTONS
 4. WEIGHT IS APPROX. 7 LBS (3.2 kg)
 5. DIMENSIONS A, B, M AND S DO NOT INCLUDE SWAY SPACE. THOSE GIVEN IN SMALL TABLE AT LOWER LEFT INCLUDE SWAY SPACE.

	IN	mm
A	8.0 MAX	203.20
B	5.750 ± 0.03 $+0.006$	146.05
C	0.19 ± 0.01	4.83
D	1.87 ± 0.02	47.50
E	3.12 ± 0.01	79.25
F	5.88 ± 0.01	149.35
G	3.38 ± 0.01	85.85
H	0.062 ± 0.02	1.57
J	5.50 ± 0.02 -0.05	139.70
K	0.86 ± 0.02	21.84
M	3.25 ± 0.035	82.55
N	0.33 REF	8.38 REF
R	1.93 ± 0.01	49.02
S	8.06 MAX	204.7

INCLUDING SWAY SPACE

	IN.	mm	
A	8.08 MIN	205.23 MIN	
B	SIDE MOUNTED BOTTOM MOUNTED	5.75 MIN 5.90 MIN	146.05 MIN 149.86 MIN
M	3.33 MIN	84.58 MIN	
S	8.14 MIN	206.76 MIN	

FIGURE 7.7-1. MOUNTING CONFIGURATION DIMENSIONS

7.7.1 Drive Orientation

Only two WREN V mounting orientations are permitted: disks in the horizontal plane and disks in the vertical plane. The uppermost surface must be maintained in a level position or WREN V performance may be adversely affected. Mounting with either end down (front or rear) is not permissible. In the horizontal orientation, the spindle axis must be vertical with the disks on top.

7.7.2 Cooling

Cabinet cooling must be designed by the customer so that the ambient temperature immediately surrounding the WREN V will not exceed temperature conditions specified in 7.4.1. Specific consideration should be given to make sure adequate air circulation is present around the PWAs at the rear of the drive.

8.0 MEDIA CHARACTERISTICS

8.1 MEDIA DESCRIPTION

The media used on the WREN V has a diameter of approximately 5 1/4 inches (130 mm). The aluminum substrate is coated with a thin film magnetic material, overcoated with a proprietary protective layer for improved durability and environmental protection.

9.0 DEFECT AND ERROR MANAGEMENT

WREN V, as delivered, complies with this specification. The read error rate and specified storage capacity are not dependent upon use of defect management routines by the host (initiator).

Defect and error management in the SCSI system involves WREN V internal defect/error management and SCSI systems error considerations (errors in communications between Initiator and WREN V). Tools for use in designing a defect/error management plan are briefly outlined in this section, with references to other sections where further details are given.

9.1 WREN V INTERNAL DEFECTS/ERRORS

Identified defects are recorded on the WREN V defects list tracks (referred to as the primary or ETF defect list). It is recommended that these known defects be reallocated during the initial WREN V format operation. (See Format Unit command in Section 14.2.1.1.) The WREN V internal retries and data correction by ECC should be enabled to recover data from additional flaws if they occur. If data correction by ECC is required to recover data, the host should immediately reallocate this sector by use of the Reassign Blocks command. (See Section 14.2.1.3.) If the WREN V automatic retries and data correction by ECC features are not used, defects are usually unrecoverable and need to be reallocated as they are discovered. For reallocation of bad sectors, the number of spare sectors per track or cylinder and the number of spare tracks per volume is programmable. After formatting, defects can be automatically reallocated by the WREN V, or can be reallocated when the host sends the Reassign Blocks Command (Section 14.2.1.3).

Once the necessary details are described about the operation of the interface (Sections 10 thru 14), more information on the WREN V Error Recovery philosophy is presented in Section 16.0.

9.2 SCSI SYSTEMS ERROR CONSIDERATIONS

Information on the reporting of operational errors or faults across the interface is given in Sections 12.5.2, 14.1.1, and 15.0. Section 12.5.2 of this specification describe the Message Protocol System. Several of the messages are used in the SCSI systems error management system. The Request Sense command returns information to the host about numerous kinds of errors or faults. The Receive Diagnostic Results reports the results of diagnostic operations performed by the WREN V.

Section 15.0 describes the status returned by the WREN V to the Initiator. Status reporting plays a role in the SCSI systems error management and its use in that respect is described in sections where the various commands are discussed.

10.0 INTERFACE REQUIREMENTS AND OPTIONS

10.1 GENERAL DESCRIPTION

This specification describes the Magnetic Peripherals Inc. subset of the SCSI (Small Computer Systems Interface) as implemented on the WREN V. The interface is compatible with the mandatory subset of the CDC SCSI Interface Specification (both are compatible with the ANSI SCSI standard and the common command set (CCS) document, Revision 4.B). The WREN V Model 94181 is classified as an "Intelligent" peripheral.

The Model 94181 WREN V SCSI interface consists of a 9 bit bidirectional bus (8 data + 1 parity) plus 9 control signals supporting multiple initiators, command queuing of up to one command per initiator, disconnect/reconnect, self configuring host software and automatic features that relieve the host from the necessity of knowing the physical architecture of the target (logical block addressing is used).

The physical interface consists of single ended drivers and receivers using asynchronous or synchronous communication protocols which support cable lengths of up to 6 metres and a bus interface transfer rate up to 2.0 MB/s asynchronous 4.7 MBytes/sec synchronous. The bus protocol supports multiple initiators, disconnect/reconnect, additional messages plus 6 byte and 10 byte Command Descriptor Blocks. The WREN V is always a target on the SCSI. For purposes of this specification, "WREN V" may be substituted for the word "target" wherever "target" appears.

GLOSSARY

Byte - This term indicates an 8 bit (octet) byte.

Command Descriptor Block (CBD) - The structure used to communicate requests from an initiator to a target.

Connect - The function that occurs when an initiator selects a target to start an operation.

Disconnect - The function that occurs when a target releases control of the SCSI bus, allowing it to go to the Bus Free phase.

10.1 (continued)

FRU (Field Replaceable Unit) - An assembly that is believed faulty based on test results. A value of OOH indicates an unknown cause or the end of a list of known possible causes. Nonzero values have product unique meanings.

Initiator - A SCSI device (usually a host system) that requests an operation to be performed by another SCSI device.

Intermediate Status - A status code sent from a target to an initiator upon completion of each command, except the last command, in a set of linked commands.

Logical Unit - A physical or virtual device addressable through a target.

Logical Unit Number - An encoded three bit identifier for the logical unit.

LSB - Least significant byte.

LUN - Logical unit number.

mm - Millimetre.

ms - millisecond.

MSB - Most significant byte.

ns - Nanosecond.

One - A true signal value, (assertion).

Reconnect - The function that occurs when a target selects and initiator to continue an operation after a disconnect.

Reserved - The term used for bits, bytes, fields, and code values that are set aside for future standardization.

SCSI Address - The octal representation of the unique address (0-7) assigned to a SCSI device. This address would normally be assigned and set in the SCSI device during system installation (see Figure 11.1-1).

SCSI ID - The bit significant representation of the SCSI address referring to one of the signal lines DB(7-0).

10.1 (continued)

SCSI device - A host computer adapter or a peripheral controller or an intelligent peripheral that can be attached to the SCSI bus.

Signal Assertion - The act of driving a signal to the true state.

Signal Negation - The act of driving a signal to the false state or allowing the cable terminators to bias the signal to the false state (by placing the driver in the high impedance condition).

Signal Release - The act of allowing the cable terminators to bias the signal to the false state (by placing the driver in the high impedance condition).

Status - One byte of information sent from a target to an initiator upon completion of each command.

Target - A SCSI device that performs an operation requested by an initiator.

us - Microsecond.

Vendor Unique - In this specification, this term indicates bits, fields, or code values that are vendor specific.

xxH - Numbers followed by capital H are hexadecimal values. All other numbers are decimal values.

Zero - A false signal value, (negation).

10.2 DC CABLE AND CONNECTOR

The WREN V receives DC power through a 4 pin right angle connector (see Table 10.2-1 for pin assignment) mounted on the servo PWA (see Figure 10.3-3). Recommended part numbers of the mating connector are listed below, but equivalent parts may be used (see Table 10.2-2.).

TABLE 10.2-1. DC INTERFACE

<u>POWER LINE DESIGNATION</u>	<u>PIN NUMBER</u>
+12 V	J1-01
+12 V Return	J1-02
+ 5 V Return	J1-03
+ 5 V	J1-04

TABLE 10.2-2. MATING CONNECTOR PARTS

<u>TYPE OF CABLE</u>	<u>CONNECTOR</u>	<u>CONTACTS (20-14 AWG)</u>
14 AWG	AMP 1-480424-0	AMP 60619-4 (Loose Piece) AMP 61117-4 (Strip)

10.3 PHYSICAL CHARACTERISTICS

This section defines the connectors, cables, signals, terminators and bus timing needed to implement SCSI.

10.3.1 Physical Description

Model 94181 WREN V may be daisy chained together or with other compatible SCSI devices using a common cable. Both ends of the cable must be terminated. The WREN V implements single ended drivers and receivers, which allow a maximum cable length of six metres (primarily for connection within a cabinet). All signals are common between all SCSI devices. The Model 94181 WREN V may be daisy chained only with SCSI devices with single ended drivers and receivers. A maximum of 8 SCSI devices (including the Host) may be daisy chained together. The SCSI Devices at both ends of the daisy chain are to be terminated. Intermediate SCSI devices shall not be terminated. (see Figure 10.3-2). Remove the terminator resistor packs, not the terminator power source selector jumper (Figure 10.3-3).

10.3.2 Cable Requirements

Only nonshielded cable connectors are applicable. A 50 conductor flat cable or 25 twisted pair cable shall be used. The maximum total cable length shall be 6.0 metres. A stub length of no more than 0.1 metre is allowed off the mainline interconnection within any connected equipment. An ideal impedance match with cable terminators implies a cable characteristic impedance of 132 ohm (singled ended option). In general, cables with this high of a characteristic impedance are not available; however, impedances that are somewhat lower are satisfactory. A characteristic impedance of 100 ohm \pm 10% is recommended for unshielded flat or twisted pair ribbon cable. However, most available cables have a somewhat lower characteristic impedance. To minimize discontinuities and signal reflections, cables of different impedances should not be used in the same bus. Implementations may require trade-offs in shielding effectiveness, cable length, the number of loads, transfer rates, and cost to achieve satisfactory system operation. If shielded and unshielded cables are mixed within the same SCSI bus, the effect of impedance mismatch must be carefully considered.

A minimum conductor size of 28 AWG should be used to minimize noise effects.

Suggested nonshielded flat cable part numbers are:

Flat cable	3M-3365-50
Twisted pair	Spectra twist in flat 455-248-50

Equivalent parts may be used.

Single ended cable pin assignments are shown in Table 10.3-1.

10.3.3 Connectors Requirements

The nonshielded cable connector shall be a 50 conductor connector consisting of two rows of 25 female contacts with adjacent contacts 100 mils apart.

Recommended Mating Flat Cable Connector Part Numbers are:

Closed end (for cable ends) *	3M-3425-7000	W/O Strain Relief, No Center Key
	3M-3425-7050	With Strain Relief, No Center Key
	Dupont-66900-290	With Strain Relief, With Center Key
Open end (In Daisychain)	3M-3425-6000	W/O Strain Relief, No Center Key
	3M-3425-6050	With Strain Relief, No Center Key
	Dupont-66900-250	With Strain Relief, With Center Key

* See Figure 10.3-2.
(2443P)

10.3.3 continued

The Model 94181 WREN V device connector is a nonshielded 50 conductor connector consisting of two rows of 25 male pins with adjacent pins 100 mils apart. The connector is keyed (see Figure 10.3-1).

Drive Connector Part Number: Berg - 65496 - 031 or equivalent.

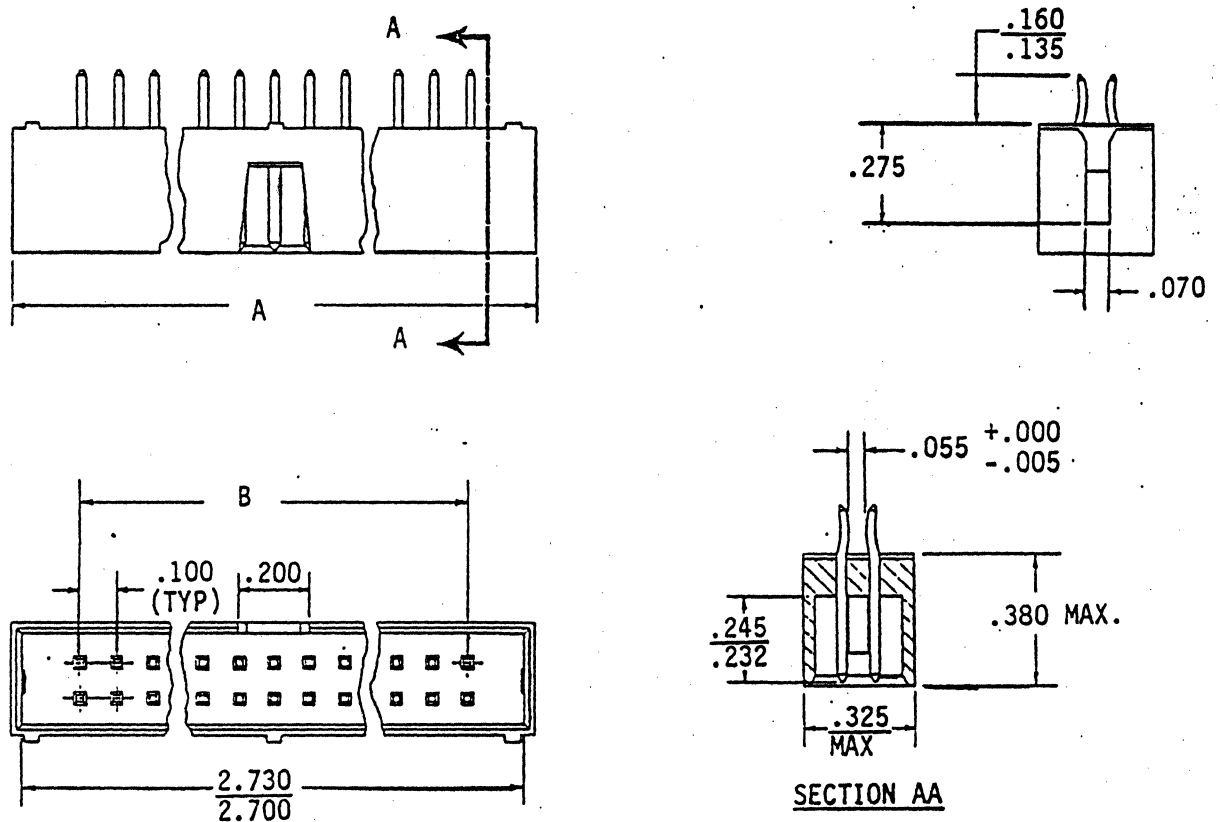

NOTES:

1. Fifty Contacts on 2.54 mm (0.100 inch) spacing = 60.96 mm (2.40 inches).
2. Tolerances ± 0.127 mm (0.005 inch) noncumulative.
3. Dimensions listed with asterisks (*) are shown for reference only.

FIGURE 10.3-1. NONSHIELDED SCSI DEVICE CONNECTOR

10.3.3 continued

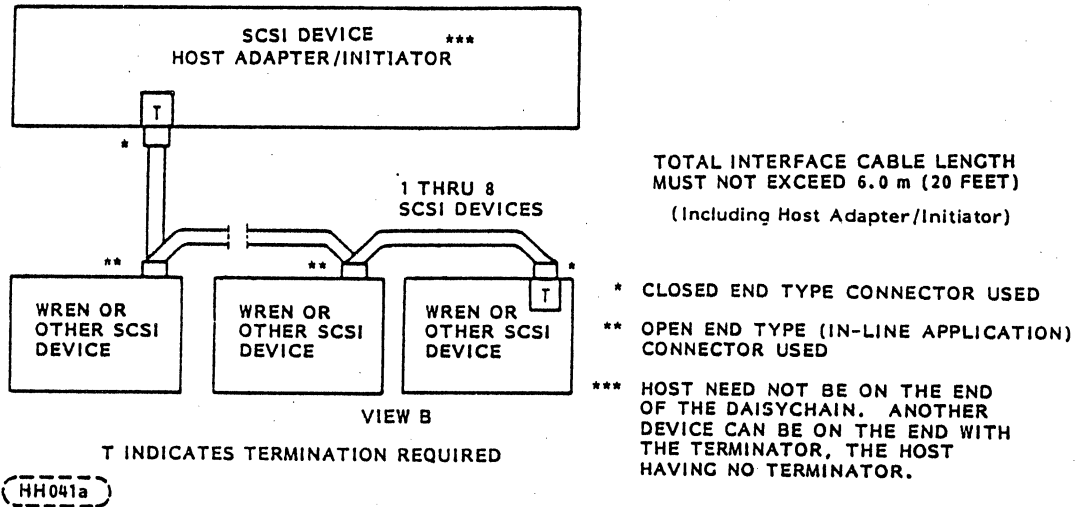

FIGURE 10.3-2. INTERFACE CABLING

TABLE 10.3-1. SINGLE ENDED CABLE PIN ASSIGNMENTS (NONSHIELDED CONNECTOR)

SIGNAL	PIN NUMBER	SIGNAL	PIN NUMBER
-DB(0)	2	GROUND	30
-DB(1)	4	-ATN	32
-DB(2)	6	GROUND	34
-DB(3)	8	-BSY	36
-DB(4)	10	-ACK	38
-DB(5)	12	-RST	40
-DB(6)	14	-MSG	42
-DB(7)	16	-SEL	44
-DB(P)	18	-C/D	46
GROUND	20	-REQ	48
GROUND	22	-I/O	50
GROUND	24		
TERMPWR	26		
GROUND	28		

NOTES: 1. All odd pins except pin 25 are connected to ground. Pin 25 is left open.

CAUTION

Pin 25 must not be connected to ground at the HOST end or the drive end of the cable. If the I/O connector should accidentally be plugged in upside down, terminator power on Pin 26 will be shorted to ground.

2. The minus sign next to the signals indicates asserted state is the low voltage of the two levels used for logic signals.

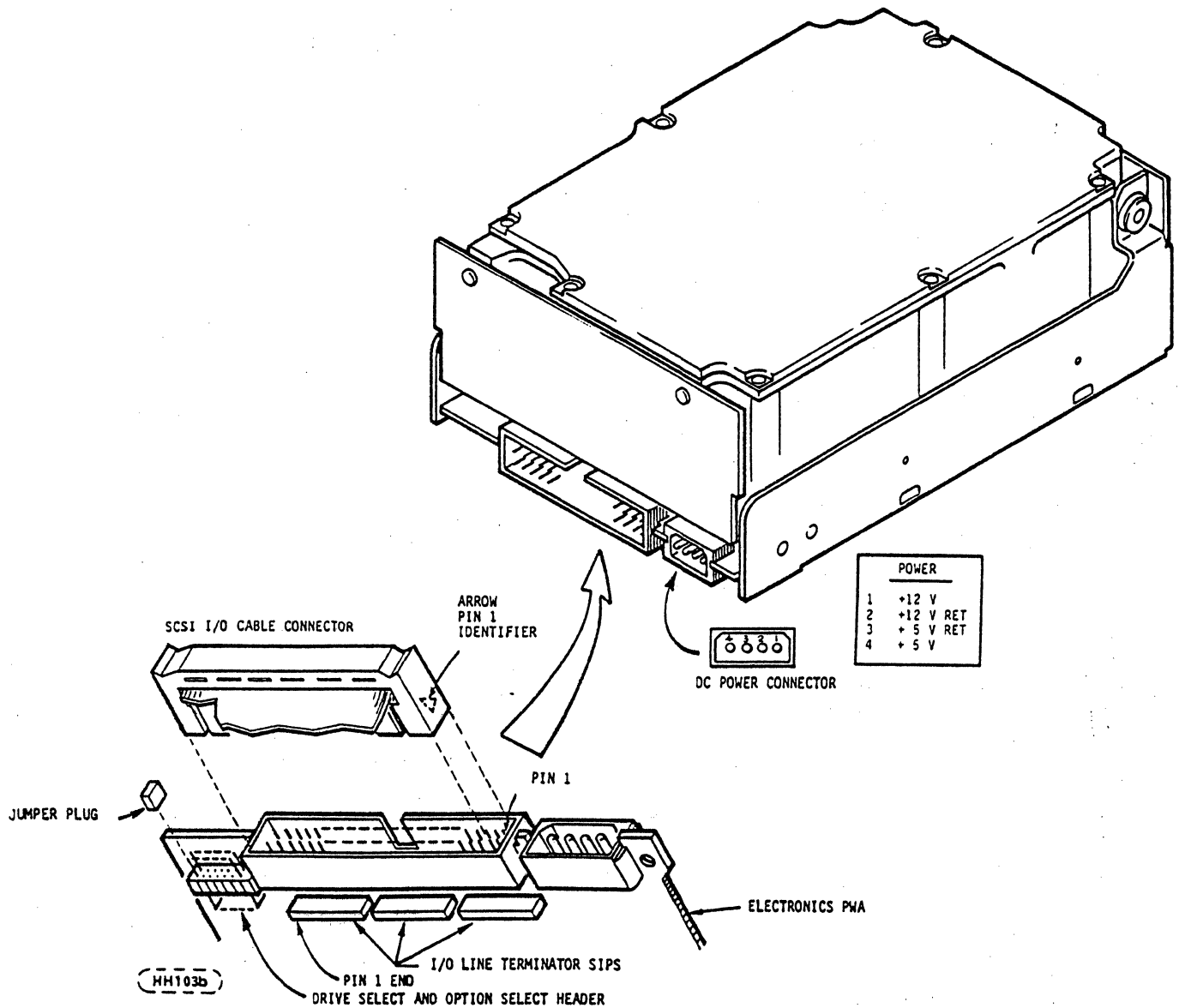

FIGURE 10.3-3. I/O CONNECTION

10.3.4 Electrical Description

All interface signals with the Model 94181 WREN V are single ended and must be terminated with 220 ohm to +5 V and 330 ohm to ground at each end of the total cable. All signals use open collector or three state drivers. Optional termination is available internal to the WREN V. See Figures 10.3-4 and 11.1-1.

10.3.4.1 Single Ended Drivers/Receivers

Single ended drivers and receivers are used by the WREN V. Typical circuits are shown in Figure 10.3-4. Terminator circuits shown are there only when the WREN V is last in the daisychain.

Transmitter Characteristics

The WREN V uses an ANSI SCSI compatible open collector single ended driver. This driver is capable of sinking a current of 48 mA with a low level output voltage of 0.4 volt.

Receiver Characteristics

The WREN V uses a ANSI SCSI single ended receiver with hysteresis gate or equivalent as a line receiver.

10.3.4.2 Terminator Requirements

Internal WREN V I/O termination consist of three resistor modules which plug into sockets on the Main PWA (see Figure 10.3-3). The WREN V may be ordered with or without these termination resistors to facilitate a particular application. All single initiator/single target (nondaisychain) applications require that the Initiator and WREN V be terminated. Daisychain applications require that only the units at each end of the daisychain be terminated. All other peripherals on the chain should not be terminated. (See Figure 10.3-2). NOTE: Remove terminator resistor packs where terminators are not required. Removal of terminator power source selection jumper* does not disconnect the terminator resistors from the circuit.

10.3.4.3 Terminator Power

The WREN V does not supply Terminator power for the SCSI bus. The WREN V may be configured to accept terminator power via Pin 26 of the SCSI bus or to provide terminator power for optional internal termination resistors via the WREN V power connector. See Figures 10.3-3 and 11.1-1.

Single ended SCSI devices providing termination power (TERMPWR) shall have the following characteristics:

V TERM = 4.0 V to 5.25 V
800 mA min source drive capability
1.0 mA maximum

*See Figure 11.1-1 for configuration details.

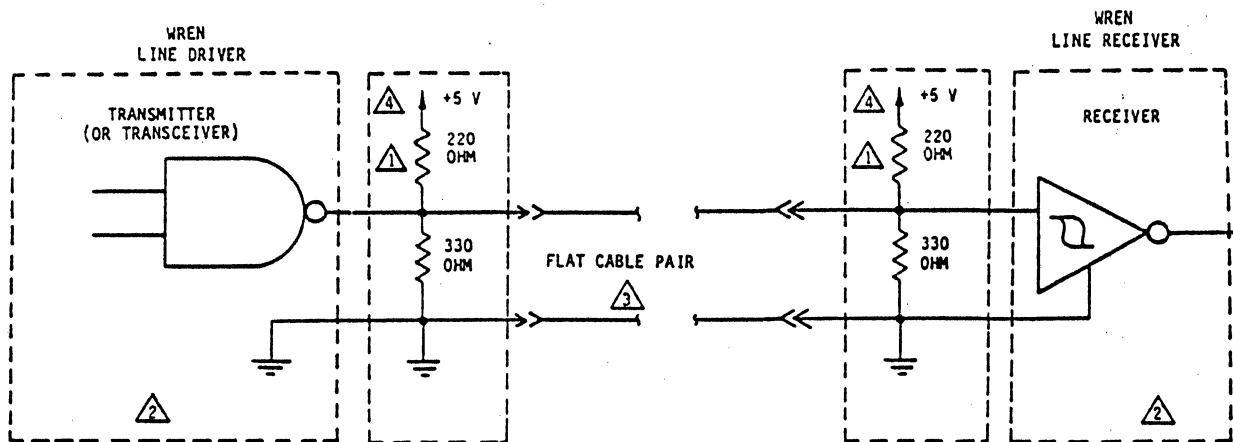

⚠ TERMINATOR CIRCUITS: PART OF REMOVABLE TERMINATOR RESISTOR PACKS, USED IN THE WREN V WHEN IT IS LAST IN THE DAISYCHAIN.

INTERFACE SIGNALS LEVELS AND LOGICAL SENSE AT THE WREN I/O CONNECTOR ARE DEFINED AS FOLLOWS:

LOGIC LEVEL		DRIVER OUTPUT	RECEIVER INPUT
NEGATED	(0)	$\geq 2.5 \text{ V}; \leq 5.25 \text{ V}$	$\geq 2.0 \text{ V}; \leq 5.25 \text{ V}$
ASSERTED	(1)	$\leq 0.4 \text{ V}; \geq 0.0 \text{ V}$	$\leq 0.8 \text{ V}; \geq 0.0 \text{ V}$

THE DIFFERENCE IN THE VOLTAGES BETWEEN INPUT AND OUTPUT SIGNALS IS DUE TO THE LOSSES IN THE CABLE.

⚠ ANSI SCSI COMPATIBLE CIRCUITS

⚠ TOTAL INTERFACE CABLE LENGTH SHOULD NOT EXCEED 20 FEET (6.0 m) FROM HOST TO END OF DAISYCHAIN.

⚠ SOURCE OF DRIVE TERMINATOR POWER SELECTABLE BY JUMPER PLUG.

(HH029b)

FIGURE 10.3-4. SINGLE ENDED TRANSMITTERS AND RECEIVERS

11.0 SCSI BUS

Communication on the SCSI Bus is allowed between only two SCSI devices at a time. There can be a maximum of eight SCSI devices including the host computer(s) connected to the SCSI bus. Each SCSI device has a SCSI ID Bit assigned as shown in Figure 11.0-1. The SCSI ID is assigned by installing from 0 to 3 jumper plugs onto a connector in a binary coded configuration during system configuration. See Figure 11.1-1.

When two SCSI devices communicate on the SCSI Bus one acts as an initiator and the other acts as a target. The initiator (typically a host computer) originates an operation and the target performs the operation. The WREN V always operates as a target.

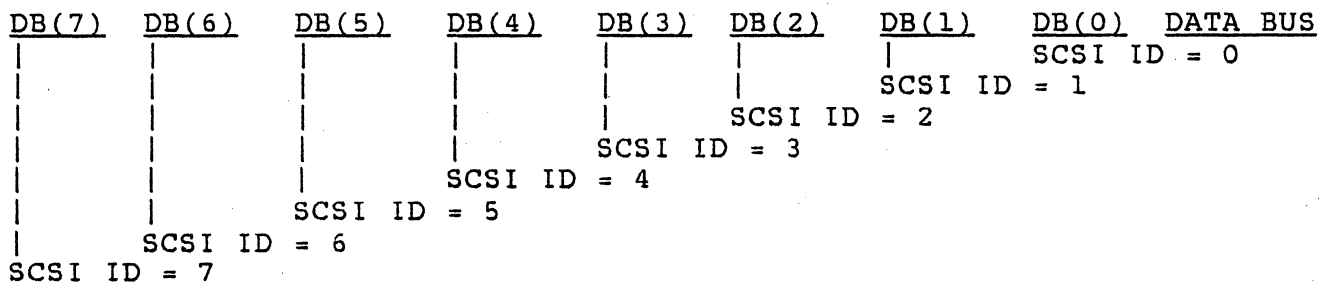

The Host Adapter/Initiator must be identified by one of the eight SCSI Device Addresses. Make sure that none of the devices on the interface have the same address as the HOST.

FIGURE 11.0-1. SCSI ID BITS

Certain SCSI bus functions are assigned to the initiator and certain SCSI bus functions are assigned to the target. The initiator will select a particular target. The target will request the transfer of Command, Data, Status or other information on the data bus.

Information transfers on the data bus are asynchronous and follow a defined REQ/ACK Handshake protocol. One byte of information will be transferred with each handshake. Synchronous data transfer option is described in Paragraph 12.5.4.

The WREN V supports single initiator, single target; single initiator, multiple target; or multiple initiator, multiple target bus configurations.

11.1 SCSI BUS SIGNALS

There are nine control and nine data signals, as listed below:

- BSY
- SEL
- C/D
- I/O
- MSG
- REQ
- ACK
- ATN
- RST
- DB(7-0, P)

These signals are described as follows:

BSY (BUSY) - An "OR-tied" signal to indicate the bus is being used.

SEL (SELECT) - A signal used by an initiator to select a target, or by a target to reselect an initiator.

C/D (CONTROL/DATA) - A signal driven by a target to indicate whether Control or Data information is on the Data Bus. Assertion (see Paragraph 11.1.1) indicates Control.

I/O (INPUT/OUTPUT) - A signal driven by a target to control the direction of data movement on the Data Bus with respect to an initiator. Assertion indicates input to the initiator. This signal is also used to distinguish between Selection and Reselection phases.

MSG (MESSAGE) - A signal driven by a target during the Message phase.

REQ (REQUEST) - A signal driven by a target to indicate a request for REQ/ACK data transfer handshake.

ACK (ACKNOWLEDGE) - A signal driven by an initiator to indicate an acknowledgment for a REQ/ACK data transfer handshake.

ATN (ATTENTION) - A signal driven by an initiator to indicate the Attention condition. It is used to request to send a message out to the target. See paragraph 12.2.1.

RST (RESET) - An "OR-tied" signal that indicates the Reset condition.

DB(7-0,P) (DATA BUS). Eight data bit signals, plus a parity bit signal form a Data Bus. DB(7) is the most significant bit and has the highest priority during the Arbitration phase. Bit number significance, and priority decrease downward to DB(0). A data bit is defined as one when the signal is asserted and is defined as zero when the signal is negated.

11.1 (continued)

Data parity DB(P) is odd - The use of parity is a system option. The WREN V SCSI will always generate parity, but has the capability to enable/disable parity detection. See Figure 11.1-1. Parity is not valid during the Arbitration phase.

Greater detail on each of the SCSI Bus signals is found in sections following.

Drive Select

Install jumpers as shown in Figure 11.1-1 for SCSI ID selection. Refer to Figures 10.3-3 and 11.1-1 for the location of the drive select header. The WREN V can have one of eight ID bits selected by installing 0 to 3 jumpers in a binary coded configuration on the drive select header.

11.1.1 Signal Values

Signals may assume true or false values. There are two methods of driving these signals. In both cases, the signal shall be actively driven true, or asserted. In the case of OR-tied drivers, the driver does not drive the signal to the false state, rather the bias circuitry of the bus terminators pulls the signal false whenever it is released by the drivers at every SCSI device. If any driver is asserted, then the signal is true. In the case of non-OR-tied drivers, the signal may be actively driven false, or negated. Negated means that the signal may be actively driven false, or may be simply released (in which case the bias circuitry pulls it false), at the option of the implementor.

11.1.2 OR-Tied Signals

The BSY and RST signals shall be OR-tied only. In the ordinary operation of the bus, these signals are simultaneously driven true by several drivers. No signals other than BSY, RST, and DB(P) are simultaneously driven by two or more drivers, and any signal other than BSY and RST may employ OR-tied or non-OR-tied drivers. DB(P) shall not be driven false during the Arbitration phase. There is no operational problem in mixing OR-tied and non-OR-tied drivers on signals other than BSY and RST.

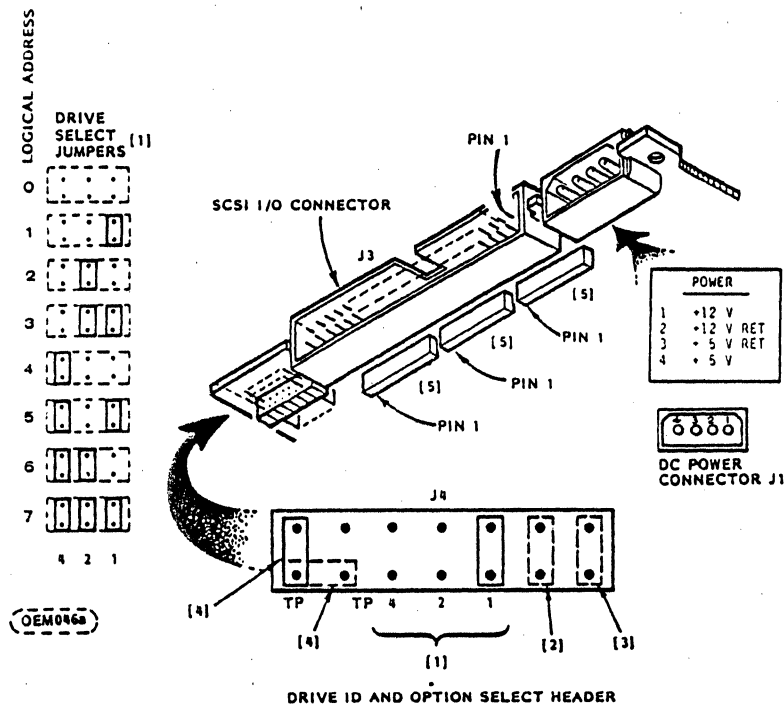

FIGURE 11.1-1. WREN V SCSI DRIVE ID AND OPTION SELECT HEADER

- [1] Drive ID is binary coded jumper position (most significant bit on left) , ie., jumper in position 0 would be Drive ID 1, no jumpers means ID 0.
 - [2] Jumper plug installed enables the Motor Start Option. In this mode of operation the drive will wait for a Start Unit Command from the Host before starting the Motor. If the jumper plug is not installed the Motor will start as soon as DC power is applied to the unit (see Section 14.2.1.11).
 - [3] Jumper plug installed means parity checking by the WREN V is enabled.
 - [4] If the unit is not to be terminated, remove terminator resistor DIPs [5]. If installed, the TP jumper must be installed only in one of the two positions shown with dotted lines in Figure 11.1-1.
- Jumper in vertical position means terminator power (+5 V) is from WREN V power connector. Jumper in horizontal position means terminator power is taken from interface cable. See also paragraph 10.3.4.3.
- If the drive is not terminated, the TP jumper need not be installed.
- [5] Removable terminator SIP resistor modules. See paragraph 10.3.4.2.

11.1.3 Signal Sources

Table 11.1.3-1 indicates which type of SCSI device is allowed to source each signal. All SCSI device drivers that are not active sources shall be in the passive state. Note that the RST signal may be sourced by any SCSI device at any time. The WREN V functions as a target, never as an initiator, and is capable of performing only the reselection function.

TABLE 11.1.3-1. SIGNAL SOURCES

BUS PHASE	SIGNALS					
	BSY	SEL	C/D, I/O, MSG, REQ	I/O	ACK/ATN	DB(7-0,P)
BUS FREE	None	None	None	None	None	None
ARBITRATION SELECTION	All	Winner	None	None	None	SCSI ID
RESELECTION	I&T	Init.	None	Init. [1]	Init.	Init.
COMMAND	I&T	Target	Target	Target	Init.	Target
DATA IN	Target	None	Target	Target	Init.	Init.
DATA OUT	Target	None	Target	Target	Init.	Target
STATUS	Target	None	Target	Target	Init.	Target
MESSAGE IN	Target	None	Target	Target	Init.	Target
MESSAGE OUT	Target	None	Target	Target	Init.	Init.

ALL: The signal shall be driven by all actively arbitrating SCSI devices.

SCSI ID: A unique data bit (the SCSI ID) shall be driven by each actively arbitrating SCSI device: the other seven data bits shall be released (i.e., not driven) by this SCSI device. The parity bit [DB(P)] may be undriven or driven to the true state, but shall never be driven to the false state during this phase.

I&T: The signal shall be driven by the initiator, target, or both, as specified in the Selection phase and Reselection phase.

Initiator: If this signal is driven, it shall be driven only by the active initiator.

None: The signal shall be released; that is, not be driven by any SCSI device. The bias circuitry of the bus terminators pulls the signal to the false state.

Winner: The signal shall be driven by the one SCSI device that wins arbitration.

Target: If the signal is driven, it shall be driven only by the active target.

[1] Initiator forces negation.

11.2 SCSI Bus Timing

Unless otherwise indicated, the delay time measurements for each SCSI device, defined in Paragraphs 11.2.1 through 11.2.14, shall be calculated from signal conditions existing at that SCSI device's own SCSI bus connection. Thus, these measurements (except skew delay) can be made without considering delays in the cable.

11.2.1 Arbitration Delay (2.2 us)

The minimum time a SCSI device shall wait from asserting BSY for arbitration until the Data Bus can be examined to see if arbitration has been won. There is no maximum time.

11.2.2 Assertion Period (90 ns)

The minimum time that a target shall assert REQ while using synchronous data transfers. Also, the minimum time that an initiator shall assert ACK while using synchronous data transfers.

11.2.3 Bus Clear Delay (800 ns)

The maximum time for a SCSI device to stop driving all bus signals after:

- (1) The Bus Free phase is detected (BSY and SEL both negated for a bus settle delay).
- (2) SEL is received from another SCSI device during the Arbitration phase.
- (3) The transition of RST to assertion.

NOTE: For the first condition above, the maximum time for a SCSI device to clear the bus is 1200 ns from BSY and SEL first both negated. If a SCSI device requires more than a bus settle delay to detect Bus Free phase, it shall clear the bus within a Bus Clear delay minus the excess time.

11.2.4 Bus Free Delay (800 ns)

The minimum time that a SCSI device shall wait from its detection of the Bus Free phase (BSY and SEL both negated for a bus settle delay) until its assertion of BSY when going to the Arbitration phase.

11.2.5 Bus Set Delay (1.8 us)

The maximum time for a SCSI device to assert BSY and its SCSI ID bit on the Data Bus after it detects Bus Free phase (BSY and SEL both negated for a bus settle delay) for the purpose of entering the Arbitration phase.

11.2.6 Bus Settle Delay (400 ns)

The time to wait for the bus to settle after changing certain control signals as specified in the protocol definitions.

11.2.7 Cable Skew Delay (10 ns)

The maximum difference in propagation time allowed between any two SCSI bus signals when measured between any two SCSI bus signals.

11.2.8 Data Release Delay (400 ns)

The maximum time for an initiator to release the Data Bus signals following the transition of the I/O signal from negation to assertion.

11.2.9 Deskew Delay (45 ns)

The minimum time required for deskew of certain signals.

11.2.10 Hold Time (45 ns)

The minimum time added between the assertion of REQ or ACK and the changing of the data lines to provide hold time in the initiator or target, respectively, while using synchronous data transfers.

11.2.11 Negation Period (90 ns)

The minimum time that a target shall negate REQ while using synchronous data transfers. Also, the minimum time that an initiator shall negate ACK while using synchronous data transfers.

11.2.12 Reset Hold Time (25 us)

The minimum time for which RST is asserted. There is no maximum time.

11.2.13 Selection Abort Time (200 us)

The maximum time that a target (or initiator) shall take from it's most recent detection of being selected (or reselected) until asserting a BSY response. This timeout is required to ensure that a target (or initiator) does not assert BSY after a Selection (or Reselection) phase has been aborted. This is not the selection timeout period; see Sections 12.1.3.5 and 12.1.4.2 for a complete description.

11.2.14 Selection Timeout Delay (250 ms recommended)

The minimum time an initiator (or target) should wait for a BSY response during the Selection (or Reselection) phase before starting the timeout procedure. Note this is only a recommended time period. The WREN V SCSI implements this 250 ms selection timeout delay.

11.2.15 Transfer Period (set during a Message phase)

The minimum time allowed between the leading edges of successive REQ pulses and of successive ACK pulses while using synchronous data transfers. (See Sections 12.1.5.2 and 12.5.4.)

12.0 LOGICAL CHARACTERISTICS

All of the operations of the SCSI bus as described in Section 12 are supported by the WREN V, unless otherwise stated. The WREN V always functions as the target, never the initiator.

12.1 SCSI BUS PHASES

WREN V responds to 8 distinct bus phases.

Bus Free phase
 Arbitration phase
 Selection phase
 Reselection phase

Command phase
 Data(In and Out)
 Status (In Only)
 Message (In and Out)

} These phases are collectively termed
 the Information Transfer phase.

The SCSI Bus can never be in more than one phase at a time.

12.1.1 Bus Free Phase

The Bus Free phase indicates that no SCSI device is actively using the SCSI bus and it is available for subsequent users.

SCSI devices shall detect the Bus Free phase after SEL and BSY are both false for at least a bus settle delay.

SCSI devices shall release all SCSI bus signals within a bus clear delay after BSY and SEL are continuously negated for a bus settle delay. If a SCSI device requires more than a bus settle delay to detect the Bus Free phase, it shall release all SCSI bus signals within a bus clear delay minus the excess time to detect the Bus Free phase. The total time to clear the SCSI bus shall not exceed a bus settle delay plus a bus clear delay.

If the initiator detects the Bus Free phase (except as a result of a Reset condition, an Abort message, or a Bus Device Reset message) without first receiving a Disconnect or Command Complete message, it shall be considered to be an error condition. If the target intentionally creates this condition, the target shall:

1. Clear the current command, if any, for that initiator.
2. Set up Request Sense data with appropriate Sense Key and Error Code if the LUN is known.

Whenever an initiator detects an unexpected Bus Free, it should attempt to select and issue Request Sense to determine if the previous command was:

1. Aborted with valid Request Sense data, or
2. Aborted without any valid Request Sense data.

12.1.2 Arbitration Phase

The Arbitration phase allows one SCSI device to gain control of the SCSI bus so that it can assume the role of an initiator or target. The WREN V will arbitrate for the bus only as a target implementing reselection. The WREN V supports arbitration by multiple SCSI devices.

The procedure for a SCSI device to obtain control of the SCSI bus is as follows:

1. The SCSI device shall first wait for the Bus Free phase to occur. The Bus Free phase is detected when BSY and SEL are simultaneously and continuously negated for a minimum of a bus settle delay. (Implementers note: This bus settle delay is necessary because a transmission line phenomenon known as a "Wire-OR glitch" may cause BSY to briefly appear negated, even though it is being asserted.)
2. The SCSI device shall wait a minimum of a bus free delay after detection of the Bus Free phase (i.e. after BSY and SEL are both negated for a bus settle delay) before driving any signal.
3. Following the bus free delay in Step (2), the SCSI device may arbitrate for the SCSI bus by asserting both BSY and it's own SCSI ID, however the SCSI device shall not arbitrate (i.e. assert BSY and it's SCSI ID) if more than a bus set delay has passed since the Bus Free phase was last observed. (Implementers Note: There is no maximum delay before asserting BSY and the SCSI ID following the bus free delay in Step (2) as long as the bus remains in the Bus Free phase. However, SCSI devices that delay longer than a bus settle delay plus a bus set delay from the time when BSY and SEL are first negated may fail to participate in arbitration when competing with faster SCSI devices.)

12.1.2 continued

4. After waiting at least an arbitration delay (measured from it's assertion of BSY) the SCSI device shall examine the Data Bus. If a higher priority SCSI ID bit is true on the Data Bus [DB(7) is the highest], the SCSI device has lost the arbitration and the SCSI device must release it's signals and return to Step (1). If no higher priority SCSI ID bit is true on the Data Bus, the SCSI device has won the arbitration and it shall assert SEL. Any other SCSI device that is participating in the Arbitration phase has lost the arbitration and shall release BSY and it's SCSI ID bit within a bus clear delay after SEL becomes true. A SCSI device that loses arbitration may return to Step (1).
5. The SCSI device that wins arbitration shall wait at least a bus clear delay plus a bus settle delay after asserting SEL before changing any signals.

NOTE: The SCSI ID bit is a single bit on the Data Bus that corresponds to the SCSI device's unique SCSI address. All other seven Data Bus bits shall be released by the SCSI device. Parity is not valid during the Arbitration phase, DB(P) may be undriven or driven to the true state, but shall not be driven to the false state.

12.1.3 Selection Phase

The Selection phase allows an initiator to select a target for the purpose of initiating some target function (e.g., Read or Write command).

NOTE: During the Selection phase the I/O signal shall be negated so this phase can be distinguished from the Reselection phase.

12.1.3.1 Nonarbitrating System

In systems with the Arbitration phase not implemented, the initiator shall first detect the Bus Free phase and then wait a minimum of a bus clear delay. Then, except in certain single initiator environments with initiators employing the single initiator option (see 12.1.3.4), the initiator shall assert the desired target's SCSI ID and it's own initiator SCSI ID on the Data Bus. After two deskew delays, the initiator shall assert SEL.

12.1.3.2 Arbitrating Systems

In systems with the Arbitration phase implemented, the SCSI device that won the arbitration has both BSY and SEL asserted and has delayed at least a bus clear delay plus a bus settle delay before ending the Arbitration phase. The SCSI device that won the arbitration becomes an initiator by releasing I/O. Except in certain single initiator environments with initiators employing the single initiator option (see 12.1.3.4), the initiator shall set the Data Bus to a value which is the OR of it's SCSI ID bit and the target's SCSI ID bit. The initiator shall then wait at least two deskew delays and release BSY. The initiator shall then wait at least a bus settle delay before looking for a response from the target.

12.1.3.3 All Systems

In all systems, the target shall determine that it is selected when SEL and it's SCSI ID bit are true and BSY and I/O are false for at least a bus settle delay. The selected target will examine the Data Bus in order to determine the SCSI ID of the selecting initiator unless the initiator employed the single initiator option (see 12.1.3.4). The selected target shall then assert BSY within a selection abort time of it's selection; this is required for correct operation of the timeout procedure. In systems with parity implemented, the target shall not respond to a selection if bad parity is detected. Also, if more than two SCSI ID bits are on the Data Bus, the target shall not respond to selection. At least two deskew delays after the initiator detects BSY is asserted, it shall release SEL and may change the Data Bus.

12.1.3.4 Single Initiator Option

Initiators that do not implement the Reselection phase, and do not operate in the multiple initiator environment, are allowed to set only the target's SCSI ID bit during the Selection phase. This makes it impossible for the target to determine the initiator's SCSI ID.

12.1.3.5 Selection Time Out Procedure

A Selection timeout procedure is specified for clearing the SCSI bus. If the initiator waits a minimum of a selection timeout delay and there has been no BSY response from the target, the initiator shall continue asserting SEL and shall release the Data Bus. If the initiator has not detected BSY to be asserted after at least a selection abort time plus two deskew delays, the initiator shall release SEL allowing the SCSI bus to go to the Bus Free phase. SCSI devices shall ensure when responding to a selection that the selection was still valid within a selection abort time of their assertion of BSY. Failure to comply with this requirement could result in an improper selection (two targets connected to the same initiator, wrong target connected to an initiator, or a target connected to no initiator).

The WREN V supports systems that implement this procedure.

12.1.4 Reselection Phase

Reselection is a phase that allows a target to reconnect to an initiator for the purpose of continuing some operation that was previously started by the initiator but was suspended by the target (i.e., the target disconnected by allowing a Bus Free phase to occur before the operation was complete).

Reselection can be used only in systems that have Arbitration phase implemented.

The WREN V implements the Reselection phase if the system is capable of supporting Reselection.

12.1.4.1 Reselection Procedure

Upon completing the Arbitration phase, the winning SCSI device has both BSY and SEL asserted and has delayed at least a bus clear delay plus a bus settle delay. The winning SCSI device becomes a target by asserting the I/O signal. That device shall also set the Data Bus to a value that is the OR of its SCSI ID bit and the initiator's SCSI ID bit. The target shall wait at least two deskew delays and release BSY. The target shall then wait at least a bus settle delay before looking for a response from the initiator.

12.1.4.1 continued

The initiator shall determine that it is reselected when SEL, I/O, and it's SCSI ID bit are true and BSY is false for at least a bus settle delay. The reselected initiator may examine the Data Bus to determine the SCSI ID of the reselecting target.

The reselected initiator shall then assert BSY within a selection abort time of it's most recent detection of being reselected; this is required for correct operation of the timeout procedure. In systems with parity implemented, the initiator shall not respond to Reselection if bad parity is detected. The initiator shall not respond to a Reselection if more than two SCSI ID bits are on the Data Bus.

After the target detects BSY, it shall also assert BSY and wait at least two deskew delays and then release SEL. The target may then change the I/O signal and the Data Bus. After the reselected initiator detects SEL false, it shall release BSY. The target shall continue asserting BSY until the target is ready to relinquish the SCSI bus.

NOTE

When the target is asserting BSY, a transmission line phenomenon known as a "Wire-OR glitch" may cause BSY to appear false for up to a round trip propagation delay following the release of BSY by the initiator. This is the reason why the Bus Free phase is recognized only after both BSY and SEL are continuously false for a minimum of a bus settle delay. Cables longer than 25 metres should not be used even if the chosen driver, receiver, and cable provide adequate noise margins, because they increase the duration of the glitch and could cause SCSI devices to inadvertently detect the Bus Free phase.

12.1.4.2 Reselection Timeout Procedure

This Reselection timeout procedure is specified for clearing the SCSI bus during a Reselection phase. If the target waits a minimum of a selection timeout period and there has been no BSY response from the initiator, the target shall continue asserting SEL and I/O and shall release all Data Bus signals. If the target has not detected BSY to be true after at least a selection abort time plus two deskew delays, the target shall release SEL and I/O allowing the SCSI bus to go to the Bus Free phase. SCSI devices that respond to Reselection shall ensure that the Reselection was still valid within a selection abort time of their assertion of BSY. Failure to comply with this requirement could result in an improper Reselection (two initiators connected to the same target or the wrong initiator connected to a target).

If Reselection fails, the current command will be aborted. If an initiator times out while waiting to be reselected, the initiator should attempt to select and issue Request Sense to determine if the previous command is:

1. Still in process (Busy Status will be returned),
2. Aborted with valid Request Sense data, or
3. Aborted without valid Request Sense data.

12.1.5 Information Transfer Phases

NOTE: The Command, Data, Status, and Message phases are grouped together as information transfer phases because they are all used to transfer data or control information via the Data Bus. The actual contents of the information is beyond the scope of this section.

The C/D, I/O, and MSG signals are used to distinguish between the different information transfer phases. (See Table 12.1.5-1). The target drives these three signals and therefore controls all changes from one phase to another. The initiator can request a Message Out phase by asserting ATN, while the target can cause the Bus Free phase by releasing MSG, C/D, I/O, and BSY.

12.1.5 continued

TABLE 12.1.5-1. INFORMATION TRANSFER PHASES

SIGNAL			PHASE NAME	DIRECTION OF TRANSFER	COMMENT
MSG	C/D	I/O			
0	0	0	DATA OUT	Initiator to target	Data
0	0	1	DATA IN	Initiator from target	Phase
0	1	0	COMMAND	Initiator to target	
0	1	1	STATUS	Initiator from target	
1	0	0	*		
1	0	1	*		
1	1	0	MESSAGE OUT	Initiator to Target	Message
1	1	1	MESSAGE IN	Initiator from Target	Phase

Key: 0 = False, 1 = True, * = Reserved

The information transfer phases use one or more REQ/ACK handshakes to control the information transfer. Each REQ/ACK handshake allows the transfer of one byte of information. During the information transfer phases BSY shall remain true and SEL shall remain false. Additionally, during the information transfer phases, the target shall continuously envelope the REQ/ACK handshake(s) with C/D, I/O, and MSG in such a manner that these control signals are valid for a bus settle delay before the assertion of REQ of the first handshake and remain valid until the negation of ACK at the end of the last handshake.

12.1.5.1 Asynchronous Information Transfer

The target shall control the direction of information transfer by means of the I/O signal. When I/O is true, information shall be transferred from the target to the initiator. When I/O is false, information shall be transferred from the initiator to the target.

If I/O is true (transfer to the initiator), the target shall first drive DB(7-0, P) to their desired values, delay at least one deskew delay plus a cable skew delay, then assert REQ. DB(7-0, P) shall remain valid until ACK is true at the target. The initiator shall read DB(7-0, P) after REQ is true, then signal it's acceptance of the data by asserting ACK. When ACK becomes true at the target, the target may change or release DB(7-0, P) and shall negate REQ. After REQ is false the initiator shall negate ACK. After ACK is false, the target may continue the transfer by driving DB(7-0, P) and asserting REQ, as described above.

12.1.5.1 continued

If I/O is false (transfer to the target) the target shall request information by asserting REQ. The initiator shall drive DB(7-0, P) to their desired values, delay at least one deskew delay plus a cable skew delay and assert ACK. The initiator shall continue to drive the DB(7-0,P) until REQ is false. When ACK becomes true at the target, the target shall read DB(7-0, P), then negate REQ. When REQ becomes false at the initiator, the initiator may change or release DB(7-0, P) and shall negate ACK. The target may continue the transfer by asserting REQ, as described above.

12.1.5.2 Synchronous Data Transfer

Synchronous data transfer may be used only in the data phase if previously agreed to by the initiator and target through the message system (see SYNCHRONOUS DATA TRANSFER REQUEST message 12.5.4). The messages determine the use of synchronous mode by both SCSI devices and establish a REQ/ACK offset and a transfer period.

The REQ/ACK offset specifies the maximum number of REQ pulses that can be sent by the target in advance of the number of ACK pulses received from the initiator, establishing a pacing mechanism. If the number of REQ pulses exceeds the number of ACK pulses by the REQ/ACK offset, the target shall not assert REQ until the next ACK pulse is received. A requirement for successful completion of the data phase is that the number of ACK and REQ pulses be equal.

The target shall assert the REQ signal for a minimum of an assertion period. The target shall wait at least the greater of a transfer period from the last transition of REQ to true or a minimum of a negation period from the last transition of REQ to false before asserting the REQ signal.

The initiator shall send one pulse on the ACK signal for each REQ pulse received. The initiator shall assert the ACK signal for a minimum of an assertion period. The initiator shall wait at least the greater of a transfer period from the last transition of ACK to true or for a minimum of a negation period from the last transition of ACK to false before asserting the ACK signal.

12.1.5.2 continued

If I/O is true (transfer to the initiator), the target shall first drive DB(7-0,P) to their desired values, wait at least one deskew delay plus one cable skew delay, then assert REQ. DB(7-0,P) shall be held valid for a minimum of one deskew delay plus one cable skew delay plus one hold time after the assertion of REQ. The target shall assert REQ for a minimum of an assertion period. The target may then negate REQ and change or release DB(7-0,P). The initiator shall read the value on DB(7-0,P) within one hold time of the transition of REQ to true. The initiator shall then respond with an ACK pulse.

If I/O is false (transfer to the target), the initiator shall transfer one byte for each REQ pulse received. After receiving a REQ pulse, the initiator shall first drive DB(7-0,P) to their desired values, delay at least one deskew delay plus one cable skew delay, then assert ACK. The initiator shall hold DB(7-0,P) valid for at least one deskew delay plus one cable skew delay plus one hold time after the assertion of ACK. The initiator shall assert ACK for a minimum of an assertion period. The initiator may then negate ACK and may change or release DB(7-0,P). The target shall read the value of DB(7-0,P) within one hold time of the transition of ACK to true.

12.1.6 Command Phase

The Command phase allows the target to request command information from the initiator.

The target shall assert the C/D signal and negate the I/O and MSG signals during the REQ/ACK handshake(s) of this phase.

12.1.7 Data Phase

The Data phase is a term that encompasses both the Data In phase and the Data Out phase.

12.1.7.1 Data In Phase

The Data In phase allows the target to request that it send data to the initiator.

The target shall assert the I/O signal and negate the C/D and MSG signals during the REQ/ACK handshake(s) of this phase.

12.1.7.2 Data Out Phase

The Data Out phase allows the target to request that data be sent to it from the initiator.

The target shall negate the C/D, I/O, and MSG signals during the REQ/ACK handshake(s) of this phase.

12.1.8 Status Phase

The Status phase allows the target to request that it send status information to the initiator. See section 15.0 for details.

The target shall assert C/D and I/O and negate the MSG signal during the REQ/ACK handshake of this phase.

12.1.9 Message Phase

The Message phase is a term that references either a Message In or a Message Out phase. Multiple messages may be sent during either phase. The first byte transferred in either of these phases shall be either a single byte message or the first byte of a multiple byte message. Multiple byte messages shall be wholly contained within a single message phase.

12.1.9.1 Message IN Phase

The Message In phase allows the target to request that it send message(s) to the initiator.

The target shall assert C/D, I/O, and MSG during the REQ/ACK handshake(s) of this phase.

12.1.9.2 Message Out Phase

The Message Out phase allows the target to request that message(s) be sent from the initiator to the target. The target may invoke this phase at its convenience in response to the Attention condition (see 12.2.1) created by the initiator.

The target shall assert C/D and MSG and negate I/O during the REQ/ACK handshake(s) of this phase. The target shall handshake byte(s) in this phase until ATN goes false, unless an error occurs (see Message Reject, 12.5.2).

12.1.9.2 continued

If the target detects one or more parity error(s) on the message byte(s) received, it may indicate its desire to retry the message(s) by asserting REQ after detection ATN has gone false and before changing to any other phase. The initiator, upon detecting this condition, shall resend all of the previous message byte(s) sent during this phase. When resending more than one message byte, the initiator shall assert ATN before asserting ACK on the first byte and shall maintain ATN asserted until the last byte is sent as described in 12.2.1.

If the target receives all of the message byte(s) successfully (i.e., no parity errors), it shall indicate that it does not wish to retry by changing to any information transfer phase other than the Message Out phase and transfer at least one byte. The target may also indicate that it has successfully received the message byte(s) by changing to the Bus Free phase (e.g., Abort or Bus Device Reset messages).

Only the following combinations of messages will be accepted during the same Message Out transfer (and only immediately after Selection):

1. Identify message followed by Abort message
2. Identify message followed by Bus Device Reset message
3. Identify message followed by No Operation message
4. Identify message followed by Synchronous Data Xfer Request message

If a target receives illegal multiple messages, it will send a Message Reject message, go to Bus Free, and abort any command in process for that initiator.

12.1.10 Signal Restrictions Between Phases

When the SCSI bus is between two information transfer phases, the following restrictions shall apply to the SCSI bus signals:

1. The BSY, SEL, REQ, and ACK signals shall not change.

12.1.10 continued

2. The C/D, I/O, MSG, and Data Bus signals may change. When switching the Data Bus direction from Out (initiator driving) to In (target driving), the target shall delay driving the Data Bus by at least a data release delay plus settle delay after asserting the I/O signal and the initiator shall release the Data Bus no later than a data release delay after the transition of the I/O signal to true. When switching the Data Bus direction from In (target driving) to Out (initiator driving), the target shall release the Data Bus no later than a deskew delay after negating the I/O signal.
3. The ATN and RST signals may change as defined under the descriptions for the Attention condition (12.2.1) and Reset condition (12.2.2).

12.2 SCSI BUS CONDITIONS

The SCSI bus has two asynchronous conditions; the Attention condition and the Reset condition. These conditions cause the SCSI device to perform certain actions and can alter the phase sequence.

12.2.1 Attention Condition

The Attention condition allows an initiator to inform a target that the initiator has a message ready. The target will get this message at its convenience by performing a Message Out phase.

The initiator creates the Attention condition by asserting ATN at any time except during the Arbitration or Bus Free phase.

The initiator must assert the ATN signal before asserting ACK for the last byte transferred in a bus phase for the Attention condition to be honored before transition to a new bus phase. An ATN asserted later may not be honored until a later bus phase. The WREN V will respond with Message Out phase as follows:

1. If ATN occurs during a Data phase, Message Out will occur at a convenient time. It may not occur until several logical blocks after ATN is first asserted.
2. If ATN occurs during a Command phase, Message Out will occur after transfer of all Command Descriptor Block bytes has been completed.

12.2.1 continued

3. If ATN occurs during a Status phase, Message Out will occur after the status byte has been acknowledged by the initiator.
4. If ATN occurs during a Message In phase, Message Out will occur after the last byte of the current message has been acknowledged by the initiator.
5. If ATN occurs during a Selection or Reselection phase, Message Out will occur immediately after that Selection or Reselection phase.

The initiator shall keep ATN asserted if more than one byte is to be transferred. The initiator may negate the ATN signal at any time except it shall not negate the ATN signal while the ACK signal is asserted during a Message Out phase. Recommended practice is that the initiator negates ATN while REQ is true and ACK is false during the last REQ/ACK handshake of the Message Out phase.

12.2.2 Reset Condition

The Reset condition is used to immediately clear all SCSI devices from the bus. This condition shall take precedence over all other phases and conditions. During the Reset condition, the state of all SCSI bus signals other than RST is not defined.

The WREN V will never assert the Reset signal.

All SCSI devices shall release all SCSI bus signals (except RST) within a bus clear delay of the transition of RST to true. The Bus Free phase always follows the Reset condition.

The WREN V implements only the "hard" Reset option. Upon detection of the Reset condition, the WREN V shall:

1. Clear all uncompleted commands,
2. Release all SCSI device reservations,
3. Return any SCSI device operating modes (Mode Select, etc) to their default conditions.
4. Activate Unit Attention Condition for all Initiators.

12.3 SCSI BUS PHASE SEQUENCES

The order in which phases are used on the SCSI bus follows a prescribed sequence.

In all systems, the Reset condition can abort any phase and is always followed by the Bus Free phase. Also, any other phase can be followed by the Bus Free phase.

12.3.1 Nonarbitrating System

For systems in which the Arbitration phase is not implemented, the allowable sequences are shown in Figure 12.3-1. The normal progression is from the Bus Free phase to Selection, and from Selection to one or more of the information transfer phases (Command, Data, Status, or Message).

12.3.2 Arbitrating Systems

For systems in which the Arbitration phase is implemented, the allowable sequences are shown in Figure 12.3-2. The normal progression is from the Bus Free phase to Arbitration, from Arbitration to Selection or Reselection, and from Selection or Reselection to one or more of the information transfer phases (Command, Data, Status, or Message).

12.3.3 All Systems

There are no restrictions on the sequences between information transfer phases. A phase type may even be followed by the same phase type (e.g., a Data phase may be followed by another Data phase).

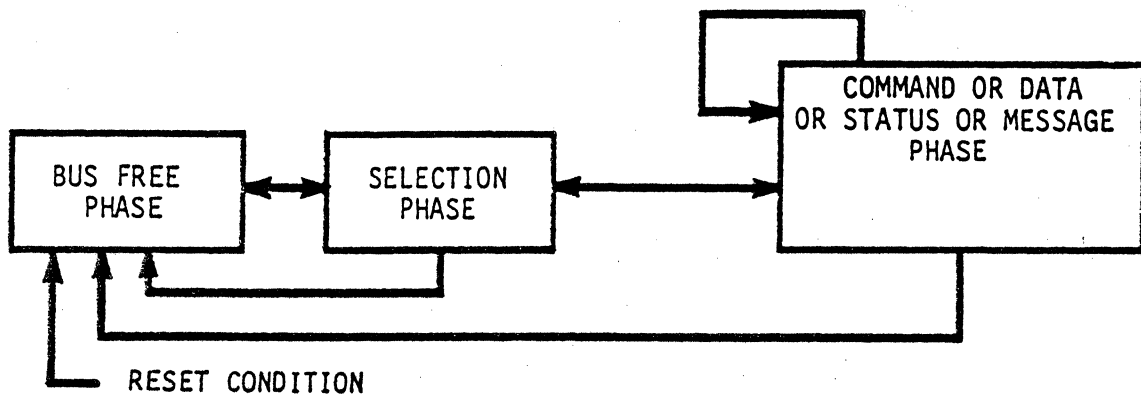

FIGURE 12.3-1. PHASE SEQUENCES WITHOUT ARBITRATION

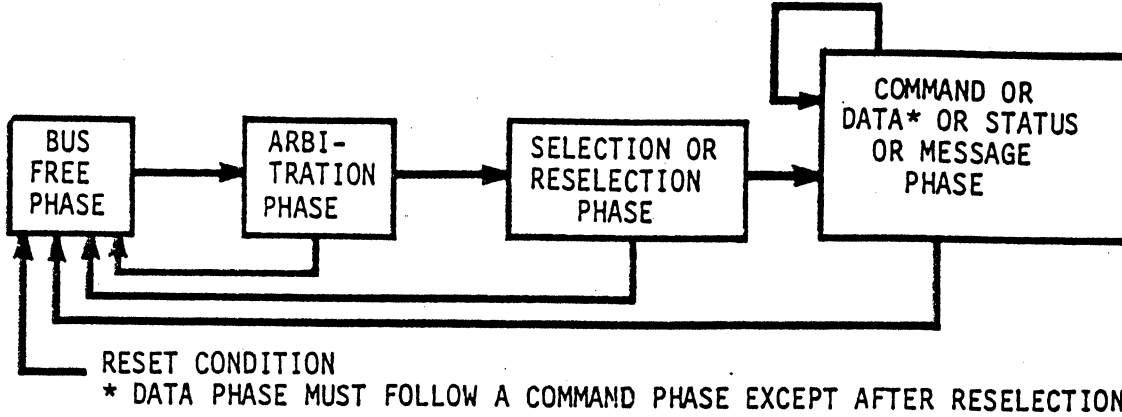

FIGURE 12.3-2. PHASE SEQUENCES WITH ARBITRATION

12.4 SCSI POINTERS

WREN V supports systems that use the pointer philosophy described in the following paragraphs.

Consider the system shown in Figure 12.4-1 in which an initiator and target communicate on the SCSI bus in order to execute a command.

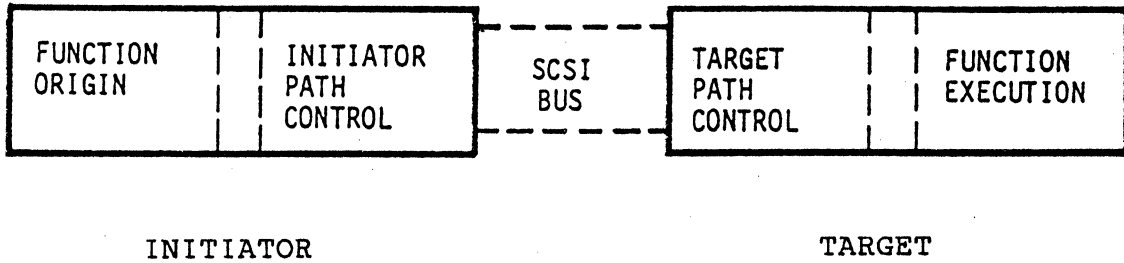

FIGURE 12.4-1. SIMPLIFIED SCSI SYSTEM

12.4 continued

The SCSI architecture provides for sets of pointers to be kept within each initiator Path Control area (see Figure 12.4-1). These pointers are in sets of three pointers per set. The pointers in each set point to three storage area sections in the initiator. The three sections contain the following information:

1. A command from initiator to target.
2. Status (from target) associated with the command.
3. Data (to/from target) associated with the command.

Of these three-pointer sets there are two types:

1. Current (active) pointers
(one set per initiator only).
2. Saved pointers
(one or more sets per initiator, up to seven sets total).

The use of these two types of pointers is described in the following paragraphs.

12.4.1 Current Pointers

Current Pointers represent the current state of the interface between the initiator and the target it is currently connected to and servicing. The pointers for the current command remain in the Current Pointer registers from the time they are put there after the completion of all activities associated with previous command until the logic of the Initiator dictates a new command shall be executed. Normally, successful receipt by the initiator of good status associated with current command triggers the initiator to insert a new set of the three "current" pointers for the next command. The initiator does not wait for the Command Complete signal before deciding whether to retry the current command or transfer in new command pointers. If the current command was never satisfactorily completed, the initiator logic may dictate that some special response action be taken, such as restoring the value in the current pointer registers to their beginning values so the current command can be reset*, or sending a command such as a Request Sense command to the target, or the initiator could ignore the unsatisfactorily completed command and send the next originally scheduled command.

*See following page for note.

12.4.1 continued

*An example of this is if the drive detects a parity error in the data out from the current command, it sends the "Restore Pointers" message to the initiator. In this case, the Restore Pointers request causes the initiator to restore the current pointers to the values existing at the beginning of the current command so the current command can be resent. The "beginning" pointer values point to the first byte of the current Command Descriptor Block, the first byte of the area set aside for status to be returned and the first byte of the area set aside for data associated with the current command. (See paragraph 12.5.2 for a detailed description of operations resulting from the Restore Pointers message).

12.4.2 Saved Pointers

Saved pointers point to initiator storage locations where command, status and data information are stored for a command that was saved at some point in the past. There is one set of saved pointers for the current command for each target on the interface bus that is currently active (whether or not it is currently connected to the initiator). The saved command pointer always points to the first byte of the Command Descriptor Block (see paragraph 13.2) for the "current" command for each target, the saved status pointer always points to the first byte of the area used for the status associated with the command, and the saved data pointer points to some location (not necessarily the beginning) in the area used for data associated with the command. When a target disconnects the initiator saves the current pointers. Before a target disconnects it may send a Save Data Pointers message to the initiator which copies the data pointer that is for the current command for that target into the location set aside for that target's saved pointers. When a target reconnects, the initiator performs a restore pointers operation which copies the saved pointers for the reconnected target into the initiator current pointer registers so that the current command for that target may continue its operation from where it left off before disconnecting. If the target had sent a Save Data Pointer message previously, the current data pointer will point to the place in the data store area where operations left off, otherwise the data pointer will point to the beginning of the data area.

12.5 MESSAGE SYSTEM SPECIFICATION

The message system allows communication between an initiator and target for the purpose of physical path management.

12.5.1 Message Protocol

WREN V supports systems that accommodate only the Command Complete message, or systems that can accommodate additional messages. WREN V is always Logical Unit (LUN) address zero.

SCSI devices indicate their ability to accommodate more than the Command Complete message by asserting or responding to the ATN signal. The initiator indicates this in the Selection phase by asserting ATN before the SCSI bus condition of SEL true, and BSY false. If the target hasn't received ATN by this point, it will assume the initiator doesn't support disconnection or messages other than Command Complete. If the ATN signal is asserted later, it will be ignored until after the next Bus Free phase. The target indicates its ability to accommodate more messages by responding to the Attention condition with the Message Out phase after going through the Selection phase.

For SCSI devices that support messages other than Command Complete, the first message sent by the initiator after the Selection phase shall be the Identify message. This allows the establishment of the physical path for a particular logical unit specified by the initiator. After the Reselection phase, the target's first message shall be Identify. This allows the physical path to be reestablished for the target's specified logical unit number (always zero for WREN V). An initiator may send the Abort message or the Bus Device Reset message instead of the Identify message, as the first message.

Whenever a physical path is established in an initiator that can accommodate disconnection and reconnection, the initiator shall ensure that the active pointers of the physical path are equal to the save pointers for that particular logical unit number. The initiator performs a restore pointers operation as a result of connect or reconnect. (No Restore Pointers message required from the Target).

12.5.2 Messages

The single byte messages supported by the WREN V are listed in Table 12.5.2-1. Their code values are given a direction specification. Detailed descriptions follow the table. Messages other than those listed will be answered with a Message Reject message.

TABLE 12.5.2-1. MESSAGE CODES

CODE	DESCRIPTION	[1] DIRECTION
00H	COMMAND COMPLETE	IN
01H/01H	SYNC DATA TRANSFER REQUEST	IN OUT
02H	SAVE DATA POINTER	IN
03H	RESTORE POINTERS	IN
04H	DISCONNECT	IN
05H	INITIATOR DETECTED ERROR	OUT
06H	ABORT	OUT
07H	MESSAGE REJECT [2]	IN OUT
08H	NO OPERATION	OUT
09H	MESSAGE PARITY ERROR	OUT
0CH	BUS DEVICE RESET	OUT
80H--FFH	IDENTIFY	IN OUT

[1] IN = WREN V TO INITIATOR
 OUT = INITIATOR TO WREN V

[2] WREN V WILL NOT RESEND (RETRY) THE ORIGINAL MESSAGE

12.5.2 continued

Command Complete 00H - This message is sent from a target to an initiator to indicate the execution of a command has terminated and that valid status has been sent to the initiator. After successfully sending this message, the target shall go to the Bus Free phase by releasing BSY.

NOTE: The command may have been executed successfully or unsuccessfully as indicated in the status.

Extended Message 01H - This message is sent from either the initiator or the target as the first byte of a multiple byte message. (See Paragraph 12.5.3 for descriptions of extended messages.)

Save Data Pointer 02H - This message is sent from the currently attached target to direct the initiator to save a copy of the presently active data pointer. (See Paragraph 12.4 for a definition of pointers.)

Restore Pointers 03H - This message is sent from the target to direct the initiator to restore to the active state the most recently saved pointers for the currently attached WREN V. Pointers to the command, data, and status locations for the logical unit shall be restored to the active pointers. Command and status pointers shall be restored to the beginning of the present command and status areas. The data pointer shall be restored to the value at the beginning of the data area if a Save Data Pointer message was never sent previously, or to the value at the point at which the last Save Data Pointer message occurred for currently attached WREN V.

Disconnect 04H - This message is sent from a target to inform an initiator that the present physical path is going to be broken (the target plans to disconnect by releasing BSY), but that a later reconnect will be required in order to complete the current operation. If the initiator detects the Bus Free phase (other than a result of a Reset condition) without first receiving a Disconnect or Command Complete message, the initiator shall consider this a catastrophic error condition. If the target intentionally creates this error condition, the target shall clear the current command. This type of disconnect shall not cause the initiator to save the data pointer. Note: If Disconnect messages are used to break a long data transfer into two or more shorter transfers, then a Save Data Pointer message will be issued before each Disconnect message. The WREN V will disconnect when a substantial delay is anticipated. These situations occur after receipt of a Command Descriptor Block or during a data transfer.

12.5.2 continued

Initiator Detected Error 05H - This message is sent from an initiator to inform a target an error (e.g. parity error) has occurred that does not preclude the target from retrying the operation. Since present pointer integrity is not assured, a Restore Pointers message shall be sent by the target to cause the pointers to be restored to their defined prior state. An initiator should not issue this message unless it will accept the Restore Pointers message. If the target is not sure it can recover properly, Check Condition status will be created with Sense Key of Aborted Command.

Abort 06H - This message is sent from the initiator to the target to clear the present operation. If a logical unit has been identified, all pending data and status for the issuing initiator from the affected logical unit shall be aborted and target shall go to the Bus Free phase. Pending data and status for other initiators shall not be cleared. If a logical unit has not been identified, the target shall go to the Bus Free phase. No status or ending message shall be sent for the operation.

Message Reject 07H - This message is sent from either the initiator or target to indicate that the last message it received was inappropriate or has not been implemented. The WREN V will not resend (retry) the original message.

12.5.2 continued

The WREN V response to a message reject message will depend on what the original message was.

ORIGINAL MESSAGE

RECOVERY ACTION

Command Complete
Synchronous Request

Go to Bus Free state anyway.
Assume asynchronous transfers and
continue.

Save Data Pointer

If Data In Phase, don't
disconnect and continue data
transfer command. If Data Out
Phase, continue disconnect
sequence.

Restore Pointers

Terminate command immediately
with Check Condition status
and Hardware Error in Sense
Key.

Disconnect

Don't disconnect and continue
command normally.

Message Reject

Terminate command immediately
with Check Condition status and
Hardware Error in Sense Key.

Linked Cmd Complete
Identify

Go to Bus Free phase.
Go to Bus Free (catastrophic
error), save Aborted CMD in the
Sense Key.

12.5.2 continued

No Operation 08H - This message is sent from an initiator in response to a target's request for a message when the initiator does not currently have any other valid message to send.

Message Parity Error 09H - This message is sent from the initiator to the target to indicate that one or more bytes in the last message it received had a parity error. The WREN V will attempt to resend the original message one time. If the retry attempt also results in a parity error, the target will go to Bus Free phase.

In order to indicate it's intentions of sending this message, the initiator shall assert the ATN signal before it's release of ACK for the REQ/ACK handshake of the message that has the parity error. This provides an interlock so that the target can determine which message has the parity error.

Bus Device Reset OCH - This message is sent from an initiator to direct a target to clear all current commands. This message forces the SCSI device to an initial state with no operations pending for any initiator. Upon recognizing this message, the target shall go to the Bus Free phase.

12.5.2 continued

Identify 80H to FFH - These messages are sent by either the initiator (after Selection phase) or the target (after Reselection phase) to establish the physical path connection between an initiator and target.

Bit 7 - This bit is always set to one to distinguish these messages from the other messages.

Bit 6 - This bit is set to one only by the initiator. When set to one, it indicates the initiator has the ability to accommodate disconnection and reconnection. When set to zero, the WREN V will not attempt to disconnect.

Bits 5-3 - Reserved

Bits 2-0 - These bits specify a logical unit number in a target. Always "0" for WREN V.

When sent from a target to an initiator during reconnection, an implied Restore Pointers message shall be performed by the initiator before completion of this message.

If an initiator specifies an invalid LUN in the Identify message, the WREN V will accept the Identify message but will reject the next command. See Paragraph 13.2.2.

12.5.3 Extended Messages

Extended messages except for the Synchronous Data Transfer Request are not implemented. WREN V will respond with a Message Reject message after any other extended message is received.

The Extended message format to be used by WREN V is shown in Section 12.5.4, "Synchronous Data Transfer Request Message".

12.5.4 Synchronous Data Transfer Request Message

TABLE 12.5.4-1. SYNCHRONOUS DATA TRANSFER REQUEST

BYTE	VALUE	DESCRIPTION
0	01H	Extended message
1	03H	Extended message length
2	01H	Synchronous Data Transfer Request code
3	mH	Transfer period (mH times 4 ns)
4	xH	REQ/ACK offset

12.5.4 continued

If an initiator desires to transfer data synchronously with a target, a pair of Synchronous Data Transfer Request messages (Table 12.5.4-1) are exchanged between an initiator and a target whenever one of the devices recognizes that it has not communicated with the other SCSI device since receiving the last "hard" Reset condition or a Bus Device Reset message. The SCSI devices may also exchange messages to establish synchronous data transfer when requested to do so. The message exchange establishes the transfer period and the REQ/ACK offset. The transfer period is the minimum time between leading edges of successive REQ pulses and of successive ACK pulses.

The REQ/ACK offset is the maximum number of REQ pulses that may be outstanding before a corresponding ACK pulse is received at the target. A REQ/ACK offset value of zero shall indicate asynchronous mode; a value of FFH shall indicate unlimited offset.

If the initiator recognizes that negotiation is required, it asserts ATN and sends a SYNCHRONOUS DATA TRANSFER REQUEST message indicating an REQ/ACK offset and minimum transfer period. The REQ/ACK offset is chosen to prevent initiator buffer overflows, while the minimum transfer period is chosen to meet the data handling requirements of the initiator. The target responds in any of the following ways:

<u>TARGET RESPONSE</u>	<u>IMPLIED AGREEMENT</u>
(1) REQ/ACK offset less than or equal to the requested value. Minimum Transfer period equal to or greater than than requested period.	REQ/ACK offset equal to target value. Minimum transfer period equal to the target value.
(2) REQ/ACK offset equal to zero.	Asynchronous transfer.
(3) MESSAGE REJECT.	Asynchronous transfer.

12.5.4 continued

If the target recognizes that negotiation is required, it sends a SYNCHRONOUS DATA TRANSFER REQUEST message to the initiator. The REQ/ACK offset is selected to prevent buffer and offset counter overflows, while the minimum transfer period is chosen to meet the data handling requirements of the target. The initiator responds in any of the following ways if the target chooses an REQ/ACK offset equal to FFh:

<u>INITIATOR RESPONSE</u>	<u>IMPLIED AGREEMENT</u>
(1) REQ/ACK offset equal to FFh. Minimum transfer period equal to or greater than requested period.	REQ/ACK offset unlimited. Minimum transfer period equal to the initiator value.
(2) REQ/ACK offset equal to 00h.	Asynchronous transfer. The target may renegotiate for an REQ/ACK offset less than FFh and greater than 00h.
(3) MESSAGE REJECT.	Asynchronous transfer.

The initiator responds in any of the following ways if the target selects an REQ/ACK offset less than FFh:

<u>INITIATOR RESPONSE</u>	<u>IMPLIED AGREEMENT</u>
(1) REQ/ACK offset less than or equal to the requested value. Minimum transfer period equal to or greater than requested value.	REQ/ACK offset equals initiator value. Minimum transfer period equal to the initiator value.
(2) REQ/ACK offset equal to zero.	Asynchronous transfer.
(3) MESSAGE REJECT	Asynchronous transfer.

The implied agreement shall remain in effect until a BUS DEVICE RESET message is received, until a "hard" RESET condition occurs, or until one of the two SCSI devices elects to modify the agreement. Renegotiation at every selection is not recommended, since a significant performance impact is likely. The default mode of data transfer is asynchronous mode. The default mode is entered at power on, after a BUS DEVICE RESET message or after a "hard" RESET condition. The SYNCHRONOUS DATA TRANSFER REQUEST message exchange can only take place following a SELECTION phase that includes the SCSI IDs for both the initiator and the target. Violation of this rule may make data transfer impossible owing to disagreements among SCSI devices about the data transfer mode.

12.5.4 continued

The WREN V will never send a Synchronous Data Transfer request message unless a Initiator sends this message to the WREN V first.

The WREN V will support a REQ/ACK Offset of up to 15.

The WREN V is capable of supporting the following transfer periods.

<u>M (DECIMAL)</u>	<u>TRANSFER PERIOD (M TIMES 4 NANOSECONDS)</u>
53	212
63	252
73	292
84	336
94	376
105	420
115	460
125	500
136	544
146	584
157	628
167	668
178	712
188	752
198	792
209	836
219	876
230	920
240	960
250	1000

13.0 SCSI COMMANDS

This section defines the SCSI command structure and describes a typical SCSI bus procedure involving a command, status return and message interchange. It should be noted that WREN V does not support command linking and will respond with a "Check Condition" status and "Illegal Request" sense key if a linked command is received.

13.0 continued

The command structure defined herein provides for a contiguous set of logical blocks of data to be transferred across the interface. The number of the logical data blocks to be transferred are defined in the command. Initiator commands to the WREN V are structured in accordance with the requirements imposed by the WREN V physical characteristics. These physical characteristics are reported to the initiator in response to an inquiry command.

A single command may transfer one or more logical blocks of data. The WREN V may disconnect from the SCSI bus to allow activity by other SCSI devices while the WREN V performs operations within itself.

Upon command completion (which may be executed either successfully or unsuccessfully), the WREN V returns a status byte to the initiator. Since most error and exception conditions cannot be adequately described with a single status byte, one status code that can be sent as the status byte is called Check Condition. It indicates that additional information is available. The initiator may issue a Request Sense command to request the return of the additional information as part of the Data In phase of the command.

13.1 COMMAND IMPLEMENTATION REQUIREMENTS

The first byte of any SCSI command contains an operation code as defined in this document. Three bits (bits 7 - 5) of the second byte of each SCSI command specify the logical unit if it is not specified using the Identify Message (see Paragraph 12.5.2). Only logic unit zero is valid for the WREN V. The last byte of all SCSI commands shall contain a control byte as defined in Paragraph 13.2.6.

13.1.1 Reserved

Reserved bits, bytes, fields, and code values are set aside for future standardization. Their use and interpretation will be specified by future extensions to this specification. A reserved bit, field, or byte shall be set to zero, or in accordance with a future extension to this specification. A WREN V that receives a reserved code value shall terminate the command with a Check Condition status and the Sense Key shall be set to Illegal Request. It shall also be acceptable for the WREN V to interpret the bit, field, byte, or code value in accordance with a future extension to this specification.

13.1.2 Operation Code Type

Not applicable

13.1.3 Unit Attention Condition

The Unit Attention condition is a state in WREN V operation wherein it must notify each of the devices on the SCSI bus that has an initiator relationship to the WREN V that certain events have occurred. The Unit Attention condition results when one of the following events occur:

1. A power-on sequence occurs.
2. A reset is generated internally by the WREN V (caused by a power glitch).
3. A Bus Device Reset message causes the WREN V to reset itself.
4. The RESET I/O line resets the WREN V.
5. When an initiator changes one or more of the Mode Select parameters in the WREN V (these changes could affect one or more of the other initiators).

The WREN V sets up the Unit Attention condition when it stores (within itself) a Unit Attention condition flag for each device on the SCSI bus having an initiator relationship with the WREN V, and this Unit Attention condition persists for each initiator until the condition is cleared (flag negated) by each initiator individually.

The Unit Attention condition for a particular initiator is cleared when that initiator does one of the following:

1. It sends a Request Sense Command.
2. It sends any other legitimate command, with the exception of the Inquiry command. The Inquiry command does not clear the Unit Attention condition.

When a Unit Attention condition flag is stored in the WREN V for an initiator (say initiator X), the commands initiator X issues to the WREN V operate as described in the following paragraphs.

If initiator X sends an Inquiry command to the WREN V when the WREN V has stored a Unit Attention condition flag for initiator X (before or after the WREN V reports Check Condition status), the WREN V shall perform the Inquiry command and shall not clear the Unit Attention condition.

If initiator X sends a Request Sense command to the WREN V when a Unit Attention condition flag is stored for initiator X (before or after the WREN V reports Check Condition), the WREN V shall discard any pending sense data, report the Unit Attention Sense Key, and clear the Unit Attention condition (negate the flag) for initiator X.

13.1.3 (continued)

If initiator X issues a command other than Inquiry or Request Sense while a Unit Attention condition flag is stored for initiator X, the WREN V shall not perform the command and shall report Check Condition status. If a Request Sense is issued next, the Unit Attention condition will be reported and cleared (flag negated) as noted in the preceding paragraph. If another command other than Request Sense or Inquiry is issued instead, the WREN V shall perform the command and return the appropriate status. The Unit Attention condition for initiator X is cleared (flag negated) and the sense data and flag indicating there has been a Unit Attention condition are lost.

13.1.4 Command Queuing

The WREN V is capable of accepting and queuing one command from each initiator for up to 7 possible initiators. When commands are queued, after the WREN V is selected it will accept the command bytes, send a Disconnect message, go to Bus Free phase, and continue command execution. If the command cannot be queued, the WREN V will allow itself to be selected and will accept the command bytes for this command. The WREN V will then go to the status phase and send Busy Status back to the initiator.

Command queuing can be done only for initiators that support Arbitration and Reselection phases, send an Identify message after Selection, and allow disconnection. Initiators that don't support these options will be handled as follows:

In this case or if the command queue is full, the WREN V will allow itself to be selected and will accept the command bytes for a new command. It will then go to the Status phase and send Busy status to the initiator (see Section 14.0). After a Command Complete message and going to Bus Free phase, the WREN V will resume execution of its current command. An initiator that received Busy status in this manner will have to resend the command later in order to have it executed.

A WREN V will not queue Reserve commands because of the special considerations involved with queuing these commands. See the sections describing the Reserve command for further details.

All commands that are queued will eventually be executed in accordance with the WREN V priority scheme unless a hard Reset, a Power On Reset, or a Bus Device Reset message is received. In these cases, all queued commands will be cleared and no status will be sent to the initiator.

13.2 COMMAND DESCRIPTOR BLOCK (CDB)

A request by an initiator to a WREN V is performed by sending a Command Descriptor Block (CDB) to the WREN V. For several commands, the request is accompanied by a list of parameters sent during the Data Out phase. See the specific commands for detailed information.

The Command Descriptor Block always has an operation code as the first byte of the command. This is followed by a logical unit number, command parameters (if any), and a control byte.

For all commands, if there is an invalid parameter in the Command Descriptor Block, the WREN V shall terminate the command without altering the medium.

The Format description for the Command Descriptor Block as supported by the WREN V is shown in Tables 13.2-1, 13.2-2 and 13.2-3.

13.2.1 Operation Code

The operation code (Table 13.2-1) of the Command descriptor Block has a group code field and a command code field. The three bit group code field provides for eight groups of command codes. The five bit command code field provides for thirty two command codes in each group. Thus, a total of 256 possible operation codes exist. Operation codes are defined in Section 14.

For the WREN V the group code specifies one of the following groups:

- Group 0 - Six byte commands (see Table 13.2-2).
- Group 1 - Ten byte commands (see Table 13.2-3).

TABLE 13.2-1. OPERATION CODE FORMAT FOR CDB

BIT	7	6	5	4	3	2	1	0
BYTE(S)								
0	Group Code			Command Code				

TABLE 13.2-2. TYPICAL COMMAND DESCRIPTOR BLOCK FOR SIX BYTE COMMANDS

BIT	7	6	5	4	3	2	1	0
BYTE(S)								
0	Operation Code							
1	Logical Unit No. 0 0 0			Logical Block Address (if req.) (MSB)				
2	Logical Block Address (if required)							
3	Logical Block Address (if required) (LSB)							
4	Transfer Length (if required)							
5	Control Byte							

TABLE 13.2-3. TYPICAL COMMAND DESCRIPTOR BLOCK FOR TEN BYTE COMMANDS

BIT	7	6	5	4	3	2	1	0
BYTE(S)								
0	Operation Code							
1	Logical Unit No. 0 0 0			Reserved			RelAdr 0	
2	Logical Block Address (if required) (MSB)							
3	Logical Block Address (if required)							
4	Logical Block Address (if required)							
5	Logical Block Address (if required) (LSB)							
6	Reserved							
7	Transfer Length (if required) (MSB)							
8	Transfer Length (if required) (LSB)							
9	Control Byte							

13.2.2 Logical Unit Number (LUN)

The logical unit number (LUN) addresses one of up to eight physical devices or virtual devices attached to a target. The only valid LUN number for WREN V is Zero.

The LUN in the CDB is provided for systems that do not implement the Identify Message. If an Identify message is sent to the WREN V, the WREN V will use the LUN number specified in this message. In this case, the WREN V shall ignore the LUN specified within the command descriptor block.

The WREN V will reject commands which select an invalid LUN (except Request Sense and Inquiry) by requesting and accepting the command bytes, then going to Status phase and sending Check Condition status. Note that the LUN is sent in the LUN field of a CDB (if no Identify message has been received for this selection) or by the LUN field of an Identify message.

Request Sense commands selecting an invalid LUN will receive a Sense Data block with the Illegal Request Sense Key and an Invalid LUN Error Code. Inquiry commands will return Inquiry Data with the Peripheral Device Type field set to Logical Unit Not Present (7FH). Request Sense and Inquiry commands will not send Check Condition status in response to an invalid LUN selection.

13.2.3 Logical Block Address

The logical block address on logical units shall begin with block zero and be contiguous up to the last logical block on that logical unit.

Group 0 command descriptor block contain 21 bit logical block addresses. Group 1 command descriptor blocks contain 32 bit logical block addresses.

The logical block concept implies that the initiator and target shall have previously established the number of data bytes per logical block. This may be established through the use of the Read Capacity command or the Mode Sense command or by prior arrangement.

The maximum logical block address for WREN V which is accessible by the Initiator is defined in Read Capacity Data in section 14.2.2.1.

13.2.4 Relative Address Bit

Not implemented. Must be zero.

13.2.5 Transfer Length

The Transfer Length specifies the amount of data to be transferred, usually the number of blocks. For several commands the transfer length indicates the requested number of bytes to be sent as defined in the command description. For these commands the transfer length field may be identified by a different name. See the following descriptions and the individual command descriptions for further information.

Commands that use one byte for Transfer Length allow up to 256 blocks of data to be transferred by one command. A Transfer Length value of 1 to 255 indicates the number of blocks that shall be transferred. A value of zero indicates 256 blocks.

Commands that use two bytes for Transfer Length allow up to 65,535 blocks of data to be transferred by one command. In this case, a Transfer Length of zero indicates that no data transfer shall take place. A value of 1 to 65,535 indicates the number of blocks that shall be transferred.

For several commands more than two bytes are allocated for Transfer Length. Refer to the specific command description for further information.

The Transfer Length of the commands that are used to send a list of parameters to a WREN V is called the Parameter List Length. The Parameter List Length specifies the number of bytes sent during the Data Out phase.

The Transfer Length of the commands used to return sense data (e.g. Request Sense, Inquiry, Mode Sense, etc) to an initiator is called the Allocation Length. The Allocation Length specifies the number of bytes that the initiator has allocated for returned data. The WREN V shall terminate the Data In phase when Allocation Length bytes have been transferred or when all available data have been transferred to the initiator, whichever is less. The Request Sense command is an exception. An Allocation Length of zero indicates four bytes are to be transferred, not zero. See Mode Sense and Mode Select commands.

13.2.6 Control Byte

Must be all zeros. WREN V does not support the Flag and Link bit functions. These bits must be zero for the command to be accepted. If not, WREN V will send a "Check Condition" Status and a Sense Key of "Illegal Request". See Table 13.2.6-1.

TABLE 13.2.6-1. CONTROL BYTE
(Table 6-4 in CDC SCSI Spec)

BIT	7	6	5	4	3	2	1	0
BYTE(S)							FLAG	LINK
LAST	0	0	0	0	0	0	0	0

13.3 COMMAND EXAMPLES

13.3.1 Single Command Example

A typical operation on the SCSI bus is likely to include a single Read command to a peripheral device such as the WREN V. This operation is described in detail starting with a request from the initiator. This example assumes that no malfunctions or errors occur and is illustrated in Figure 13.3-1.

The initiator has active pointers and a set of stored pointers representing active disconnected SCSI devices (an initiator without disconnect capability does not require stored pointers). The initiator sets up the active pointers for the operation requested, arbitrates for the SCSI bus, and selects the WREN V. Once this process is completed, the WREN V assumes control of the operation.

The WREN V obtains the command from the initiator (in this case, a Read command). The WREN V interprets the command and executes it. For this command, the WREN V reads the requested data from the Disk Media and sends this data to the initiator. After sending the read data to the initiator, the WREN V sends a status byte to the initiator. To end the operation, the WREN V sends a Command Complete message to the initiator and then goes to the Bus Free state.

13.3.1 (continued)

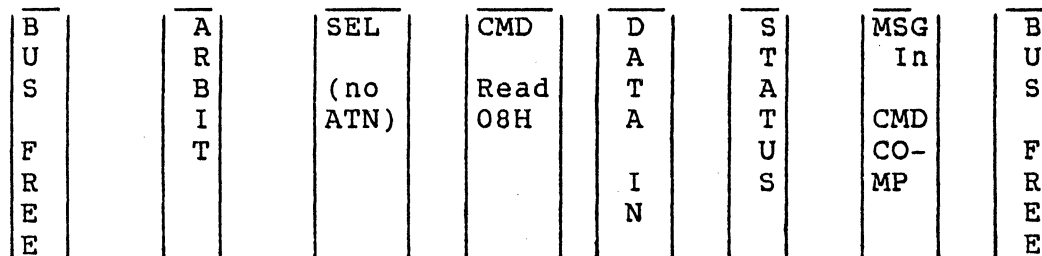

FIGURE 13.3-1. SINGLE COMMAND EXAMPLE

13.3.2 Disconnect Example

In the single command example, the length of time necessary to obtain the data may require a time consuming physical seek. In order to improve system throughput, the WREN V may disconnect from the initiator, freeing the SCSI bus to allow other requests to be sent to other SCSI devices. To do this, the initiator must be reselectable and capable of restoring the pointers upon reconnection. The WREN V must be capable of arbitrating for the SCSI bus and reselecting the initiator. See Figure 13.3-2.

After the WREN V has received the Read command (and has determined that there will be a delay), it disconnects by sending a Disconnect message and releasing BSY (goes to BUS Free state).

When the data is ready to be transferred, the WREN V reconnects to the initiator, the initiator restores the pointers to their most recently saved values (which, in this case, are the initial values) and the WREN V continues (as in the single command example) to finish the operation. The initiator recognizes that the operation is complete when a Command Complete message is received.

If the WREN V wishes to disconnect after transferring part of the data (e.g. while crossing a cylinder boundary), it may do so by sending a Save Data Pointer message and a Disconnect message to the initiator and then disconnecting. When reconnection is completed, the current data pointer is restored to its value immediately before the Save Data Pointer message.

On those occasions when an error or exception condition occurs and the WREN V elects to repeat the information transfer, the WREN V may repeat the transfer by issuing a Restore Pointers message or by disconnecting without issuing a Save Data Pointer message. When reconnection is completed, the most recently saved pointer values are restored.

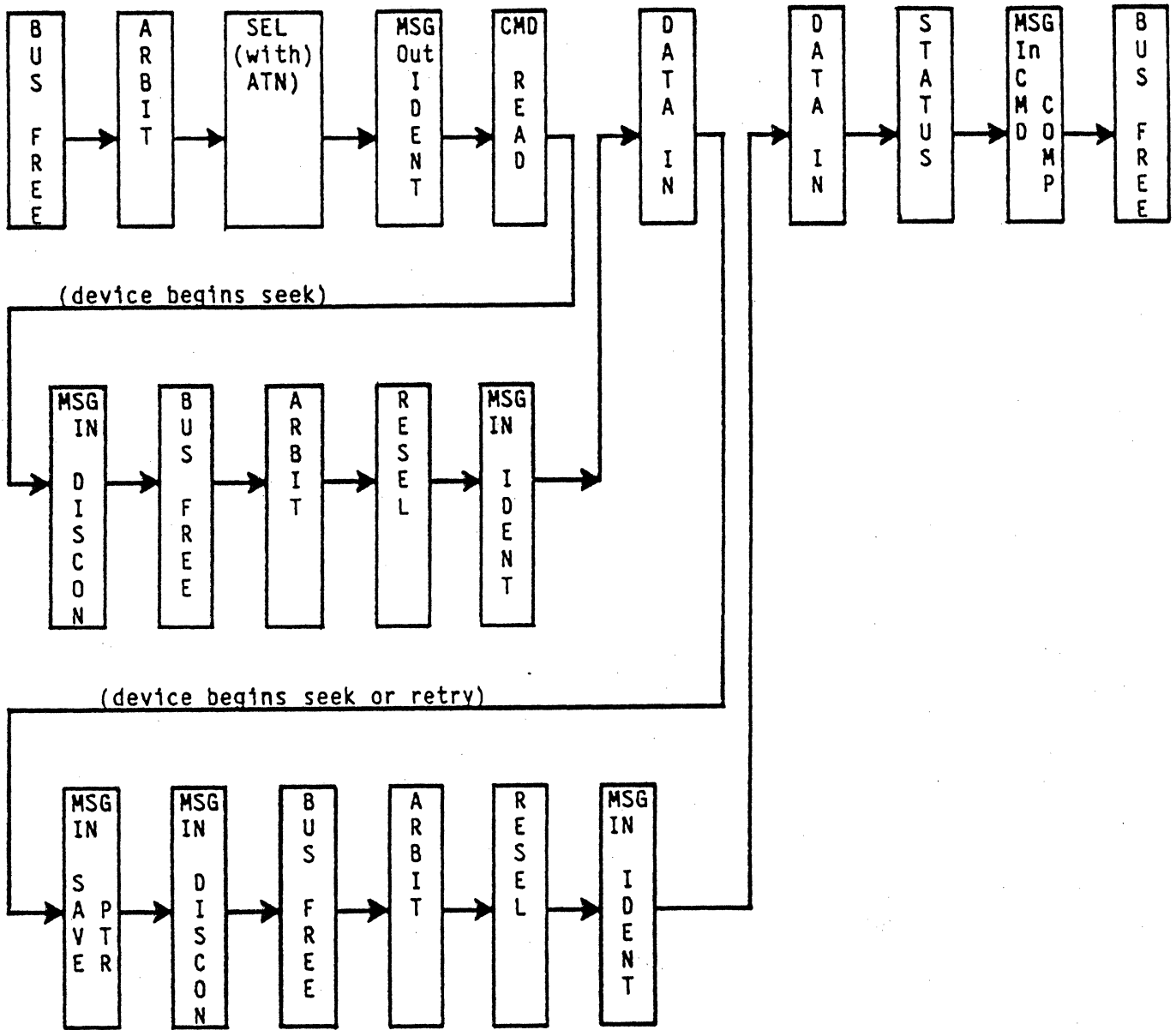

FIGURE 13.3-2. DISCONNECT EXAMPLE

13.4 TIMING EXAMPLES

Times (T00 through T35) necessary to define performance are listed in Table 13.5-1. Timing waveforms to define these times are illustrated in Tables 13.4-1 through 13.4-15.

TABLE 13.4-1. ARBITRATION, SELECTION (NO ATN), AND COMMAND PHASE

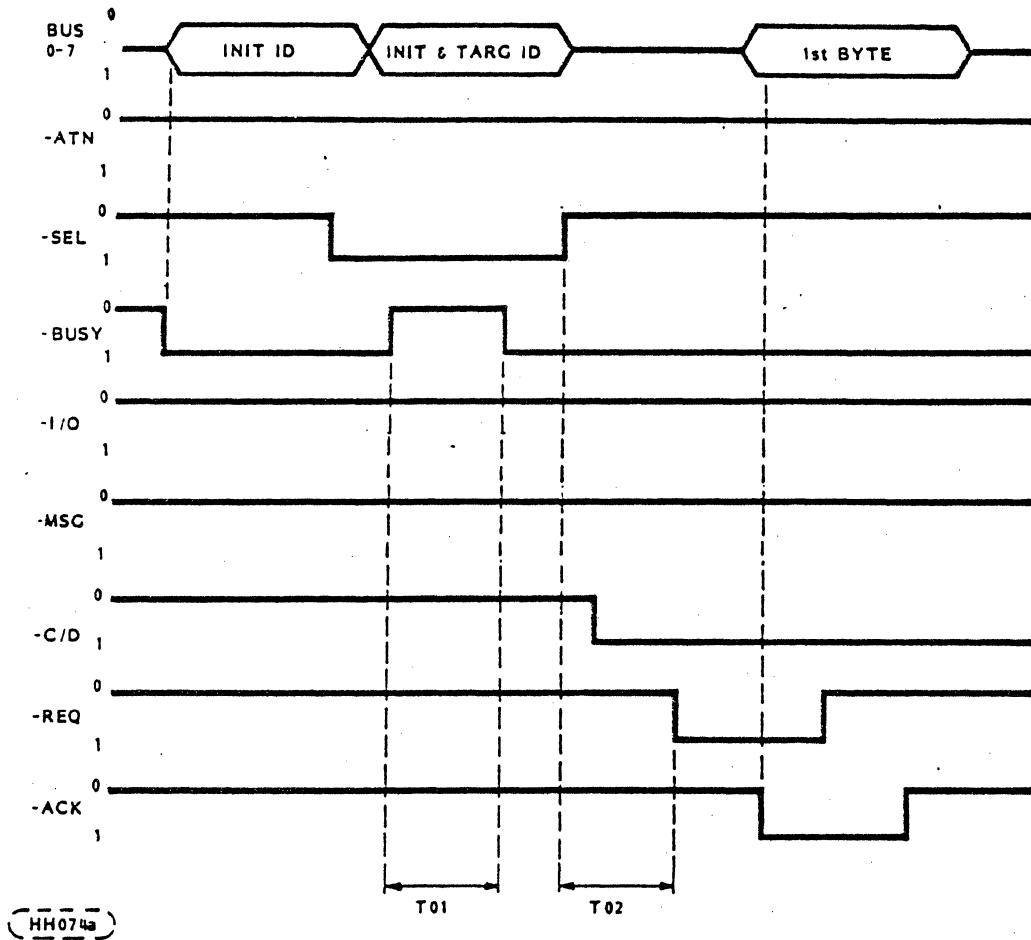

TABLE 13.4-2. ARBITRATION, SELECTION (WITH ATN), AND MESSAGE OUT

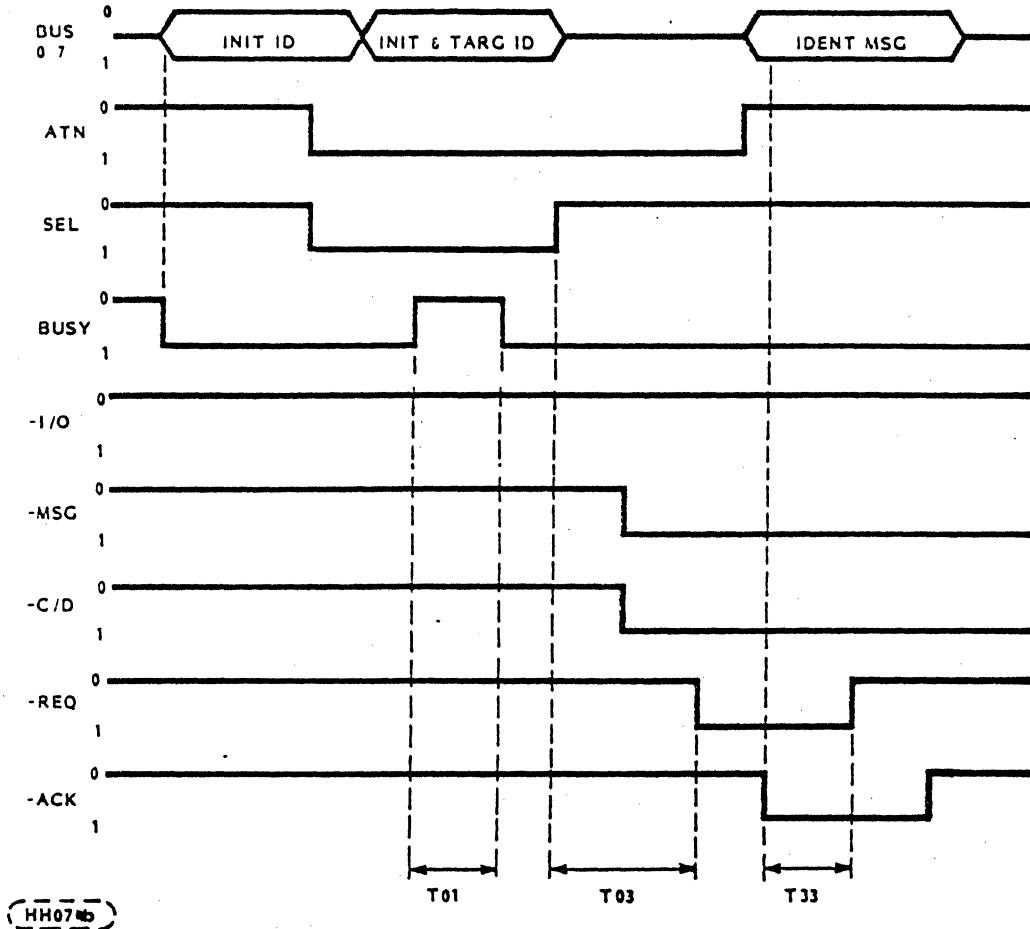

TABLE 13.4-3. IDENTIFY MSG OUT TO COMMAND PHASE

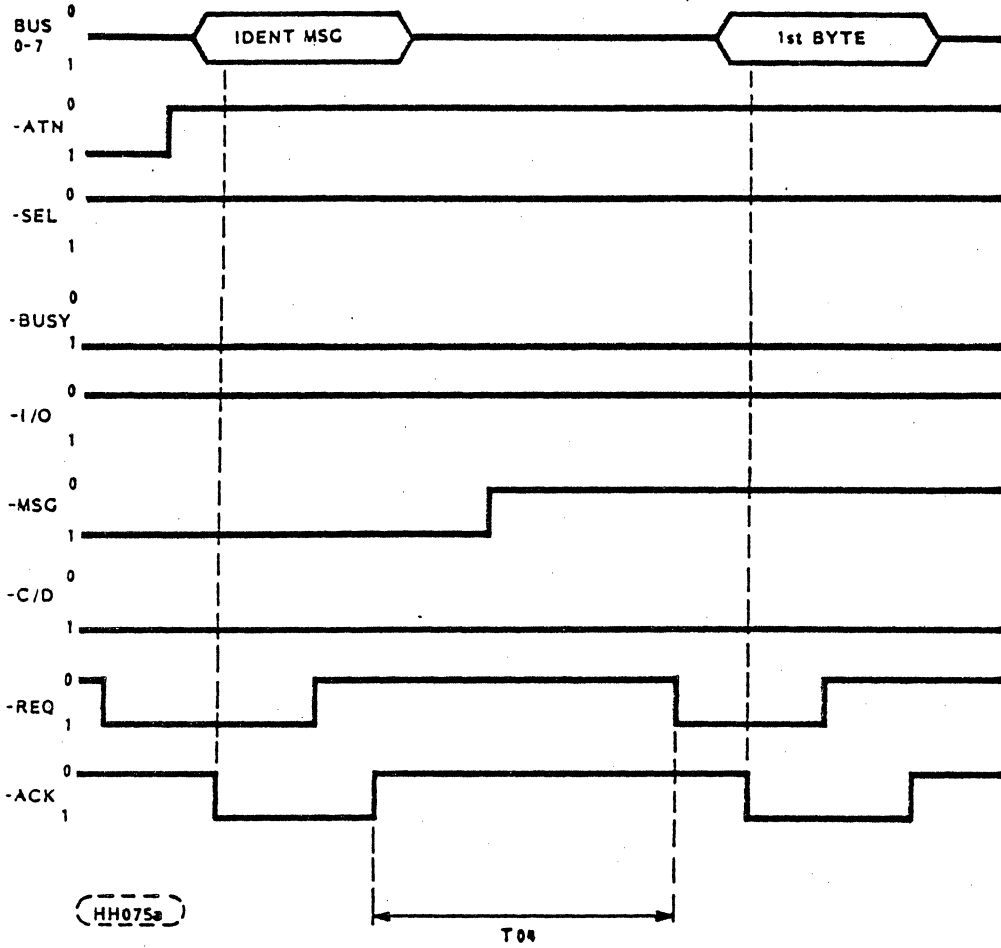

TABLE 13.4-4. COMMAND DESCRIPTOR BLOCK TRANSFER

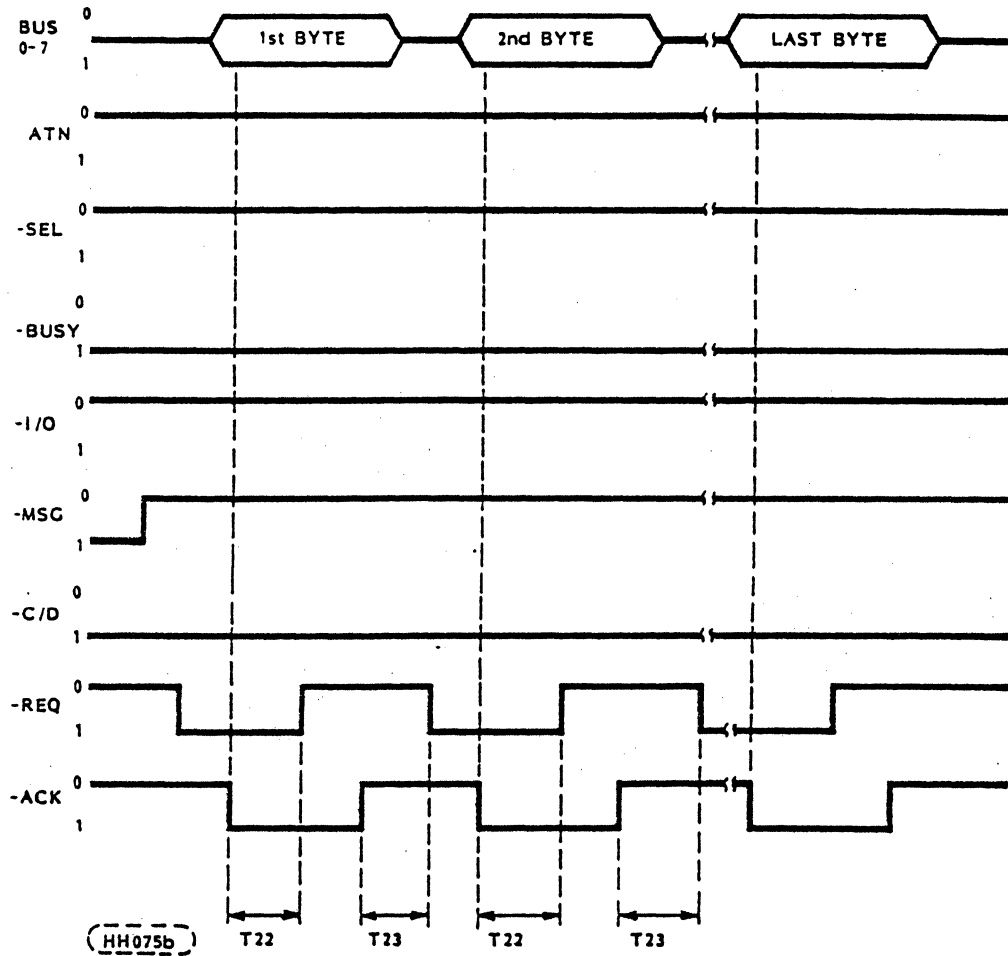

TABLE 13.4-5. COMMAND PHASE, STATUS PHASE, COMMAND COMPLETE MSG AND BUS FREE

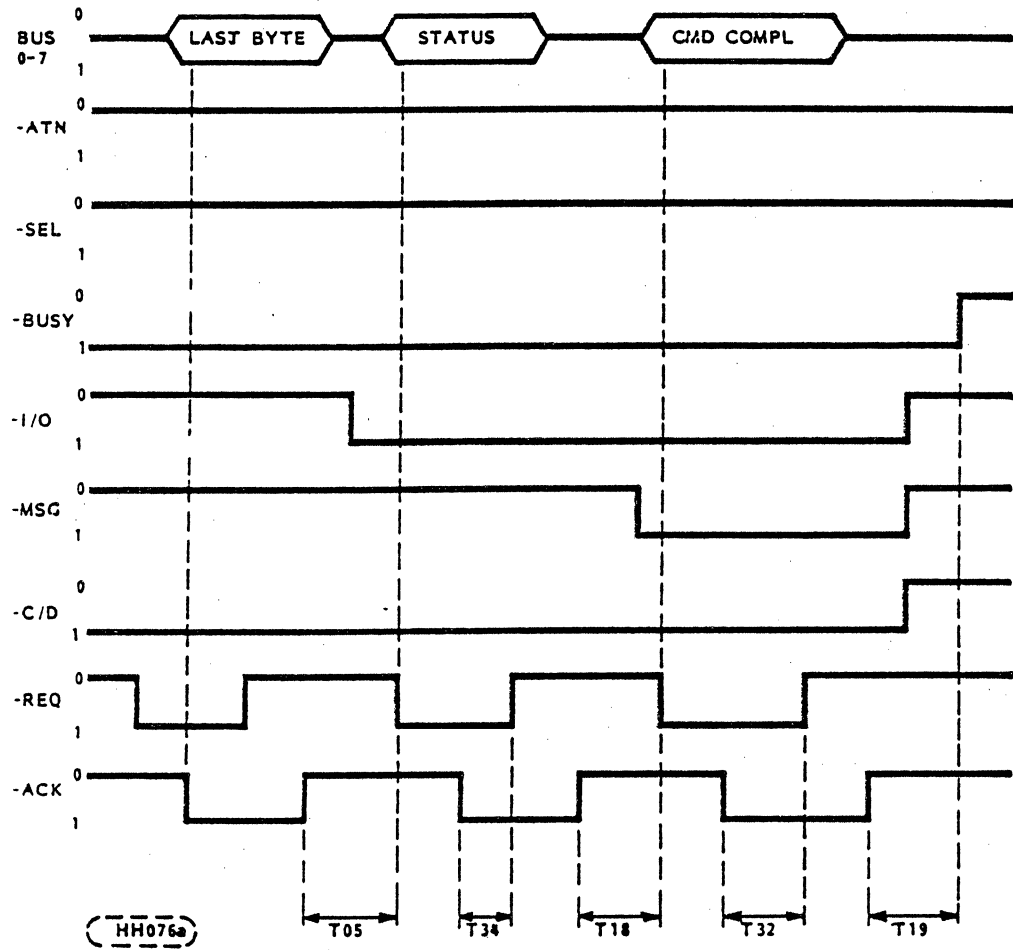
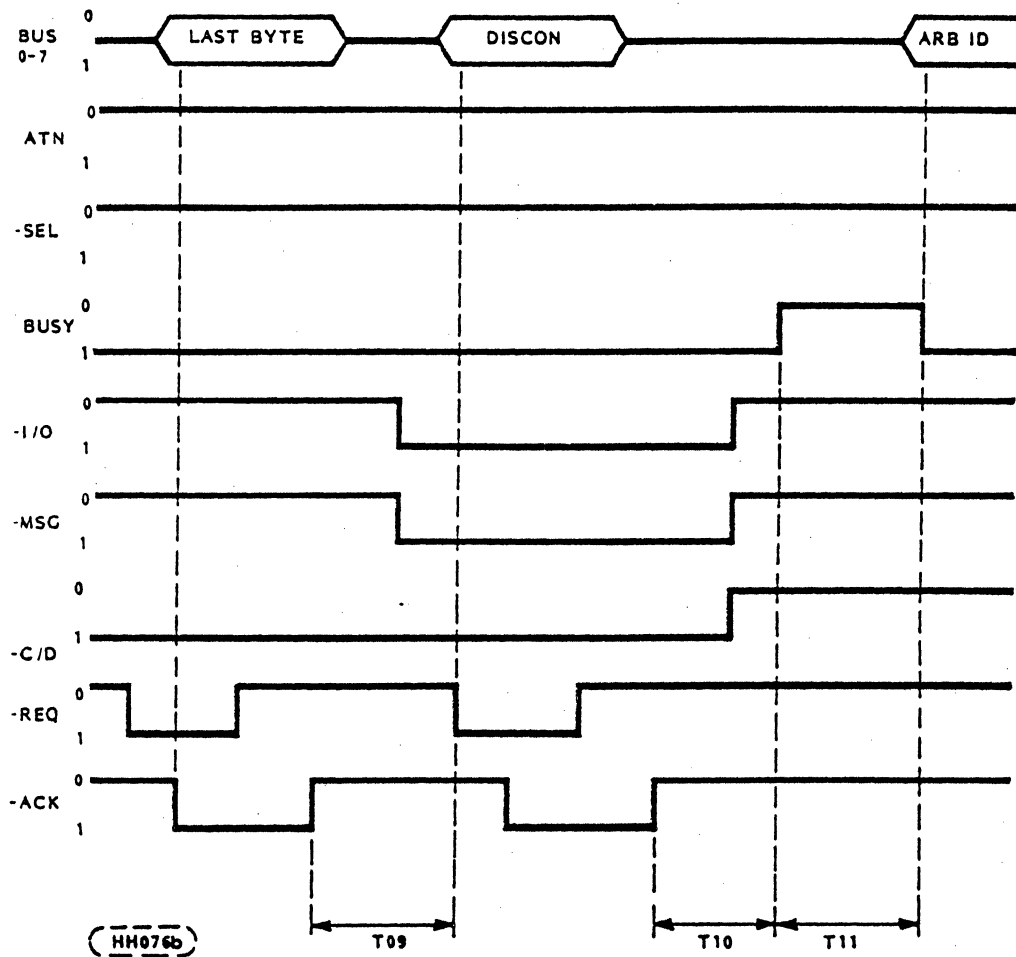

TABLE 13.4-6. LAST COMMAND BYTE, DISCONNECT MSG, BUS FREE, AND RESELECT



NOTE: To measure T11, there must be no other device contending for the SCSI BUS.

TABLE 13.4-7. ARBITRATION, RESELECTION AND MESSAGE IN

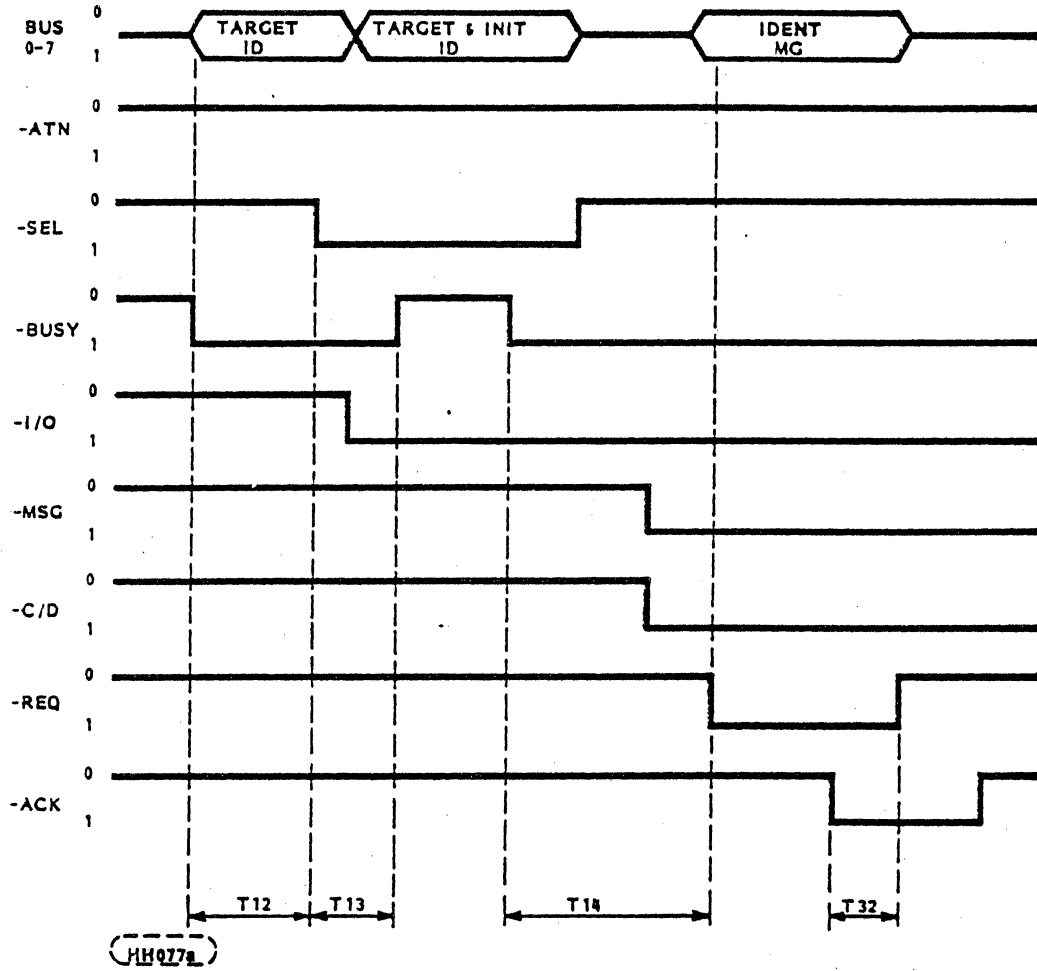

TABLE 13.4-8. RESELECT IDENTIFY MSG, STATUS PHASE, COMMAND COMPLETE MSG AND BUS FREE

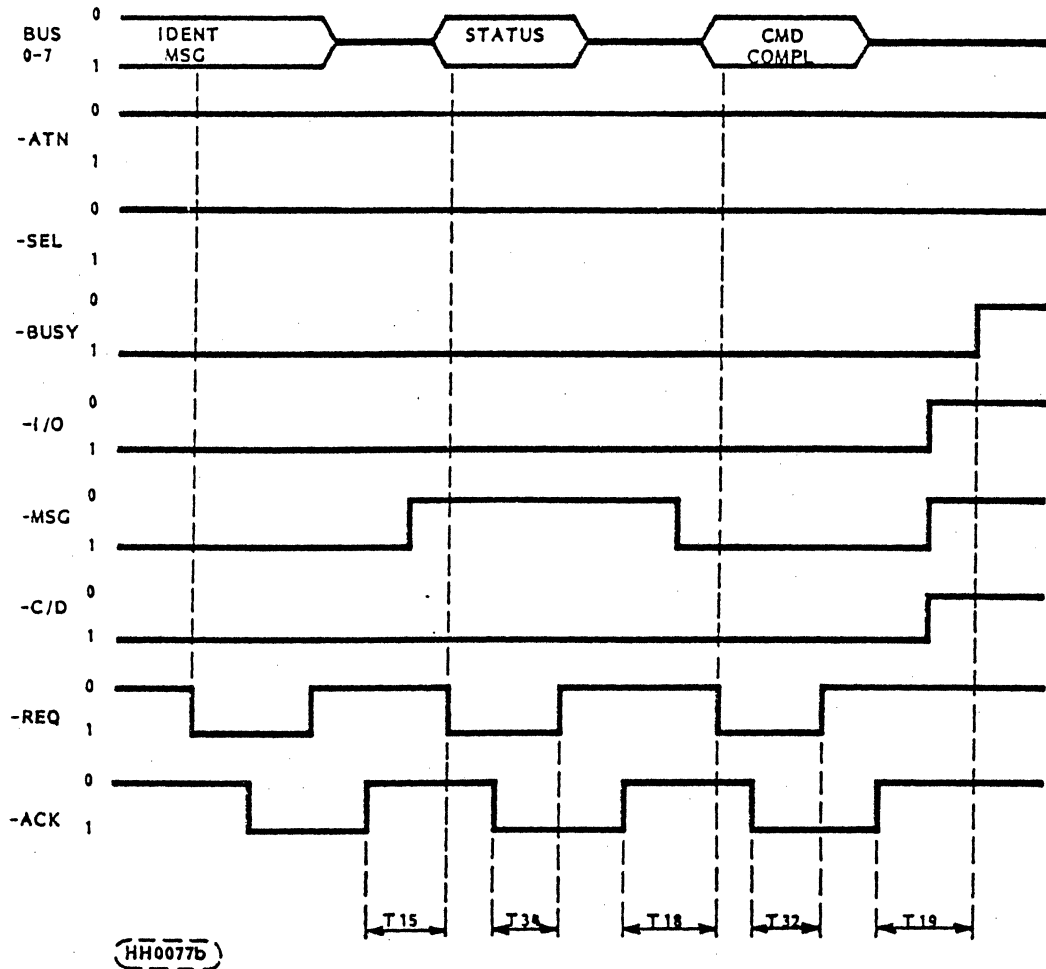

TABLE 13.4-9. LAST COMMAND BYTE TO DATA IN PHASE

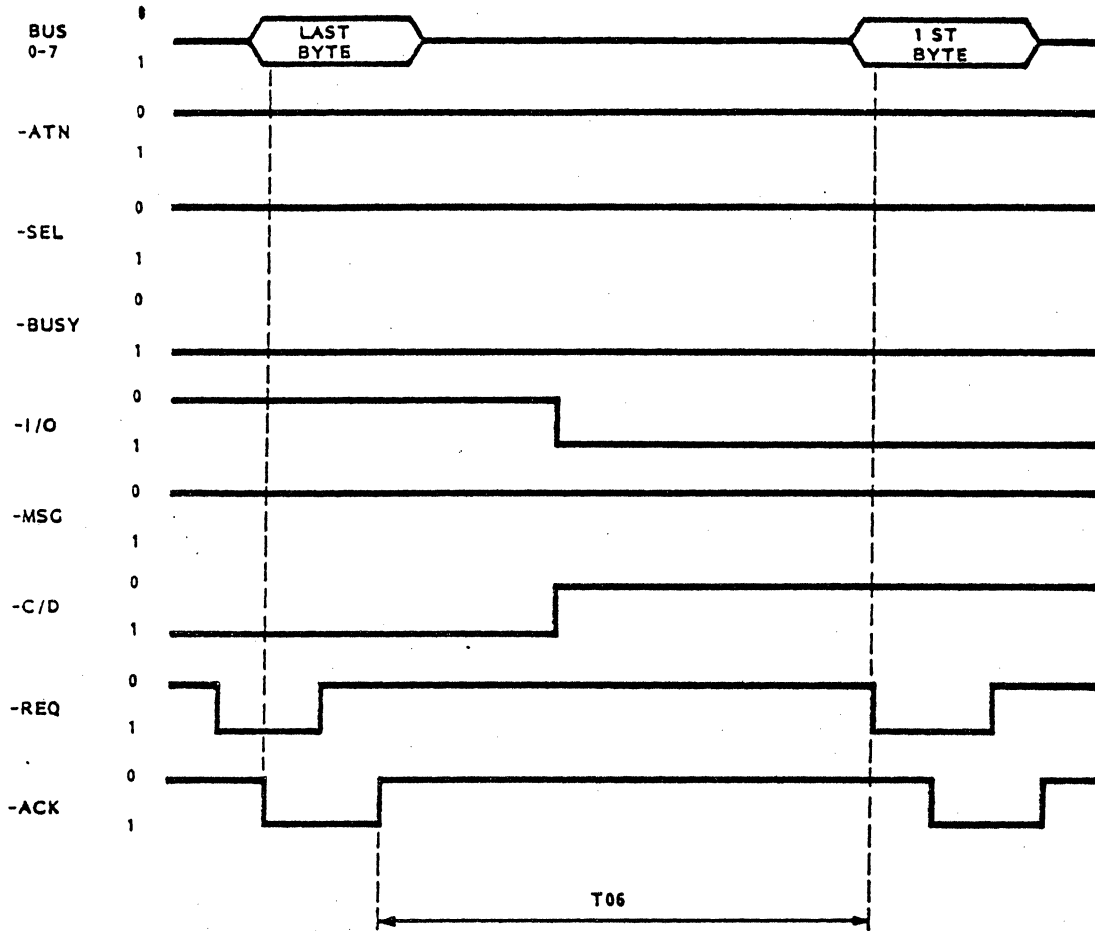

TABLE 13.4-10. LAST COMMAND BYTE TO DATA OUT PHASE

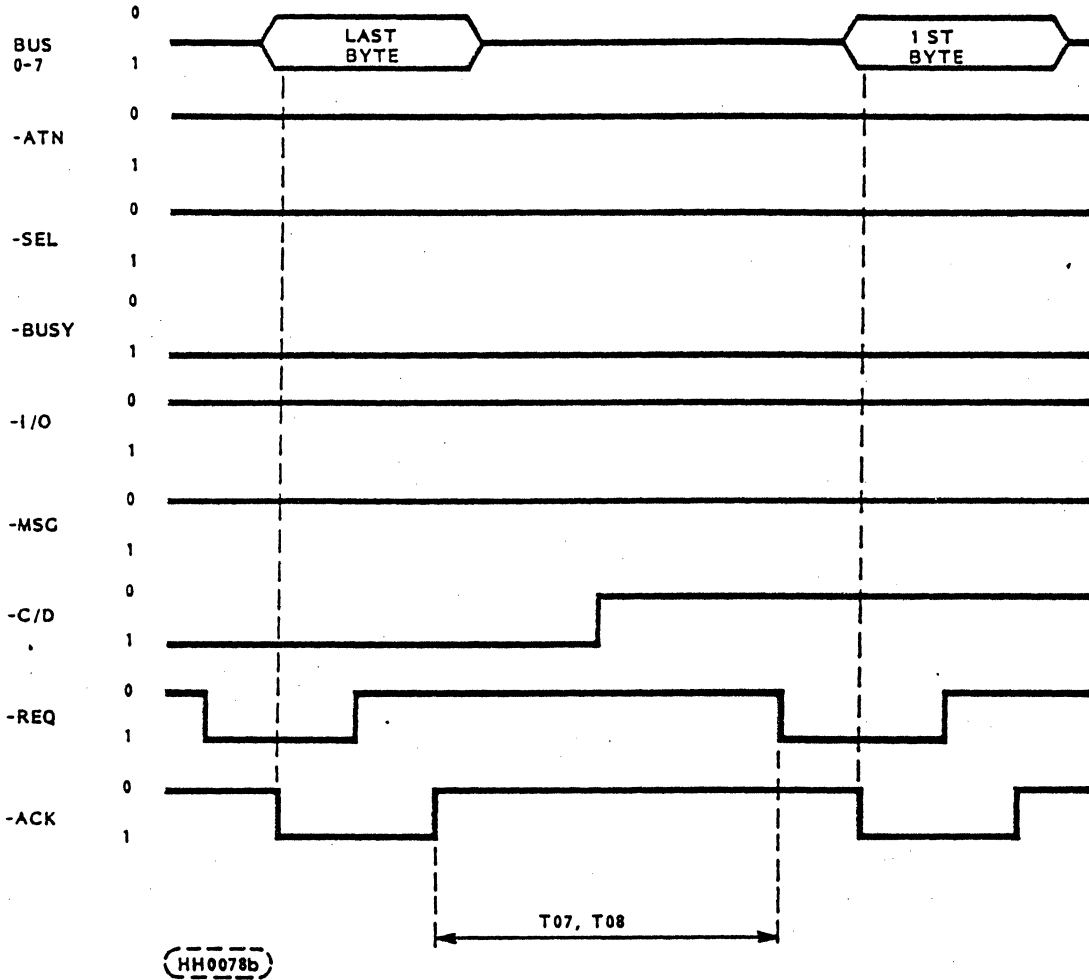
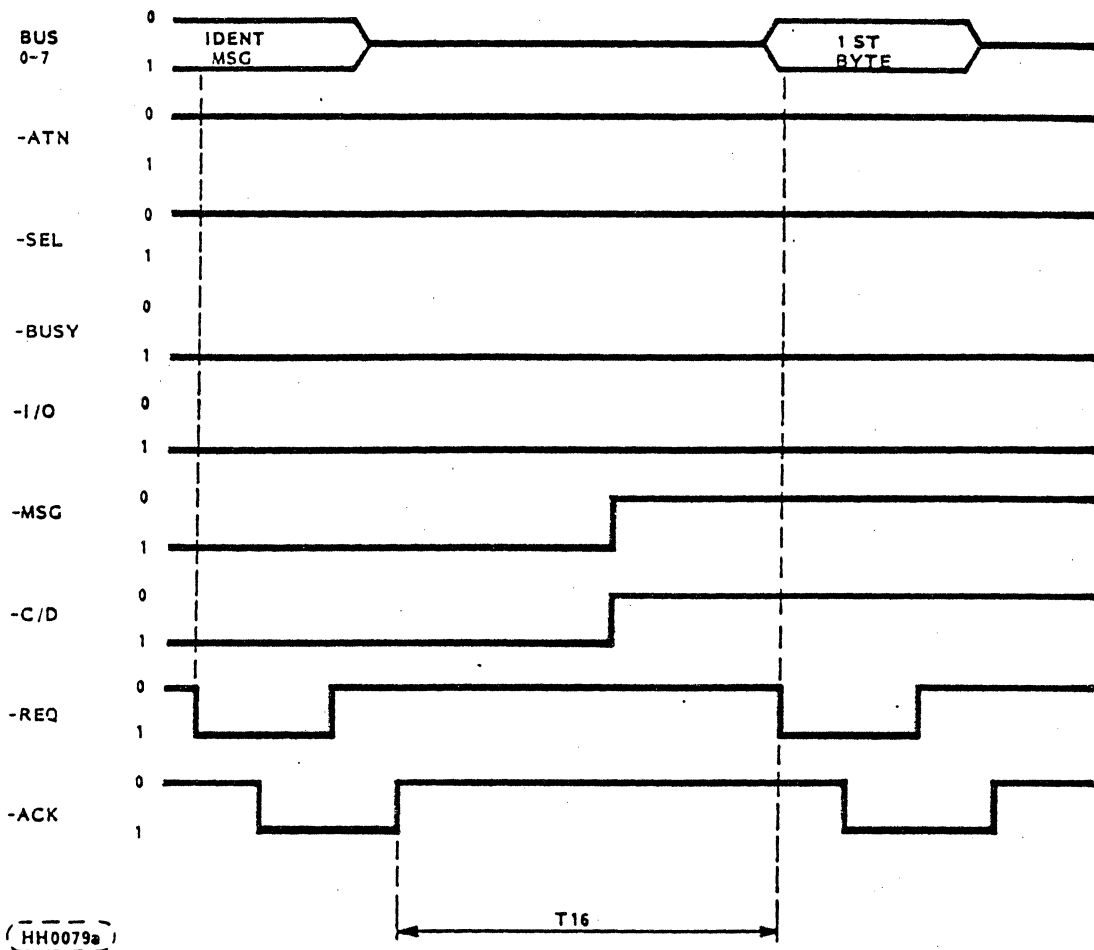

TABLE 13.4-11. RESELECT IDENTIFY MSG TO DATA IN PHASE



(HH0079a)

TABLE 13.4-12. DATA IN BLOCK TRANSFER

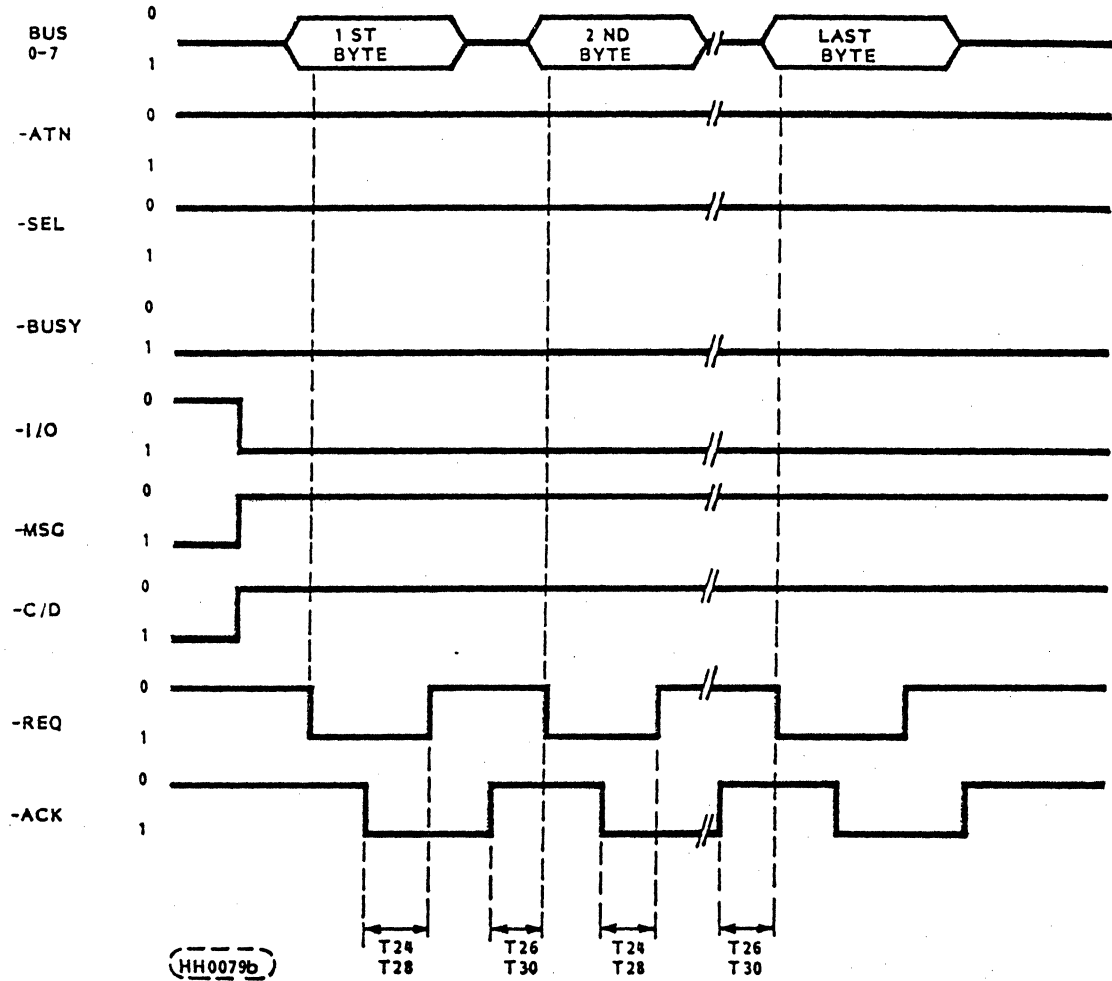

TABLE 13.4-13. DATA OUT BLOCK TRANSFER

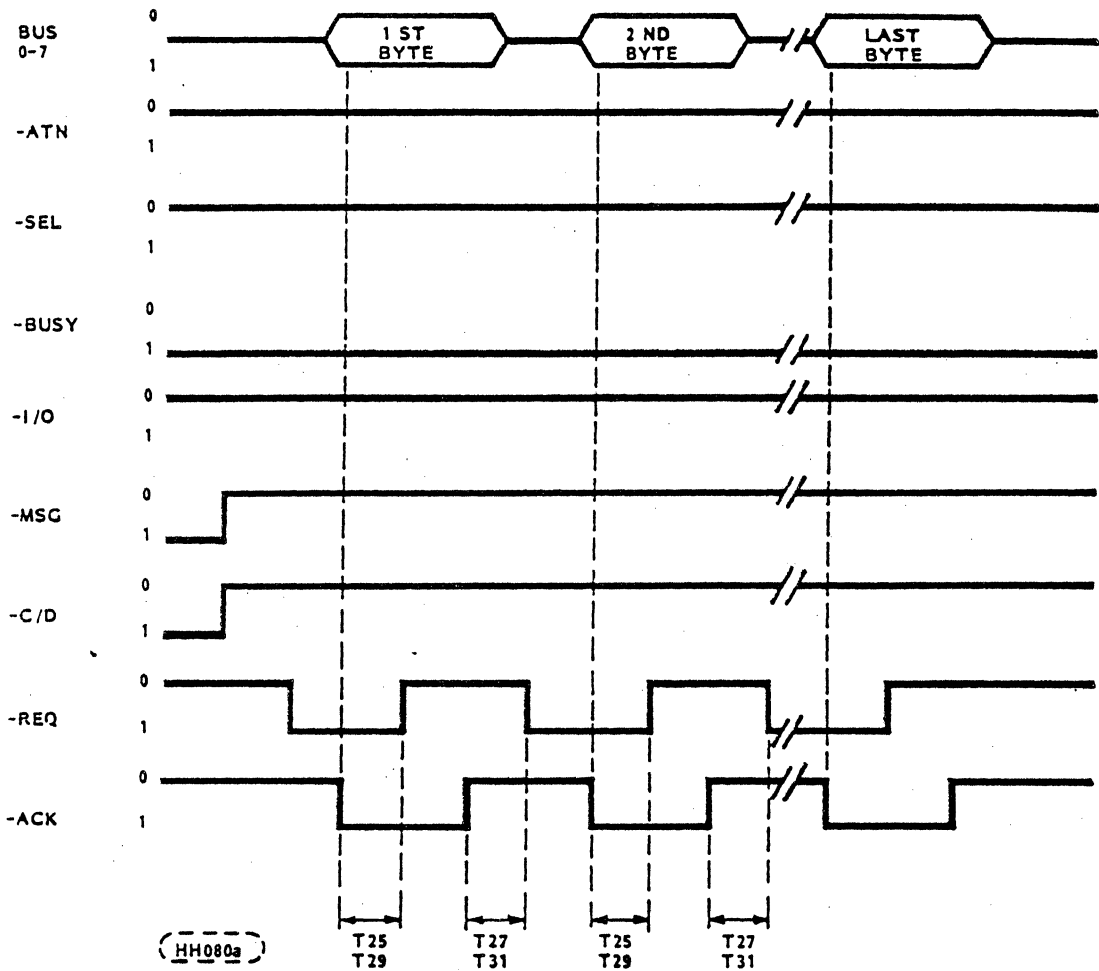

TABLE 13.4-14. LAST DATA BYTE, SAVE POINTER MSG, AND DISCONNECT MSG

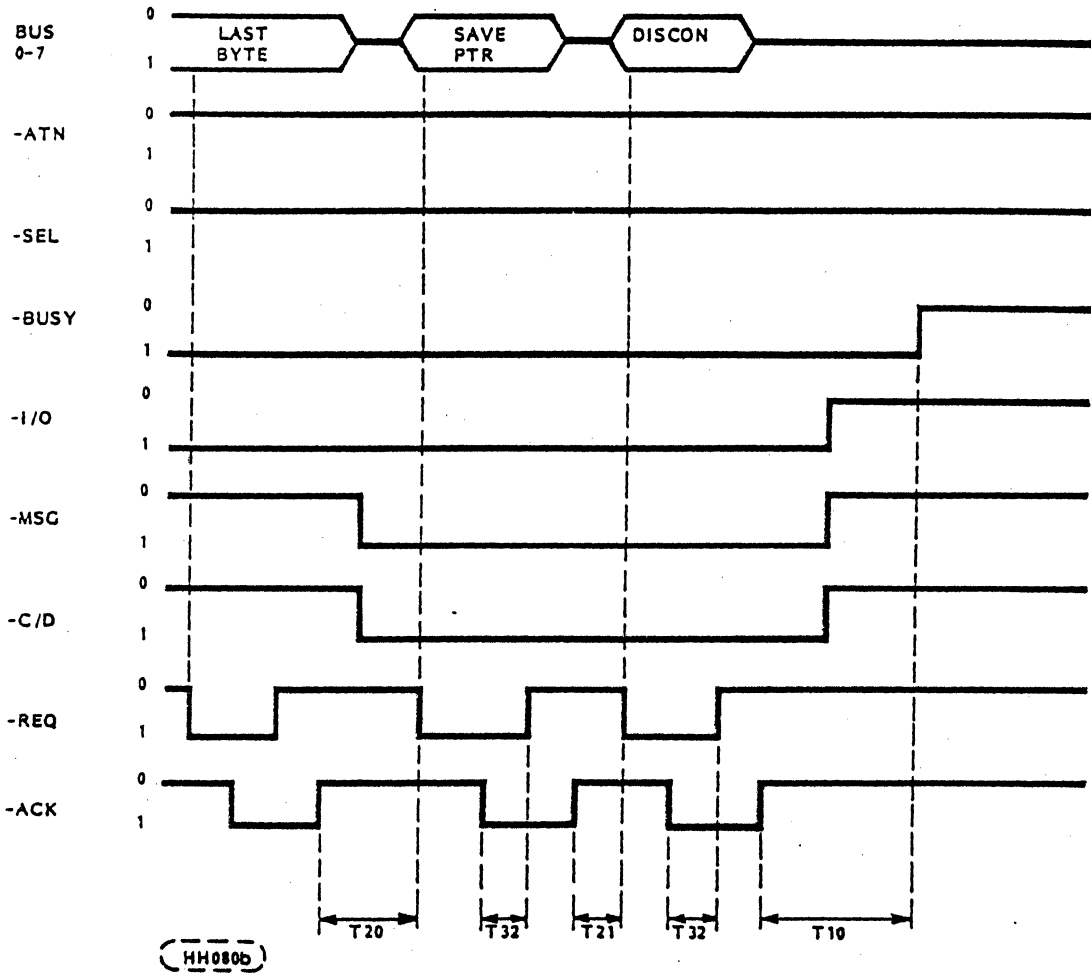
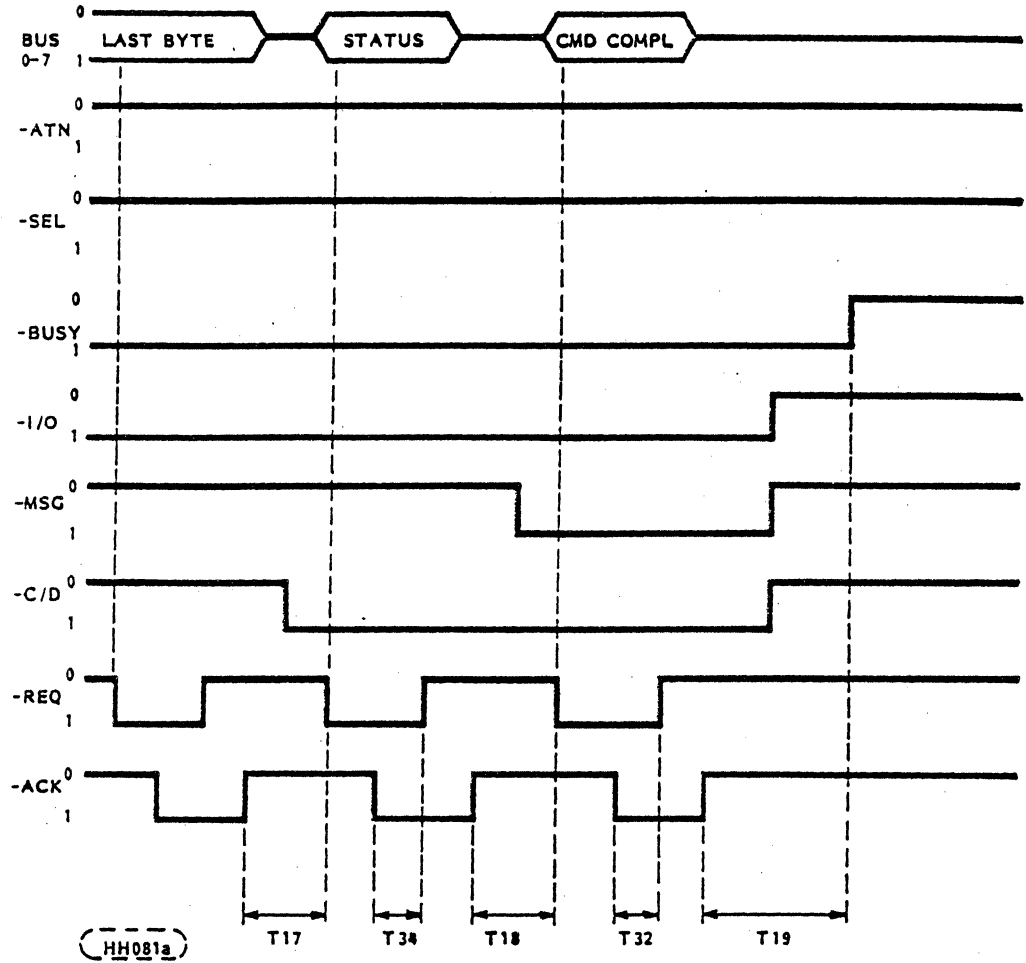

TABLE 13.4-15. DATA IN PHASE, STATUS PHASE, COMMAND COMPLETE MSG, AND BUS FREE



13.5 WREN V SCSI TIMING

TABLE 13.5-1. WREN V SCSI TIMING

<u>DESCRIPTION</u>	<u>WAVEFORM SYMBOL</u>	<u>WAVEFORM TABLE</u>	<u>TYPICAL</u>	<u>MAX</u>
Target Select Time (no Arbitration)	T00	N/A	<1 us	<250 us
Target Select Time (with Arbitration)	T01	13.4-1 13.4-2	<1 us	<250 us
Target Select to Command	T02	13.4-1	<1 us	
Target Select to MSG Out	T03	13.4-2	<1 us	
Identify MSG To Command	T04	13.4-3	<1 us	
Command to Status	T05	13.4-5	Command Dependent	
Command to Data (para. In)	T06	13.4-9	Command Dependent	
Command to Data (para. Out)	T07	13.4-10	Command Dependent	
Command to Data (Write to Data Buffer)	T08	13.4-10	<400 us	600 us
Command to Disconnect MSG	T09	13.4-6	Command Dependent	
Disconnect MSG to Bus Free	T10	13.4-6, 13.4-14	<1 us	
Disconnect to Arbitration (for Reselect) This measures disconnected CMD overhead.	T11	13.4-6	Command Dependent	
Target win Arbitration (for Reselect)	T12	13.4-7	<5 us	
Arbitration to Reselect	T13	13.4-7	<4 us	
Reselect to Identify MSG In	T14	13.4-7	<2 us	
Reselect Identify MSG to Status	T15	13.4-8	<100 us	
Reselect Identify MSG to Data (media)	T16	13.4-11	Command Dependent	
Data to Status	T17	13.4-15	Command Dependent	
Status to Command Complete MSG	T18	13.4-5,8,15	<1 us	
Command Complete MSG to Bus Free	T19	13.4-5,8,15	<1 us	
Data to Save Data Pointer MSG	T20	13.4-14	<175 us	
Save Data Pointer MSG to Disconnect MSG	T21	13.4-14	<2 us	
Command Byte Transfer	T22	13.4-4	<0.06 us	0.1 us
Next Command Byte Access	T23	13.4-4	<0.7 us	1.0 us

Asynchronous Data Transfer Characteristics:

Data In Byte Transfer (parameter)	T24	13.4-12	<0.06 us	0.1 us
Data Out Byte Transfer (parameter)	T25	13.4-13	<0.06 us	0.1 us
Next Data In Byte Access (parameter)	T26	13.4-12	<0.7 us	1.0 us

TABLE 13.5-1. WREN V SCSI TIMING (continued)

<u>DESCRIPTION</u>	<u>WAVEFORM SYMBOL</u>	<u>WAVEFORM TABLE</u>	<u>TYPICAL</u>	<u>MAX</u>
Asynchronous Data Transfer Characteristics: (continued)				
Next Data Out Byte Access (Parameter)	T27	13.4-13	<0.7 us	1.0 us
Data In Byte Transfer (media)[1]	T28	13.4-12	<60 ns	100 ns
Data Out Byte Transfer (media)[1]	T29	13.4-13	<60 ns	100 ns
Next Data In Byte access (media)[1]	T30	13.4-12	<700 ns	1.0 us
Next Data Out Byte access (media)[1]	T31	13.4-13	<700 ns	1.0 us
MSG IN Byte Transfer	T32	13.4-5,7 13.4-8,14,15	<0.06 us	0.1 us
MSG OUT Byte Transfer	T33	13.4-2	<0.06 us	0.1 us
STATUS Byte Transfer	T34	13.4-5,8 13.4-15	<0.06 us	0.1 us

*Synchronous Data Transfer Characteristics:

Request Signal Transfer Period [2] - - - 1.0 us

[1] Maximum SCSI asynchronous interface transfer rate is 2.0 MB/second. Therefore, the, minimum time between two leading edges of Request is 500 ns.

[2] Synchronous Transfer Period is determined by negotiations between an Initiator and a Drive. The Drive is capable of setting periods between 212 ns and 1000 ns in 40 to 44 ns increments. See also section 12.1.5.4.

*Subject to change.

14.0 COMMAND DESCRIPTIONS

Two types of commands are supported by the WREN V: commands for all devices; and commands for direct access devices. In each of these categories the WREN V supports only Group 0 and Group 1 commands.

14.1 COMMAND DESCRIPTIONS FOR ALL DEVICE TYPES

14.1.1 Group 0 Commands for All Device Types

The WREN V implements the following Group 0 commands which are applicable for all device types. See Table 14.1.1-1.

TABLE 14.1.1-1. GROUP 0 COMMANDS FOR ALL DEVICE TYPES

<u>COMMAND OP CODE*</u>	<u>COMMAND NAME</u>	<u>APPLICABLE SECTION</u>
00H	Test Unit Ready	14.1.1.1
03H	Request Sense	14.1.1.2
12H	Inquiry	14.1.1.3
1CH	Receive Diag. Results	14.1.1.5
1DH	Send Diagnostic	14.1.1.6

*Byte 0 of Command Descriptor Block.

14.1.1.1 Test Unit Ready (00H)

TABLE 14.1.1-2. TEST UNIT READY COMMAND

BIT BYTE(S)	7	6	5	4	3	2	1	0
0	0	0	0	0	0	0	0	0
1	LOGICAL UNIT NO.			0	0	0	0	0
2	0	0	0	0	0	0	0	0
3	0	0	0	0	0	0	0	0
4	0	0	0	0	0	0	0	0
5	0	0	0	0	0	0	FLAG	LINK
	0	0	0	0	0	0	0	0

The Test Unit Ready command provides a means to verify the logical unit is ready. This is not a request for a self test. If the logical unit would accept an appropriate medium access command without returning check condition status, the WREN V will return a Good status. For WREN V, the flag and link bits must be zero, and the only valid Logical Unit Number is zero. See Table 14.1.1-2 for proper format.

14.1.1.2 Request Sense Command (03H)

TABLE 14.1.1-3. REQUEST SENSE COMMAND

BIT BYTE(S)	7	6	5	4	3	2	1	0
0	0	0	0	0	0	0	1	1
1	LOGICAL UNIT NO.							
	0	0	0	0	0	0	0	0
2	0	0	0	0	0	0	0	0
3	0	0	0	0	0	0	0	0
4	ALLOCATION LENGTH IN BYTES							
5							FLAG	LINK
	0	0	0	0	0	0	0	0

The Request Sense command (TABLE 14.1.1-3) requests that the WREN V transfer sense data to the initiator in the format shown in Table 14.1.1-4. The sense data shall be valid for a Check Condition status returned on the prior command. This sense data shall be preserved by the WREN V for the initiator until retrieval is requested by the initiator sending the Request Sense command or until the receipt of any other command for the same logical unit from the initiator that issued the command resulting in the Check Condition status. Sense data shall be cleared upon receipt of any subsequent command to the logical unit from the initiator receiving the Check Condition status.

If a WREN V sends a Check Condition status as a response to a Request Sense command being in error, it shall do so only if the error was a fatal error. For example:

1. The WREN V receives a nonzero reserved bit in the command descriptor block.
2. An unrecovered parity error occurs on the Data Bus.
3. A WREN V malfunction prevents return of sense data.

14.1.1.2 continued

If any nonfatal error occurs during execution of Request Sense, the WREN V shall return sense data with Good status. Following a fatal error on a Request Sense command, sense data may be invalid.

The Allocation Length in byte four of the format shown specifies the number of bytes the initiator has allocated for returned sense data. The Allocation Length should always be at least 18 bytes for WREN V devices for the initiator to receive all of the WREN V sense data. Any other value indicates the maximum number of bytes that shall be transferred. The WREN V shall terminate the Data In phase when allocation length bytes have been transferred or when all available sense data have been transferred to the initiator, whichever is less. If the Allocation Length is zero, the WREN V will return 4 bytes of sense data in Extended Sense Data Format. The WREN V always returns sense data in the Extended Sense Data Format. The Flag and Link bits in the Request Sense command must always be zero for WREN V.

Extended Sense Data Format

WREN V is capable of sending 18 bytes of extended sense data, and will send 18 bytes if the Allocation Length of the Request Sense Command is equal to or greater than 18 bytes (otherwise, the number of bytes specified by the Allocation Length will be sent). The Extended Sense Data Format is summarized in Table 14.1.1-4. Numbers in parentheses in the sense data are references to notes following the table. A "1" or a "0" means the data bit will always be logic 1 or logic 0, respectively, when sent by a WREN V.

TABLE 14.1.1-4. WREN V EXTENDED SENSE DATA SUMMARY

BYTE	BIT	7	6	5	4	3	2	1	0
0	VALIDITY BIT (1)	1	1	1	0	0	0	0	0
		ERROR CLASS (2)			SENSE KEY (3)				
1		0	0	0	0	0	0	0	0
		SEGMENT NUMBER (4)							
2	FILEMARK (5)	0	0	0	0	SENSE KEY (8)			
		EOM (6)	ILI (7)						
3		INFORMATION BYTE (MSB) (9)							
4		:							
5		:							
6		INFORMATION BYTE (LSB) (9)							
7		ADDITIONAL SENSE LENGTH - Decimal 10 (Max) (10)							
8		Bytes 8 - 11 are Reserved for use by Copy or Search commands. Will be all zeros.							
9									
10									
11									
12		ERROR CODE (11)							
13		RESERVED (All Zeros)							
14		FRU CODE (12)							
15	FPV (13)	C/D (14)	0	0	BPV (16)	BIT POINTER (17)			
16		FIELD POINTER (MSB) (15)							
17		FIELD POINTER (LSB) (15)							
18-n		PRODUCT UNIQUE SENSE DATA (18)							

TABLE 14.1.1-4. WREN V EXTENDED SENSE DATA SUMMARY (continued)

NOTES:

- (1) Validity Bit - "1" if the Information Bytes (Bytes 3-6) are valid, "0" if not valid.
- (2) Error Class - "111" (7) indicates Extended Sense is being used here.
- (3) "0000" specifies the Extended Sense Data Format. Byte 12 has error codes for Extended Sense.
- (4) Segment Number - Always Zeros
- (5) Filemark - Always "0" for WREN V.
- (6) EOM - End of medium indicator. Always "0" for WREN V.
- (7) ILI - Incorrect Length Indicator. The requested (previous command) block of data did not match the logical block length of the data on the medium.
- (8) Sense Key - Indicates nine (for WREN V) general error categories. These are listed in Table 14.1.1-5. the code given in byte 12 provides additional clarification of errors. See also note 15 below for related information.
- (9) If the validity bit is a 1, the Information Bytes will contain the unsigned Logical Block Address associated with the Sense Key. Unless otherwise specified, the Information Bytes will contain the address of the current logical block. For example, if the Sense Key is Medium Error, it will be the Logical Block Address of the failure block.
- (10) Additional Length - Specifies additional sense bytes are to follow. This is limited to a maximum of 10 (decimal) additional bytes. If the Allocation length of the Command Descriptor Block is too small to transfer all of the additional sense bytes, the additional sense length is not adjusted to reflect the truncation.
- (11) Error Code - Provides additional clarification of errors whenever Sense Key is valid. Error code definitions are in Table 14.1.1-6.

TABLE 14.1.1-4. WREN V EXTENDED SENSE DATA SUMMARY (continued)

NOTES: (continued)

- (12) FRU (Field Replaceable Unit) Code - Defined for Field Maintenance personnel only.
- (13) FPV (Field Pointer Valid) bit - When set to one, indicates that the C/D bit and bytes 16 and 17 are valid. When zero, ignore these fields.
- (14) C/D Bit - Command/Data bit, when set to one, indicates that the value reported in the field pointer bytes is the CDB's byte number for which an Illegal Request Sense Key was issued. When set to zero, it indicates that the value reported in the field pointer bytes is the byte number in the data phase for which an Illegal Request Sense Key was issued. See also Note 15.
- (15) Field Pointer (MSB) Refer to Table 14.1.1-5 for details
Field Pointer (LSB) on the Illegal Request Sense Key description. The Illegal Request extended sense report uses the 16 bit Field Pointer to point to the first byte in a Command Descriptor Block or associated data block where an illegal parameter was detected, causing the Illegal Request Sense Key.
- (16) BPV - Bit Pointer Valid Bit, when set to one, indicates that the Bit Pointer field is valid.
- (17) Bit Pointer Field - Indicates which bit of the byte indicated by the Field Pointer caused the Illegal Request Sense Key. A value of 7 indicates the leftmost bit and zero indicates the rightmost bit.
- (18) Not presently used by the WREN V.

14.1.1.2 continued

Table 14.1.1-5 lists the Sense Keys in the extended sense data format that are used by the WREN V.

14.1.1.2 continued

TABLE 14.1.1-5. APPLICABLE WREN V SENSE KEYS

<u>SENSE KEY</u>	<u>DESCRIPTION</u>
0H	No Sense - Indicates there is no specific Sense Key information to be reported for the WREN V. This would be the case for a successful command.
1H	Recovered Error - Indicates the last command completed successfully with some recovery action performed by the WREN V. NOTE: For some Mode settings, the last command may have terminated before completing.
2H	Not Ready - Indicates the logical unit addressed cannot be accessed. Operator intervention may be required to correct this condition.
3H	Medium Error - Indicates the command terminated with a nonrecovered error condition, probably caused by a flaw in the medium or an error in the recorded data.
4H	Hardware Error - Indicates the WREN V detected a nonrecoverable hardware failure while performing the command or during a self test. This includes SCSI interface parity error, controller failure, device failure, etc.
5H	Illegal Request - Indicates an illegal parameter in the command descriptor block or in the additional parameters supplied as data for some commands (Format Unit, Mode Select, etc). If the WREN V detects an invalid parameter in the Command Descriptor Block, it shall terminate the command without altering the medium. If the WREN V detects an invalid parameter in the additional parameters supplied as data, the WREN V may have already altered the medium.
6H	Unit Attention - Indicates the WREN V may have been reset. See Paragraph 13.1.3 for more detailed information about the Unit Attention Condition.
BH	Aborted Command - Indicates the WREN V aborted the command. The initiator may be able to recover by trying the command again.
DH	Volume Overflow - Indicates a buffered peripheral device has reached the end of medium and data remains in the buffer that has not been written to the medium.
EH	Miscompare - Indicates that the source data did not match the data read from the medium.

14.1.1.2 continued

TABLE 14.1.1-6. DIRECT ACCESS DEVICES, ADDITIONAL SENSE ERROR CODES

<u>ERROR CODE</u>	<u>DESCRIPTION</u>	<u>MOST PROBABLE RELATED SENSE KEYS. OTHER SENSE KEYS MAY APPLY TO ADDITIONAL SENSE CODES.</u>
00	No additional information	No Sense
01	No Index/Address Mark Found signal	Hardware error
02	No Seek Complete	Hardware error
03	Write Fault	Hardware Error or Recovered Error
04	Drive not ready	Not Ready or Recovered Error
08	Logical Unit communication failure	Hardware error or Recovered Error
09	Track Following error	Hardware error or Recovered Error
10	ID CRC or ECC error	Hardware Error or Medium error or Recovered Error
11	Unrecovered Read error	Medium error or Recovered error
12	No Address Mark (byte sync byte) found in ID field	Medium error or Recovered error
13	No Address Mark (byte sync byte) found in Data Field	Medium error or Recovered error
14	No record found	Medium error or Recovered error
15	Seek Positioning error	Hardware error or Medium error or Recovered error
17	Recovered Read data with target's Read retries (not with ECC)	Recovered error
18	Recovered Read data with target's ECC correction (not with retries)	Recovered error
19	Defect List error	Medium error
1A	Parameter overrun	Illegal request
1B	Synchronous transfer error	Hardware error
1C	Primary Defect List not found	Medium error
1D	Compare error	Miscompare

14.1.1.2 continued

TABLE 14.1.1-6. DIRECT ACCESS DEVICES, ADDITIONAL SENSE ERROR CODES
(continued)

<u>ERROR CODE</u>	<u>DESCRIPTION</u>	<u>MOST PROBABLE RELATED SENSE KEYS. OTHER SENSE KEYS MAY APPLY TO ADDITIONAL SENSE CODES.</u>
20	Invalid Command Operation Code	Illegal Request
21	Illegal Logical Block Address. Address greater than the LBA returned by the Read Capacity data with PMI bit not set in CDB.	Illegal Request
22	Illegal function for device type	Illegal Request
24	Illegal use of bit of byte in CDB	Illegal Request
25	Invalid LUN	Illegal Request
26	Invalid field in parameter list	Illegal Request
29	Power On or Reset or Bus Device Reset	Unit Attention
2A	Mode Select Parameters changed by another initiator	Unit Attention
2B	Firmware has been downloaded	Unit Attention
31	Medium Format corrupted	Medium error
32	No Spare Defect Locations Available	Medium error
40	RAM failure	Hardware error
41	Data Path diagnostic failure	Hardware error
42	Power On diagnostic failure	Hardware error
43	Message Reject Error	Aborted Command
44	Internal controller error	Hardware error or Not Ready
45	Selection/Reselection failure	Recovered error
47	SCSI interface bus parity error	Aborted Command
48	Initiator detected error	Hardware error
49	Inappropriate/illegal message	Aborted Command
80 thru FF	Product Unique Error Codes	

14.1.1.3 Inquiry Command (12H)

TABLE 14.1.1-7. INQUIRY COMMAND

BIT	7	6	5	4	3	2	1	0
0	0	0	0	1	0	0	1	0
1	LOGICAL UNIT NO.							
	0	0	0	0	0	0	0	0
2	0	0	0	0	0	0	0	0
3	0	0	0	0	0	0	0	
4	ALLOCATION LENGTH IN BYTES							
5							FLAG	LINK
	0	0	0	0	0	0	0	0

In Inquiry command (Table 14.1.1-7) requests that information regarding parameters of the WREN V be sent to the initiator.

The Allocation Length specifies the number of bytes the initiator has allocated for returned Inquiry data. An Allocation Length of zero indicates that no Inquiry data shall be transferred. This condition shall not be considered as an error. Any other value indicates the maximum number of bytes that shall be transferred. The WREN V shall terminate the Data In phase when Allocation Length bytes have been transferred or when all available Inquiry data have been transferred to the initiator, whichever is less. The Initiator should have an allocation length of 36 minimum in order to receive all of the WREN V's Inquiry Data.

A Check Condition status shall be reported only when the WREN V cannot return the requested Inquiry data. Inquiry Data may be returned even though the WREN V is not ready for other commands (i.e. prior to receiving a Start Unit command if the WREN V is configured to require a Start Unit command to start the spindle motor).

14.1.1.3 (continued)

If an Inquiry command is received from an initiator with a pending Unit Attention Condition (before the WREN V reports Check Condition status), the WREN V shall perform the Inquiry command and shall not clear the Unit Attention Condition.

In Inquiry data (Table 14.1.1-8) contains a five byte header, followed by the vendor unique parameters, if any.

The Inquiry command is implemented with the following WREN V drive specific parameters:

Flag and Link bits must be zero. The initiator should allocate 36 bytes of inquiry data. The Inquiry command format is shown in Table 14.1.1-7. Inquiry data returned by the WREN V to the initiator is summarized in Table 14.1.1-8 and 14.1.1-9.

TABLE 14.1.1-8. INQUIRY DATA SUMMARY

BIT	7	6	5	4	3	2	1	0
0	DEVICE TYPE (OOH or 7FH-LUN NOT PRESENT)							
1	RMB 0	DEVICE TYPE QUALIFIER (OOH)						
2	ISO VERSION (OH)		ECMA VERSION (OH)			ANSI VERSION (LH)		
3	0	0	0	0	RESPONSE DATA FORMAT (LH)			
4	ADDITIONAL LENGTH (n) (LFH)							

Device Type: 00H indicates a Direct Access Device (i.e., Magnetic Disk)

7FH indicates the Requested LUN is not present.

RMB: 0H indicates the medium is not removable.

Device Type Qualifier: 00H indicates this field is not supported.

ISO Version: 0H indicates the WREN V does not claim compliance to the ISO version.

ECMA Version: 0H indicates the WREN V does not claim compliance to the ECMA version.

ANSI Version: 1H indicates compliance to the first release of the ANSI SCSI Standard (i.e. ANSI X3.131-1986)

Response Data Format: 1H indicates the format of the additional inquiry data (bytes 5-35) is compatible to the Common Command Set (CCS) definition.

Allocation Length: 1FH (31) specifies the length of additional inquiry data. If the allocation length in the CDB is too small to transfer all of the Inquiry Data, this additional length shall not be adjusted to reflect the truncation.

TABLE 14.1.1-8. INQUIRY DATA SUMMARY (continued)

COMMON COMMAND SET PARAMETERS	
5	CDC RESERVED (12H)
6	CDC RESERVED (00H)
7	CDC RESERVED (00H)
8	VENDOR IDENTIFICATION: ASCII 'C' (43H) [1]
9	VENDOR IDENTIFICATION: ASCII 'D' (44H)
10	VENDOR IDENTIFICATION: ASCII 'C' (43H)
11	VENDOR IDENTIFICATION: ASCII "BLANK" (20H)
12	VENDOR IDENTIFICATION: ASCII "BLANK" (20H)
13	VENDOR IDENTIFICATION: ASCII "BLANK" (20H)
14	VENDOR IDENTIFICATION: ASCII "BLANK" (20H)
15	VENDOR IDENTIFICATION: ASCII "BLANK" (20H)
16	PRODUCT IDENTIFICATION: ASCII '9' (39H)
17	PRODUCT IDENTIFICATION: ASCII '4' (34H)
18	PRODUCT IDENTIFICATION: ASCII '1' (31H)
19	PRODUCT IDENTIFICATION: ASCII '8' (36H)
20	PRODUCT IDENTIFICATION: ASCII '1' (31H)
21	PRODUCT IDENTIFICATION: ASCII '-' (2DH)
22	PRODUCT IDENTIFICATION: ASCII [2] [MSB]
23	PRODUCT IDENTIFICATION: ASCII [2] [LSB]
24	PRODUCT IDENTIFICATION: ASCII "BLANK" (20H)
25	PRODUCT IDENTIFICATION: ASCII "BLANK" (20H)
26	PRODUCT IDENTIFICATION: ASCII "BLANK" (20H)
27	PRODUCT IDENTIFICATION: ASCII "BLANK" (20H)
28	PRODUCT IDENTIFICATION: ASCII "BLANK" (20H)
29	PRODUCT IDENTIFICATION: ASCII "BLANK" (20H)
30	PRODUCT IDENTIFICATION: ASCII "BLANK" (20H)
31	PRODUCT IDENTIFICATION: ASCII "BLANK" (20H)
32	REVISION LEVEL: ASCII FIRMWARE VERSION NO.
33	REVISION LEVEL: ASCII FIRMWARE VERSION NO.
34	REVISION LEVEL: ASCII FIRMWARE VERSION NO.
35	REVISION LEVEL: ASCII FIRMWARE VERSION NO.

[1] SCSI Data fields shall have the most significant byte returned first with no leading spaces as shown.

[2] The dash number representing the drive configuration is given in Table 14.1.1-9.

TABLE 14.1.1-9. INQUIRY DATA BYTES 22 & 23, DRIVE MODEL DASH NUMBER

<u>BYTES 22, 23</u>	<u>DRIVE CONFIGURATION</u>
15	15 Headed Drive
13	13 Headed Drive
Blank (20H)	Number of Heads not yet known. The drive spindle motor not yet up to speed and ready.

14.1.1.4 Copy Command (18H)

Not Implemented. If received the WREN V will send a "Check Condition" status and a Sense Key of "Illegal Request".

14.1.1.5 Receive Diagnostic Results Command (1CH)

TABLE 14.1.1-10. RECEIVE DIAGNOSTIC RESULTS COMMAND

BIT	7	6	5	4	3	2	1	0
BYTE(S)								
0	0	0	0	1	1	1	0	0
1	LOGICAL UNIT NO.							
	0	0	0	0	0	0	0	0
2	0	0	0	0	0	0	0	0
3	ALLOCATION LENGTH IN BYTES (MSB)							
4	ALLOCATION LENGTH IN BYTES (LSB)							
5	0	0	0	0	0	0	FLAG	LINK
							0	0

14.1.1.5 continued

TABLE 14.1.1-11. CDC DIAGNOSTIC DATA BYTES

<u>CODE</u>	<u>BYTE</u>	<u>DESCRIPTION</u>
00H	0	Additional Length (MSB)
06H	1	Additional Length (LSB)
01H	2	FRU Code (most probable)
00H	3	FRU Code
00H	4	FRU Code
00H	5	FRU Code (least probable)
00H	6	Error Code (MSB)
V.U.*	7	Error Code (LSB)

Additional Length:

This two byte value indicates the number of additional bytes included in the diagnostic data list. For example, if no product unique bytes were available, this value would be 0006H. A value of 0000H means that there are no additional bytes.

14.1.1.5 continued

TABLE 14.1.1-11. CDC DIAGNOSTIC DATA BYTES (continued)
(Table 7-24 in CDC SCSI Spec)

FRU Code: A Field Replaceable Unit code is a byte that identifies an assembly that may have failed. The codes will be listed in probability order, with the most probable assembly listed first and the least probable listed last. A code of 00H indicates there is no FRU information and a code of 01H indicates the entire unit should be replaced. Other values have product unique meanings.

Error Code: This two byte value provides information designating which part of a diagnostic operation has failed. The byte 7 error code is vendor unique and defined as follows.

* Vendor Unique

Diagnostic Fault Codes

01H	Formatter Diagnostic Error
02H	Microprocessor RAM Diagnostic Error
04H	No Drive Ready
08H	No Sector or Index Detected
09H	Fatal Hardware Error While Doing Drive Diagnostics
0CH	No Drive Command Complete
10H	Unable to Set Drive Sector Size
14H	Unable to Clear Drive Attention
18H	Unable to Start Spindle Motor
20H	Unable to Recal Drive
30H	Unable to Send Write Current Data to Drive
34H	Unable to Issue Drive Seek Command
40H	Unable to Read User Table From Drive
41H	Ran Out of Sectors While Doing Drive Diagnostics
42H	Unable to Read Reallocation Table
43H	Unable to Read ETF Log
60H	Thermal Calibration Failure
70H	Microprocessor Internal Timer Error
80H	Buffer Controller Diagnostic Error
81H	Buffer RAM Diagnostic Error
ClH	Data Miscompare While Doing Drive Diagnostics

14.1.1.6 Send Diagnostic Command (LDH)

TABLE 14.1.1-12. CDB REQUIREMENTS FOR SEND DIAGNOSTIC COMMAND

BIT BYTE(S)	7	6	5	4	3	2	1	0
0	0	0	0	1	1	1	0	1
1	LOGICAL UNIT NO.				SELF- TEST	DEV- OFL	UNIT OFL	
	0	0	0	0	0	1	0	0
2	0	0	0	0	0	0	0	0
3	PARAMETER LIST LENGTH (MSB)							
	0	0	0	0	0	0	0	0
4	PARAMETER LIST LENGTH (LSB)							
	0	0	0	0	0	0	0	0
5						FLAG	LINK	
	0	0	0	0	0	0	0	0

This command requests the WREN V to perform diagnostic tests on itself. It is implemented with the WREN V interpretations listed in Table 14.1.1-12.

Parameter List Length specifies the length in bytes of the parameter list that shall be transferred during the Data Out phase. A Parameter List Length of zero indicates that no data out shall be transferred. This condition shall not be considered as an error. The parameter list is vendor unique and reserved for future standardization by CDC. The WREN V will accept only a parameter list length of zero.

A logical Unit Off Line (UnitOfL) bit of zero disables write operations on user medium or operations that affect user visible medium positioning. The bit is not interpreted by the WREN V.

The SCSI Device Off Line (DOFL) bit of 1 enables diagnostic operations that may adversely affect operations to other Logic Units on the same target. This bit is not interpreted by the WREN V.

14.1.1.6 continued

The Logical Unit Off Line and SCSI Device Off Line bits are generally set by operating system software, while the parameter list is prepared by diagnostic application software. Thus, by preventing operations that are not enabled by these bits, the WREN V assists the operating system in protecting it's resources.

A Self Test bit of one directs the WREN V to complete it's default self test. If the self test is requested, the Parameter List Length shall be set to zero and no data shall be transferred. If the self test successfully passes, the command shall be terminated with a Good Condition status; otherwise, the command shall be terminated with a check condition status and, if extended sense is implemented, the Sense Key shall be set to Hardware Error. For the WREN V, the self test bit must be set to a 1.

WREN V performs only it's default self test. This will include seeking to a reserved nonuser-accessible cylinder and writing, reading and verifying data for each data surface.

For systems which support disconnection, WREN V will disconnect while executing this command.

14.1.2 GROUP 1 COMMANDS FOR ALL DEVICE TYPES

WREN V implements the following commands which are applicable for all device types.

<u>OP CODE</u>	<u>COMMAND NAME</u>	<u>SECTION</u>
3BH	Write Data Buffer	14.1.2.3
3CH	Read Data Buffer	14.1.2.4

14.1.2.1 Compare Command (39H)

Not Implemented

14.1.2.2 Copy and Verify Command (3AH)

Not Implemented

14.1.2.3 Write Data Buffer Command (3BH)

TABLE 14.1.1-13. WRITE DATA BUFFER COMMAND

BIT BYTE(S)	7	6	5	4	3	2	1	0
0	0	0	1	1	1	0	1	1
1	LOGIC UNIT NO.			MODE				
	0	0	0	0	0			
2	0	0	0	0	0	0	0	0
3	0	0	0	0	0	0	0	0
4	0	0	0	0	0	0	0	0
5	0	0	0	0	0	0	0	0
6	0	0	0	0	0	0	0	0
7	BYTE TRANSFER LENGTH (MSB)							
8	BYTE TRANSFER LENGTH (LSB)							
9	0	0	0	0	0	0	FLAG	LINK
							0	0

The Write Data Buffer command may be used in conjunction with the Read Buffer command as a diagnostic function for testing the WREN V's data buffer memory and the SCSI bus integrity. When used in a diagnostic mode, the medium shall not be accessed during the execution of this command. An additional mode is provided for downloading and saving executable micro-code.

The function of this command and the meaning of the fields within the Command Descriptor Block depend on the mode field. The mode field is defined as follows:

DB2	DB1	DB0	MODE DEFINITION
0	0	0	Write combined header and data
1	0	1	Download microcode and save

14.1.2.3.1 Combined Header and Data Mode (000b)

In this mode, data to be written to the Drives data buffer is preceded by a four byte header.

The Byte Transfer Length includes a four byte header and the Write Data Buffer data. In WREN V, up to 32,772 bytes may be transferred, consisting of four bytes of header and up to 32,768 bytes of data. Writing will be initiated at "Byte Number 0" of the WREN V data buffer. A transfer length of zero indicates that no data transfer shall take place. This condition shall not create the Check Condition status. If the transfer length is greater than the Available Length reported by the Read Data Buffer header, the WREN V shall create the Check Condition status with the Sense Key of Illegal Request. In this case no data shall be transferred from the initiator.

It shall not be considered an error to request a transfer length less than the Available Length.

The write data following the Write Data Buffer CDB consists of a 4 byte write data buffer header (which always precedes the data) plus the data to be written to the data buffer as follows:

TABLE 14.1.1-14a. WRITE DATA BUFFER HEADER

BIT BYTE(S)	7	6	5	4	3	2	1	0
0	0	0	0	0	0	0	0	0
1	0	0	0	0	0	0	0	0
2	0	0	0	0	0	0	0	0
3	0	0	0	0	0	0	0	0
4 - n	DATA TO BE WRITTEN INTO WREN V BUFFER							

14.1.2.3.1 Combined Header and Data Mode (000b)

In this mode, vendor-unique executable microcode (which is not preceded by a 4 byte header) and/or control information shall be transferred to the control memory space of the target and, if the download is completed successfully, shall also be saved on the disk media. The downloaded code shall then be effective after each power cycle and reset until it is supplanted in another download microcode and save operation. When the download microcode and save command has been completed successfully the target shall generate a "Unit Attention Condition" for all initiators except the one that issued the download microcode and save command. The Attention Condition shall be set to "Microcode has been downloaded" (error code 2Bh).

Buffer ID (CDB byte 2):

Not checked or interpreted by the drive.

Buffer Offset (CDB bytes 3, 4, and 5):

Not checked or interpreted by the drive.

Transfer Length (CDB bytes 6, 7 and 8):

The transfer length in bytes of the downloadable code. This value must be the exact length of the download data. A value of zero signifies no data transfer and shall not create an error. A value of one signifies one byte of download data, etc.

Control Byte (CDB byte 9):

Must-Be-Zero.

14.1.2.4 Read Data Buffer Command (3CH)

TABLE 14.1.1-14b. READ DATA BUFFER CDB PARAMETERS

BIT BYTE(S)	7	6	5	4	3	2	1	0
0	0	0	1	1	1	1	0	0
1	LOGICAL UNIT NO.							
	0	0	0	0	0	0	0	0
2	0	0	0	0	0	0	0	0
3	0	0	0	0	0	0	0	0
4	0	0	0	0	0	0	0	0
5	0	0	0	0	0	0	0	0
6	0	0	0	0	0	0	0	0
7	ALLOCATION LENGTH (MSB) [1]							
8	ALLOCATION LENGTH (LSB) [1]							
9	0	0	0	0	0	0	FLAG	LINK
							0	0

[1] Should be 32,772 decimal to read the drive's entire buffer plus the 4 byte read data buffer header (Figure 14.1.1-15).

The Read Data Buffer command is used in conjunction with the Write Data Buffer command as a diagnostic function for testing the WREN V's data buffer memory and the SCSI bus integrity. The medium shall not be accessed during the execution of this command.

The Read Data Buffer command is implemented with the WREN V parameters listed in Table 14.1.1-14b.

14.1.2.4 continued

The Allocation Length specifies the number of bytes the initiator has allocated for returned Read Data Buffer data. An Allocation Length of zero indicates that no Read Data Buffer data shall be transferred. This condition shall not create the Check Condition status. Any other value indicates the maximum number of bytes to be transferred. This data is to be used by the initiator for comparison with the data pattern sent during the Write Data Buffer command. Up to 32,772 bytes may be requested consisting of four bytes of header and up to 32,768 bytes of data.

If the Allocation Length is greater than the Available Length (from Read Data Buffer Header), only the Available Length shall be transferred to the initiator. It shall not be considered an error to request an Allocation Length less than the Available Length.

The WREN V shall terminate the Data In phase when Allocation Length bytes have been transferred or when all available Read Data Buffer data have been transferred to the initiator, whichever is less.

The Read Data Buffer contains a four byte header, followed by the Read Data Buffer data.

TABLE 14.1.1-15. READ DATA BUFFER HEADER

BIT BYTES	7	6	5	4	3	2	1	0
0	0	0	0	0	0	0	0	0
1	0	0	0	0	0	0	0	0
2	AVAILABLE LENGTH (MSB) [2]							
3	AVAILABLE LENGTH (LSB) [2]							
4-n	BUFFER DATA BYTES							

[2] 32,768 Bytes

To avoid corruption of data, it is recommended that the initiator issue the Reserve Unit command before the Write Data Buffer command and issue Release Unit command after the Read Data Buffer command.

14.1.2.4 continued

The Available Length of data bytes returned by the WREN V may be up to 32,768 bytes (32,772 bytes minus 4 byte header) If the Allocation Length of the CDB is too small to transfer all of the Available Length, the Available Length shall not be adjusted to reflect the truncation.

Reading will be initiated from "Byte Number 0" of the WREN V data buffer. The drive will not attempt to detect whether buffer data has been changed between Write and Read Data Buffer commands.

14.1.3 Groups 2 through 5 Commands for All Device Types

Not implemented. A "Check Condition" status will be sent if received.

14.1.4 Group 6 Commands for All Device Types

Reserved for CDC usage. Customers should not attempt to use these functions. If these functions are used, the users stored data may be destroyed.

14.1.5 Group 7 Commands for All Device Types

Same as Group 6 Commands.

14.2 COMMAND DESCRIPTIONS FOR DIRECT ACCESS DEVICES

The WREN V supports Group 0, and Group 1 commands for Direct Access Devices. Refer to sections listed below for more details on these commands.

14.2.1 Group 0 Commands for Direct Access Devices

The Group 0 Commands implemented by WREN V are listed in Table 14.2.1-1.

TABLE 14.2.1-1. GROUP 0 COMMANDS IMPLEMENTED

<u>OPERATION CODE (HEX)</u>	<u>COMMAND NAME</u>	<u>SECTION</u>
00	TEST UNIT READY	14.1.1.1
01	REZERO UNIT	14.2.1.1
03	REQUEST SENSE	14.1.1.2
04	FORMAT UNIT	14.2.1.2
07	REASSIGN BLOCKS	14.2.1.3
08	READ	14.2.1.4
0A	WRITE	14.2.1.5
0B	SEEK	14.2.1.6
12	INQUIRY	14.1.1.3
15	MODE SELECT	14.2.1.7
16	RESERVE	14.2.1.8
17	RELEASE	14.2.1.9
1A	MODE SENSE	14.2.1.10
1B	START UNIT	14.2.1.11
1C	RECEIVE DIAGNOSTIC RESULTS	14.1.1.5
1D	SEND DIAGNOSTIC	14.1.1.6

14.2.1.1 Rezero Unit Command (01H)

TABLE 14.2.1-2. REZERO UNIT COMMAND CDB SPECIFICATION
(Table 8.2 in CDC SCSI Spec)

BIT BYTES	7	6	5	4	3	2	1	0
0	0	0	0	0	0	0	0	1
1	LOGICAL UNIT NO.							
	0	0	0	0	0	0	0	0
2	0	0	0	0	0	0	0	0
3	0	0	0	0	0	0	0	0
4	0	0	0	0	0	0	0	0
5							FLAG	LINK
	0	0	0	0	0	0	0	0

The Rezero Unit command (Table 14.2.1-2) requests that the WREN V set it's logical block address to zero and return the disk drive read/write heads to the track (or cylinder) containing Logical Block Zero. This command is implemented for a LUN of zero and Flag and Link bits of zero. This command is intended for systems which disable retries and the initiator performs error recovery. It is longer than a seek to Logical Block Address zero and should be utilized if seek errors are encountered.

For systems that support disconnection, WREN V will disconnect when this command is received.

14.2.1.2 Format Unit Command (04H)

TABLE 14.2.1-3. FORMAT UNIT COMMAND CDB SPECIFICATION

BIT BYTE(S)	7	6	5	4	3	2	1	0
0	0	0	0	0	0	1	0	0
1	LOGICAL UNIT NO.			FMT DATA	CMP- LIST	DEFECT LIST FORMAT		
	0	0	0	[1]	[1]	[1]		
2	0	0	0	0	0	0	0	0
3	INTERLEAVE (MSB)							
4	INTERLEAVE (LSB) (a value of 0000H defaults to an interleave of 1)							
5	0	0	0	0	0	0	0	0

[1] See Table 14.2.1-4 for details of values used here and their meanings.

The Format Unit command (Table 14.2.1-3) ensures that the medium is formatted so all of the user addressable data blocks can be accessed. There is no guarantee that the medium has or has not been altered. In addition, the medium may be certified and control structures may be created for the management of the medium and defects.

The Format Unit command shall be rejected with Reservation Conflict status (see Section 14.2.1.8.2) if the specified logical unit is reserved. Extent reservation is not supported by WREN V.

This command is implemented in WREN V for a LUN of zero, mandatory features and a subset of the available optional features of the Common Command Set (CCS) specification and CDC SCSI specification as defined in the following paragraphs.

WREN V allows an initiator to specify (or not specify) sectors which are to be reallocated during the format process. The format parameters to be specified in the Format Unit command are defined in Table 14.2.1-3.

14.2.1.2 continued

A Format Data (FmtData) bit of one indicates that format data is supplied during the Data Out phase. The defect list included with this data specifies the defects that shall be entered into the defect map. The format of the defect list is determined by Defect List Format field. A FmtData bit of zero indicates the Data Out phase shall not occur (no defect data shall be supplied by the initiator).

A Complete List (CmpLst) bit of one indicates the data supplied is to be the complete list of Growth defects. Any previous Growth or Certification defect data shall be erased. The WREN V may add to this list as it formats the medium. The result is to purge any previous Growth or Certification defect list and to build a new defect list. A CmpLst bit of zero indicates the data supplied is in addition to existing Growth defect list.

The use of the P and C defect lists is controlled by byte 1 of the defect list header (see Table 14.2.1-5).

The Defect List Format field specifies additional information related to the defect list. (See Table 14.2.1-4 for further information.)

The Interleave field requests that logical blocks be related in a specific fashion to the physical blocks to facilitate speed matching. An interleave value of zero requests that the target use it's default interleave. An interleave value of one requests that consecutive logical blocks be placed in consecutive physical order. Values of two or greater indicate that one or more (respectively) physical blocks separate consecutive logical blocks. The WREN V has implemented an optional "read look ahead" function which reads all of the data from the starting block address to the end of the last track read into it's buffer regardless of the block count specified in the read command. This data (from the last block read to the end of the track) is subsequently available for the next sequential read command without reaccess of the disk media thereby increasing performance and negating the need for an interleave during format if this "read look ahead" option is enabled. (See Read Command, Section 14.2.1.4.)

14.2.1.2 continued

These definitions of flaw categories are supplied to help in understanding the alternatives listed in Table 14.2.1-4.

- P = Primary Defect Type: P type flawed sectors are identified at the time of shipment in a list of defects (permanent flaws) supplied by CDC and stored on the disk in an area that is not directly accessible by the user. (This list may be referred to as an ETF List). This defect list will not be modified or changed by WREN V (or initiator) after shipment.
- C = Certification Defect Type: C type flawed sectors are sectors which fail a format verify during the format function.
- D = Data Defect Type: D type sectors are sectors identified in a list supplied to the target by the initiator during a Data Out phase of the current Format Unit command. The D List follows a four byte defect list header and is referred to as Defect Descriptor Bytes.
- G = Growth Defect Type: G type flawed sectors contain medium flaws and have been reallocated as a result of receiving a Reassign Blocks command, or certification defects (C type) reallocated during a previous Format Unit command, or Data Defects (D type) reallocated during a previous Format Unit command or defects that have been automatically reallocated by the drive. This (G) list is recorded on the WREN V media and may be referenced for the current (and subsequent) Format Unit commands. This (G) list does not include the Primary (P) list of defects.

14.2.1.2 continued

TABLE 14.2.1-4. FORMAT UNIT PARAMETER DEFINITION (FORMAT VARIATIONS)

CDB-Byte 1				COMMENTS
Bits 1				
4	3	2	1 0	
FMT	CMP	DEFECT		
DATA	LIST	LIST	FORMAT	
0	X	X X X		Default Format: No Data Out phase occurs. WREN V will reallocate all sectors in the P list plus any sector which fails the Format Verify phase (C type flaws). Any previous G list will be erased:
1	0	0 X X		Format with G and no D: A four byte Defect List Header must be sent by the initiator. No Defect Descriptors (D list) are sent by the initiator. WREN V will reallocate all sectors in the drives current G list. See also note [2].
1	1	0 X X		Format without G or D: A four byte Defect List Header must be sent by the initiator. No D list may be sent by the initiator. WREN V will erase any previous G list. See also note [2].
1	1	1 0 0		Format with D and without G. The initiator must send a four byte Defect List Header followed by a D list of the defects that the WREN V will reallocate. The D list must be in the bytes from Index format (see Table 14.2.1-6A). The WREN V will erase any previous G list. See also Note [2].
1	1	1 0 1		Format with D and without G: The initiator must send a four byte Defect List Header followed by a D List of defects that WREN V will reallocate. The D list must be in the Physical Sector format (see Table 14.2.1-6B). WREN V will erase any previous G list. See also Note [2].
1	0	1 0 0		Format with D and with G: The initiator must send a four byte Defect List Header followed by a D list of the defects that the WREN V will reallocate. The D list must be in the bytes from Index format (see Table 14.2.1-6A). The WREN V will also reallocate all sectors in the drives current G list. See also note [2].
1	0	1 0 1		Format with D and with G: The initiator must send a four byte Defect List Header followed by a D List of defects that WREN V will reallocate. The D list must be in the Physical Sector format (see Table 14.2.1-6B). The WREN V will also reallocate all sectors in the drives current G list. See also note [2].

[1] Refer to Table 14.2.1-3.

[2] Byte one of the Defect List Header determines whether the P and C defects are reallocated. See Table 14.2.1-5.

14.2.1.2 continued

The defect list shown in Table 14.2.1-5 contains a four byte header followed by one or more defect descriptors. The Defect List Length in each table specifies the total length in bytes of the defect descriptors that follow. In Table 14.2.1-5 the Defect List Length is equal to eight times the number of defect descriptors.

TABLE 14.2.1-5. DEFECT LIST HEADER (4 Bytes)

BIT BYTE(S)	7	6	5	4	3	2	1	0
0	0	0	0	0	0	0	0	0
1	FOV [1]	DPY [2]	DCRT [3]	STPF [4]	0	0	0	0
2	DEFECT LIST LENGTH (MSB)					[5]		
3	DEFECT LIST LENGTH (LSB)					[5]		

DEFECT DESCRIPTORS

0-n	DEFECT DESCRIPTOR BYTES (Refer to Table 14.2.1-6a or Table 14.2.1-6b for Format)
-----	---

TABLE 14.2.1-6a. DEFECT DESCRIPTOR BYTES - BYTES FROM INDEX FORMAT

0	Cylinder Number of Defect (MSB)
1	Cylinder Number of Defect
2	Cylinder Number of Defect (LSB)
3	Head Number of Defect
4	Defect Bytes from Index (MSB)
5	Defect Bytes from Index
6	Defect Bytes from Index
7	Defect Bytes from Index (LSB)

NOTES: Definitions follow Table 14.2.1-6b.

14.2.1.2 continued

For defects to be specified in the Bytes from Index format, the defect list format field must be 100 (binary), see Tables 14.2.1-3 and 14.2.1-4.

Each Defect Descriptor for the Bytes from Index format specifies the beginning of an eight bit (1 byte) defect location on the medium. Each defect descriptor is comprised of the cylinder number of the defect, the head number of the defect and the number of bytes from Index to the defect location. (Defect bytes from Index)

The Defect Descriptors shall be in ascending order. For determining ascending order, the Cylinder Number of Defect is considered the most significant part of the address and the Defect Bytes from Index is considered the least significant part of the address.

A value for Defect Bytes from Index of FFFFFFFFH (i.e., reassign the entire track) is illegal for a WREN V.

TABLE 14.2.1-6b. DEFECT DESCRIPTOR BYTES - PHYSICAL SECTOR FORMAT

0	Cylinder Number of Defect (MSB)
1	Cylinder Number of Defect
2	Cylinder Number of Defect (LSB)
3	Head Number of Defect
4	Defect Sector Number (MSB)
5	Defect Sector Number
6	Defect Sector Number
7	Defect Sector Number (LSB)

Information in this Table is repeated for each defect.

For defects to be specified in the Physical Sector format, the Defect List format field must be 101 (binary). See Tables 14.2.1-3 and 14.2.1-4.

Each Defect Descriptor for the Physical Sector format specifies a sector size defect location comprised of the cylinder number of the defect, the head number of the defect and the defect sector number.

14.2.1.2 continued

The Defect Descriptors shall be in ascending order. For determining ascending order, the Cylinder Number of the defect is considered the most significant part of the address and the Defect Sector Number is considered the least significant part of the address.

A Defect Sector Number of FFFFFFFF (i.e., reassign the entire track) is illegal for the WREN V.

Notes for Table 14.2.1-5. Defect List Header Bit Interpretations (continued)

NOTES:FUNCTION WREN V DEFECT LIST HEADER BIT INTERPRETATIONS

- [1] FOV If one, WREN V interprets the DPRY, DCRT and STFP bits. If zero, WREN V will check the DPRY, DCRT and STFP bits for zeros.
- [2] DPRY If one, flaws in the WREN V P list will not be reallocated during formatting. This means existing reallocations of the P list will be cancelled and no new reallocations made during formatting. The P list is retained.
- If zero, flaws in the WREN V P list will be reallocated during formatting. A Check Condition shall be sent in the status if the P list cannot be found by the WREN V.
- [3] DCRT If one, WREN V will not perform a verify function during formatting (thus no C list for this format will be created or reallocated).
- If zero, WREN V will perform a verify function during formatting and will reallocate any sector which fails the verify (i.e.; a C list will be created and these flaws reallocated).
- [4] STPF If one, formatting will be terminated if an error is encountered while accessing either the P or G defect list.
- If zero, formatting will not be terminated if an error is encountered while accessing either the P or G defect list.
- [5] DEFECT The length of any following D list (Defect
LIST Descriptors) must equal to 8 times the number of
LENGTH sectors to be reallocated per Table 14.2.1-6a or Table
 14.2.1-6b.

14.2.1.2 continued

NOTE: The initiator may not use any previously defined "C", "G", or "D" lists if the sector size (block length) has been changed.

For systems which support disconnection, WREN V will disconnect while executing the Format Unit command.

14.2.1.3 Reassign Blocks Command (07H)

TABLE 14.2.1-7. REASSIGN BLOCKS COMMAND

BIT BYTE(S)	7	6	5	4	3	2	1	0
0	0	0	0	0	0	1	1	1
1	LOGICAL UNIT NO.							
	0	0	0	0	0	0	0	0
2	0	0	0	0	0	0	0	0
3	0	0	0	0	0	0	0	0
4	0	0	0	0	0	0	0	0
5	0	0	0	0	0	0	FLAG	LINK
							0	0

The Reassign Blocks command (Table 14.2.1-7) requests the target to reassign the defective logical blocks to an area on the logical unit reserved for this purpose. For a WREN V, the Logical Unit number must be zero and the Flag and Link bits must be zero.

After sending the Reassign Blocks command, the initiator transfers a defect list which contains the logical block addresses to be reassigned. The WREN V shall reassign the physical medium used for each logical block address in the list. The data contained in the logical blocks specified in the defect list will not be preserved, but the data in all other logical blocks on the medium shall be preserved. It is recommended that the initiator recover the data from the logical block(s) to be reassigned before issuing this command. After completion of this command, the initiator can write the recovered data to the same Logical Block Address(es).

14.2.1.3 continued

The effect of specifying a logical block to be reassigned that has previously been reassigned is to reassign the block again. Thus, over the life of the medium, a logical block can be assigned to multiple physical addresses (until no more spare locations remain on the medium).

This command should be used by an initiator to immediately reallocate any block (sector) which requires the WREN V to recover data by data correction via ECC if the automatic reallocation feature of the WREN V is not enabled, see Mode Select command (Section 14.2.1.7).

For systems which support disconnection, WREN V will disconnect while executing this command.

The Reassign Blocks defect list (Table 14.2.1-8) contains a four byte header followed by one or more Defect Descriptors. The length of each Defect Descriptor is four bytes.

TABLE 14.2.1-8. REASSIGN BLOCKS DEFECT LIST

DEFECT LIST HEADER								
BIT	7	6	5	4	3	2	1	0
BYTE								
0	0	0	0	0	0	0	0	0
1	0	0	0	0	0	0	0	0
2	DEFECT LIST LENGTH (MSB)							
3	DEFECT LIST LENGTH (LSB)							
DEFECT DESCRIPTOR(S)								
0	DEFECT LOGICAL BLOCK ADDRESS (MSB)							
1	DEFECT LOGICAL BLOCK ADDRESS							
2	DEFECT LOGICAL BLOCK ADDRESS							
3	DEFECT LOGICAL BLOCK ADDRESS (LSB)							

The Defect List Length specifies the total length in bytes of the Defect Descriptors that follow. The Defect List Length is equal to four times the number of Defect Descriptors.

14.2.1.3 continued

The Defect Descriptor specifies a four byte Defect Logical Block Address that contains the defect. The Defect Descriptors shall be in ascending order.

If the logical unit has insufficient capacity to reassign all of the defective logical blocks, the command shall terminate with a Check Condition status and the Sense Key shall be set to Medium Error. The logical block address of the first logical block not reassigned shall be returned in the information bytes of the sense data.

14.2.1.4 Read Command (08H)

TABLE 14.2.1-9. READ COMMAND

BIT	7	6	5	4	3	2	1	0
0	0	0	0	0	1	0	0	0
1	LOGICAL UNIT NO.			LOGICAL BLOCK ADDRESS (MSB)				
	0	0	0					
2	LOGICAL BLOCK ADDRESS							
3	LOGICAL BLOCK ADDRESS (LSB)							
4	TRANSFER LENGTH							
5	0	0	0	0	0	0	FLAG	LINK
							0	0

The Read Command (Table 14.2.1-9) requests that the WREN V transfer data to the initiator.

The Logical Block Address specifies that logical block at which the read operation shall begin.

In the CDB the LUN must be zero and the Flag and Link bits must be zero.

The Transfer Length specifies the number of contiguous logical blocks of data to be transferred. A Transfer Length of zero indicates that 256 logical blocks shall be transferred. Any other value indicates the number of logical blocks that shall be transferred.

The data value most recently written in the addressed logical block shall be returned.

14.2.1.4 continued

Read data transfers with the initiator will not begin until at least one full sector of data is available in the WREN V data buffer. For multiple sector reads, the transfer of data will continue until the number of blocks specified in byte 4 of the CDB has been read and transferred or until an unrecoverable error is detected.

Data transfer could stop if the option to stop on recovered error is selected.

For systems which support disconnection, WREN V will disconnect when a valid Read command is received by the WREN V. WREN V will reconnect depending on the value of the Buffer Full Ratio Set in Page 2 of the Mode Select Data (see Section 14.2.1.7). After data transfer has been initiated with an initiator, the WREN V will not disconnect unless an internal error recovery procedure is required or the data transfer to an initiator will be interrupted for more than 1 millisecond.

The initiator must accept all data presented to the initiator after sending this command until the WREN V sends Completion Status during a Status phase. (Note the WREN V may disconnect and reconnect while executing this command and the initiator may prematurely terminate this command by creating the Reset condition or by sending an Abort or Bus Device Reset message).

Sense Data will be valid after this command is executed and Completion Status is sent. If the Address Valid bit in the Sense Data is true (1), the Sense Data Logical Block Address (Information bytes) will point to the last Logical Block accessed by the WREN V. If the Address Valid bit in the Sense Data is false (0), the Sense Data Logical Block Address bytes are not valid.

The WREN V contains a track buffer and implements an optional "read look" ahead function whereby all data from the starting Logical Block Address to the end of the physical track is read into the buffer regardless of the transfer length in the CDB specified. This data is available for subsequent sequential disk reads without having to access the disk medium for increased performance.

This command shall be terminated with a Reservation Conflict status if any reservation access conflict (see Section 14.2.1.8) exists and no data shall be read.

14.2.1.4 continued

If any of the following conditions occur, this command shall be terminated with a Check Condition status, and if extended sense is implemented, the Sense Key shall be set as indicated in the following table. This table does not provide an exhaustive enumeration of all conditions that may cause the Check Condition status.

<u>CONDITION</u>	<u>SENSE KEY</u>
Invalid Logical Block Address	Illegal Request (see note)
Target reset since last command from this initiator	Unit Attention
Unrecoverable read error	Medium Error
Recovered read error	Recovered Error
Overrun or other error that might be resolved by repeating the command	Aborted Command

NOTE: The extended sense Information Bytes shall be set to the Logical Block Address of the first invalid address.

14.2.1.5 Write Command (OAH)

TABLE 14.2.1-10. WRITE COMMAND

BIT	7	6	5	4	3	2	1	0
BYTE(S)	0	0	0	0	1	0	1	0
1	LOGICAL UNIT NO.			LOGICAL BLOCK ADDRESS (MSB)				
	0	0	0					
2	LOGICAL BLOCK ADDRESS							
3	LOGICAL BLOCK ADDRESS (LSB)							
4	TRANSFER LENGTH							
5	0	0	0	0	0	0	FLAG	LINK
							0	0

The Write command (Table 14.2.1-10) requests that the WREN V write, to the medium, the data transferred by the initiator.

The Logical Block Address specifies the logical block at which the write operation shall begin.

14.2.1.5 continued

The Transfer Length specifies the number of contiguous logical blocks of data to be transferred. A Transfer Length of zero indicates that 256 logical blocks shall be transferred. Any other value indicates the number of logical blocks that shall be transferred.

In the CDB the LUN must be zero and the Flag and Link bits must be zero.

For a valid Write command WREN V initiates requests for write data before disconnecting and before initiating any required seek function specified for this command.

For systems which support disconnection, WREN V will disconnect when any internal error recovery procedure is required, or the data transfer with the initiator will be interrupted for more than 1 millisecond, or if the WREN V's internal data buffer is full. After a disconnect the WREN V will reconnect depending on the value of the Buffer Empty Ratio in Page 2 of Mode Select Data (see Section 14.2.1.7).

The initiator must send requested write data to the drive until the drive sends Completion status during a Status phase or until the initiator Resets/Aborts the command. (Note: the drive may disconnect and reconnect while executing this command).

Sense Data will be valid after this command is executed and Completion status is sent. (refer to the Read Command description in Section 14.2.1.4).

This command shall be terminated with a Reservation Conflict status if any reservation access conflict (see Section 14.2.1.8) exists and no data shall be written.

If any of the following conditions occur, this command shall be terminated with a Check Condition status, and if extended sense is implemented, the Sense Key shall be set as indicated in the following table. This table does not provide an exhaustive enumeration of all conditions that may cause the Check Condition status.

14.2.1.5 continued

<u>CONDITION</u>	<u>SENSE KEY</u>
Invalid Logical Block Address	Illegal Request (see note)
Target reset since last command from this initiator	Unit Attention
Overrun or other error that might be resolved by repeating the command	Aborted Command

NOTE: The extended sense Information Bytes shall be set to the Logical Block Address of the first invalid address. In this case, no data shall be written on the logical unit.

14.2.1.6 Seek Command (OBH)

TABLE 14.2.1-11. SEEK COMMAND

BIT	7	6	5	4	3	2	1	0
BYTE(S)								
0	0	0	0	0	1	0	1	1
1	LOGICAL UNIT NO.			LOGICAL BLOCK ADDRESS (MSB)				
	0	0	0					
2	LOGICAL BLOCK ADDRESS							
3	LOGICAL BLOCK ADDRESS (LSB)							
4	0	0	0	0	0	0	0	0
5	0	0	0	0	0	0	FLAG	LINK
							0	0

The Seek command (Table 14.2.1-11) requests that the WREN V seek to the specified logical block address.

For WREN V, the Logical Unit number is zero and the Flag and Link bits are zero.

The use of this command is infrequent since all commands involving data transfer to/from the WREN V media contain implied seek addresses.

14.2.1.6 continued

For systems which support disconnection, the WREN V will disconnect when a valid Seek command is received.

The maximum Logical Block Address that may be specified for a Seek command is defined in Read Capacity Data, Section 14.2.2.1.

14.2.1.7 Mode Select Command (15H)

TABLE 14.2.1-12. MODE SELECT COMMAND

BIT	7	6	5	4	3	2	1	0
0	0	0	0	1	0	1	0	1
1	LOGICAL UNIT NO.			PF				SMP
	0	0	0		0	0	0	0
2	0	0	0	0	0	0	0	0
3	0	0	0	0	0	0	0	0
4	PARAMETER LIST LENGTH							
5							FLAG	LINK
	0	0	0	0	0	0	0	0

The Mode Select command (Table 14.2.1-12) provides a means for the initiator to specify medium, logical unit, or peripheral device parameters to the WREN V. For a WREN V, the Logical Unit number must be zero and the Flag and Link bits must be zero.

The Page Format (PF) bit, when set to one, indicates the data sent by the initiator after the mode select Header and Block Descriptors (if any) complies with the Page Format. The PF bit, when set to zero, indicates the data sent after the Mode Select Header and the Block Descriptors (if any) are vendor unique. The WREN V will always interpret the PF bit to a one.

14.2.1.7 continued

The Save Mode Parameters (SMP) bit, when set to one, requests that the WREN V save the savable pages. Pages 3 and 4 may be stored only during Format commands, so they cannot be saved via a Mode Select command. The WREN V must update the Current mode values with parameters included with this command, save the Current values of the savable parameters, and report Good status only after the save operation is completed. The Saved parameters shall not be changed if an error is detected during the Mode Select command. When the SMP bit is set to zero, the Saved parameter values will not be changed.

The Parameter List Length specifies the length in bytes of the Mode Select parameter list that shall be transferred during the Data Out phase. A Parameter List Length of zero indicates that no data shall be transferred. This condition shall not be considered as an error. See Table 14.2.1-15 to determine the List Length.

A list length other than those shown in Table 14.2.1-15 (except zero) is considered an error by the WREN V.

The Mode Select parameter list (Table 14.2.1-13) contains a four byte header, followed by zero or one block descriptor, followed by the pages of Mode Select Parameters.

Acceptable values for the Mode Select parameter list for the WREN V drive are shown in Table 14.2.1-13.

14.2.1.7 continued

TABLE 14.2.1-13. MODE SELECT PARAMETER LIST

BIT BYTE(S)	7	6	5	4	3	2	1	0
	RESERVED							
0	0	0	0	0	0	0	0	0
1	MEDIUM TYPE							
	0	0	0	0	0	0	0	0
2	RESERVED							
	0	0	0	0	0	0	0	0
3	BLOCK DESCRIPTOR LENGTH EITHER 0 OR 8 (DECIMAL)							
BLOCK DESCRIPTOR								
0	DENSITY CODE							
	0	0	0	0	0	0	0	0
1	NUMBER OF BLOCKS (MSB)							
	0	0	0	0	0	0	0	0
2	NUMBER OF BLOCKS							
	0	0	0	0	0	0	0	0
3	NUMBER OF BLOCKS (LSB)							
	0	0	0	0	0	0	0	0 [1]
4	0	0	0	0	0	0	0	0
5	BLOCK LENGTH (MSB)							
6	BLOCK LENGTH [2]							
7	BLOCK LENGTH (LSB)							
PARAMETER INFORMATION								[3]
8 - n	MODE SELECT PAGE HEADERS AND THEIR PARAMETERS (TABLE 14.2.1-15)							

- NOTES: [1] All zeros to signify only one block size for the entire LUN.
 [2] Set to desired sector size before a Format. (Valid values are 256 to 4096.)
 [3] See Mode Sense Command.

14.2.1.7 continued

The medium type field shall be 00H to define the default type direct access device.

The Block Descriptor Length specifies the length in byte of the Block Descriptor. It is equal to the number of bytes in the Block Descriptor (either 0 or 8) and does not include the page headers and mode parameters. A Block Descriptor Length of zero indicates that no block descriptor shall be included in the parameter list.

Each Block Descriptor specifies the medium characteristics for all or part of a logical unit. Each Block Descriptor contains a Density Code, a Number of Blocks and a Block Length.

The Density Code shall be 00H to define the default density of medium.

The Number of Blocks field specifies the number of logical blocks on the medium that corresponds to the Density Code and Block Length in the Block Descriptor. For a WREN V, there is only one Block Descriptor, thus the Number of Blocks must be zero signifying that all logical blocks of the logical unit shall have the medium characteristics specified by the Block Descriptor.

The Block Length specifies the length in bytes of each logical block described by the Block Descriptor.

The rest of the Mode Select parameters are organized into pages that group the parameters by function. The parameter definitions are the same as those described in the Mode Sense command (paragraph 14.2.1.10) and will not be repeated here.

TABLE 14.2.1-14. MODE SELECT PAGE DESCRIPTOR HEADER

BIT	7	6	5	4	3	2	1	0
BYTE								
0	0	0	PAGE CODE					
1	PAGE LENGTH							
2-n	MODE PARAMETERS							

Each page of mode parameters begins with a two byte Page Descriptor Header. The Page Code identifies which page of mode parameters is being transferred. The Page Length indicates the number of additional bytes of mode parameters contained in this page. The number of additional bytes sent must always match the Page Length value.

14.2.1.7 continued

The WREN V only verifies Mode Select Data that is defined as changeable by the drive. The WREN V supports the following Page Codes:

<u>Page Code</u>	<u>Description</u>
01H	Error Recovery parameters
02H	Disconnect/Reconnect Control parameters
03H	Format parameters
04H	Rigid Disk Drive Geometry parameters
38H	Cache Control Parameters

The initiator shall issue a Mode Sense command requesting the WREN V to return all pages with changeable values (see PCF field description for Mode Sense command) before issuing any Mode Select commands. This allows the initiator to correctly determine which pages are supported, the proper length for those pages, and which parameters in those pages may be changed for that Logical Unit Number.

Table 14.2.1-15 summarizes the number of bytes and changeability status of the Mode Select parameter list for the WREN V. The detail information can be obtained by issuing the Mode Sense command requesting changeable values as previously discussed.

TABLE 14.2.1-15. TABLE TO DETERMINE PARAMETER LIST LENGTH

<u>FUNCTION</u>	<u>NUMBER OF BYTES (Decimal) [1]</u>	<u>CHANGEABLE BY AN INITIATOR</u>
Mode Select Header	4	NO
Block Descriptor	8 or 0	SOME
Error Recovery Page Header	2	NO
Error Recovery Page Parameters	6	SOME
Disconnect/Reconnect Page Header	2	NO
Disconnect/Reconnect Parameters	10	SOME
Format Page Header	2	NO
Format Page Parameters	22	SOME
Rigid Disk Drive Geometry Header	2	NO
Rigid Disk Drive Geometry Parameters	18	NO
Cache Control Header	2	NO
Cache Control Parameters	14	SOME

[1] Derive Parameter List Length in Table 14.2.1-12 from these numbers.

14.2.1.8 Reserve Command (16H)

TABLE 14.2.1-16. RESERVE COMMAND CDB SETUP

BIT BYTE(S)	7	6	5	4	3	2	1	0
0	0	0	0	1	0	1	1	0
1	LOGICAL UNIT NO.		3rd PRTY	0 0 or 1 [1]	3rd PRTY DEV. ID		[1]	EXTENT 0
2	RESERVATION IDENTIFICATION							
	0	0	0	0	0	0	0	0
3	EXTENT LIST LENGTH (MSB)							
	0	0	0	0	0	0	0	0
4	EXTENT LIST LENGTH (LSB)							
	0	0	0	0	0	0	0	0
5							FLAG	LINK
	0	0	0	0	0	0	0	0

[1] If bit 4 is zero, bits 3, 2, and 1 are zeros. If bit 4 is one, bits 3, 2, and 1 identify the SCSI device ID for which the drive is to be reserved.

The Reserve command (Table 14.2.1-16) is used to reserve logical units. If the third party reservation option is implemented, the logical unit may be reserved for another specified SCSI device. The Reserve and Release commands provide the basic mechanism for contention resolution in multiple initiator systems.

This command is implemented by WREN V for an Entire Unit Reserve with Third Party Reserve supported and with the WREN V specific parameters shown in Table 14.2.1-16.

14.2.1.8.1 Logical Unit Reservation

If the Extent bit is zero, this command shall request the entire logical unit (WREN V drive) be reserved for exclusive use of the initiator until the reservation is superseded by another valid Reserve command from the initiator that made the reservation, released by a Release command from the same initiator, by a Bus Device Reset message from any initiator, or by a "hard" Reset condition. A logical unit reservation shall not be granted if any extent or logical unit is reserved by another initiator or if any extent with a read shared reservation type is reserved by this initiator. It shall be permissible for an initiator to reserve a logical unit that is currently reserved by that initiator. If the Extent bit is zero, the Reservation Identification and the Extent List Length shall be ignored. If the Extent bit is a one, the WREN V will generate Check Condition status and set the sense key to illegal request.

If, after honoring the reservation, any other initiator subsequently attempts to perform a command other than a Release command, which shall be ignored, or an Inquiry command, which shall be executed, or a Request Sense command, which shall be executed, the command shall be rejected with Reservation Conflict status.

14.2.1.8.2 Extent Reservation

WREN V does not support Extent reservations. This bit must always be zero. Since the Reservation Identification byte and the Extent List Length are valid only for extent reservations, WREN V will ignore these fields.

14.2.1.8.3 Third Party Reservation

WREN V supports the third party reservation option. The third party reservation option for the Reserve command allows an initiator to reserve a logical unit for another SCSI device. This option is intended for use in multiple initiator systems which use the Copy command. WREN V shall also implement the third party release option (see Section 14.2.1.9.3).

If the third party (3rdPty) bit is zero, then the third party reservation option is not requested. If the 3rdPty bit is one the Reserve command shall reserve the specified logical unit for the SCSI device specified in the third party device ID field. The WREN V shall preserve the reservation until it is superseded by another valid Reserve command from the initiator which made the reservation or until it is released by the same initiator, by a Bus Device Reset message from any initiator, or a "hard" Reset condition. The WREN V shall ignore any attempt to release the reservation made by any other initiator.

14.2.1.8.4 Superseding Reservations

An initiator which holds a current reservation may modify that reservation by issuing another Reserve command to the same logical unit. The superseding Reserve command shall release the previous reservation state when the new reservation request is granted. The previous reservation shall not be modified if the new reservation request cannot be granted.

Implementors Note: Superseding reservations are principally intended to allow the SCSI device ID to be changed on a reservation using third party reservation option. This capability is necessary for certain situations when using the Copy command.

14.2.1.9 Release Command (17H)

TABLE 14.2.1-17. RELEASE COMMAND

BIT BYTE(S)	7	6	5	4	3	2	1	0
0	0	0	0	1	0	1	1	1
1	LOGICAL UNIT NO.		3rd[1]	THIRD PRY DEV. ID.		EXTENT		
	0	0	0	PRTY	[1]			0
			0 or 1					
2	RESERVATION IDENTIFICATION							
	0	0	0	0	0	0	0	0
3	EXTENT LIST LENGTH (MSB)							
	0	0	0	0	0	0	0	0
4	EXTENT LIST LENGTH (LSB)							
	0	0	0	0	0	0	0	0
5							FLAG	LINK
	0	0	0	0	0	0	0	0

[1] Same as Note 1 for Reserve Command, Section 14.2.1.8.

The Release command (Table 14.2.1-17) is used to release previously reserved logical units. It is not an error for an initiator to attempt to release a reservation that is not currently active. In this case, the target returns Good status without altering any other reservation.

The command is implemented by WREN V for an Entire Unit Release and Third Party Release supported with the WREN V specific parameters listed in Table 14.2.1-17.

In the CDB the LUN must be zero, and the Extent, Flag and Link bits must be zero.

14.2.1.9.1 Logical Unit Release

If the extent bit is zero, the Release command shall cause the WREN V to terminate all reservations from the initiator to the WREN V.

14.2.1.9.2 Extent Release

The WREN V does not support extent reservations. This bit must always be zero. Since the Reservation Identification byte is valid only for extent reservations, WREN V will ignore this byte.

14.2.1.9.3 Third Party Release

WREN V supports the third party release option. The third party release option for the Release command allows an initiator to release a logical unit which was previously reserved using the third party reservation option (see Section 14.2.1.8.3). This option is intended for use in multiple initiator systems which use the Copy command.

If the third party (3rdPty) bit is zero, the third party release option is not requested. If the 3rdPty bit is one, the WREN V shall release the specified logical unit, but only if the reservation was made using the third party reservation option by the initiator that is requesting the release, and for the same SCSI device specified in the third party ID field.

14.2.1.10 Mode Sense Command (1AH)

TABLE 14.2.1-18. MODE SENSE COMMAND

BIT BYTE(S)	7	6	5	4	3	2	1	0
0	0	0	0	1	1	0	1	0
1	LOGICAL UNIT NO.			0	0	0	0	0
2	PCF (See Table 14.2.1-19)		PAGE CODE (See Table 14.2.1-20)					
3	0	0	0	0	0	0	0	0
4	ALLOCATION LENGTH (See Table 14.2.1-20)							
5	0	0	0	0	0	0	FLAG 0	LINK 0

The Mode Sense command provides a means for a WREN V to report it's medium, logical unit, or peripheral device parameters to the initiator. It is a command complementary to the Mode Select command for support of medium that may contain multiple block lengths or densities.

This command is implemented in WREN V with the following drive specific parameters:

14.2.1.10 continued

CDB Specification

The LUN must be zero, and the Flag and Link bits must be zero. See Table 14.2.1-18.

The content of Mode Parameter bytes is determined by the value of the PCF (Page Control Field) bits specified in CDB byte 2, bits 6 & 7. The WREN V shall return the same Page Length for each supported page regardless of the value of PCF. The PCF field is defined in Table 14.2.1-19.

TABLE 14.2.1-19. PAGE CONTROL FIELD BITS AFFECT ON MODE PARAMETERS RETURNED

<u>PCF BIT</u>		
<u>7</u>	<u>6</u>	
0	0	Return Current values. The Current values are the values currently being used by the WREN V to control it's operation. After a Power On Reset, a hard Reset, or a Bus Device Reset message the Current values will be equal to the Saved values (if Saved values can be retrieved) or the Default values (if Saved values cannot be retrieved). The Current value of a parameter is updated whenever a Mode Select command which changes that parameter ends with Good status being returned.
0	1	Return Changeable values. The changeable values of any page is a mask that indicates which parameters may be changed via a Mode Select command and which parameters may not. Each returned parameter byte shall contain ones where a field or bit may be changed and zeros where a field or bit may not be changed.
1	0	Return Default values. The Default values are the values to which the WREN V will set the Current values after a reset condition unless valid Saved values are available.
1	1	Return Saved values. The saved values are the values the WREN V stores in nonvolatile memory. The Saved values of any changeable parameter can be set via a Mode Select command. For nonchangeable parameters, the Default value will be used.

The Block descriptor will contain it's normal values regardless of the value of the PCF. Unsupported fields or bits within a page will be returned as zeros for all PCF values.

14.2.1.10 continued

The Page Code allows the initiator to select one or all of the pages of Mode parameters supported by the target. Page Codes which are supported by WREN V are summarized here (see Table 14.2.1-20):

<u>Page Code</u>	<u>Description</u>
00H	Product Unique. Not used. If received, the WREN V will only return the four byte header and 8 byte block descriptor.
01H	Error Recovery parameters.
02H	Disconnect/Reconnect Control parameters.
03H	Format parameters.
04H	Rigid Disk Drive Geometry parameters.
05H - 37H	Not used.
038H	Cache Control Parameters
39H-3EH	Not used.
3FH	Return all supported pages.

The Allocation Length specifies the number of bytes that the initiator has allocated for returned Mode Sense data. An Allocation Length of zero indicates that no Mode Sense data shall be transferred. This condition shall not be considered as an error. Any other value indicates the maximum number of bytes that shall be transferred. The WREN V shall terminate the Data In phase when allocation length bytes have been transferred or when all available Mode Sense data has been transferred to the initiator, whichever is less.

The Mode Sense data (Table 14.2.1-21) will always include a four byte header, followed by one eight byte block descriptor, followed by the requested page or pages of Mode Sense parameters.

WREN V supports the following page codes. The Allocation Length should be at least the value in Table 14.2.1-20 for the initiator to receive all of the possible available information for this page code.

14.2.1.10 continued

TABLE 14.2.1-20. MODE SENSE CDB SETUP

<u>CDB PAGE CODE</u>	<u>LENGTH (DECIMAL)</u>	<u>MODE SENSE "DATA" RETURNED</u>
(CDB Byte 2, Bits 5-0)		
00H	12	4 bytes of Mode Sense Header and 8 bytes of Block Descriptor Data
01H	20	4 bytes of Mode Sense Header 8 bytes of Block Descriptor Data 2 bytes of Error Recovery Header 6 bytes of Error Recovery Parameters [1]
02H	24	4 bytes of Mode Sense Header 8 bytes of Block Descriptor Data 2 bytes of Disconnect/Reconnect Control Header 10 bytes of Disconnect/Reconnect Control Parameters [1]
03H	36	4 bytes of Mode Sense Header 8 bytes of Block Descriptor Data 2 bytes of Format Control Header 22 bytes of Format Parameters [1]
04H	32	4 bytes of Mode Sense Header 8 bytes of Block Descriptor Data 2 bytes of Rigid Disk Drive Geometry Header [1] 18 bytes of Rigid Disk Drive Geometry Parameters
38H	28	4 bytes of Mode Sense Header 8 bytes of Block Descriptor Data 2 bytes of Cache Control Parameter Page Header 14 bytes of Cache Control Parameter Data [1]
3FH	92	4 bytes of Mode Sense Header 8 bytes of Block Descriptor Data 80 bytes of Headers and parameter data for 01H, 02H 03H 04H and 38H Page Codes. [1]

[1] See PCF description for Mode Sense CDB (Table 14.2.1-18).

WREN V returned values of Mode Sense Header and Block Descriptor Data are defined in Table 14.2.1-21.

(2445P)

14.2.1.10 continued

TABLE 14.2.1-21. MODE SENSE DATA

BIT BYTE(S)	7	6	5	4	3	2	1	0	
0	SENSE DATA LENGTH "LENGTH" ENTRY OF TABLE 14.2.1-20 MINUS ONE [1]								
1	0	0	0	0	0	0	0	0	[2]
2	WP 0[3]	0	0	0	0	0	0	0	
3	BLOCK DESCRIPTOR LENGTH (8 decimal) 0 0 0 0 1 0 0 0 [4]								
BLOCK DESCRIPTOR DATA									
0	DENSITY CODE 0 0 0 0 0 0 0 0 [5]								
1	NUMBER OF BLOCKS (MSB) 0 0 0 0 0 0 0 0 [6]								
2	NUMBER OF BLOCKS 0 0 0 0 0 0 0 0 [6]								
3	NUMBER OF BLOCKS (LSB) 0 0 0 0 0 0 0 0 [6]								
4	RESERVED 0 0 0 0 0 0 0 0								
5	BLOCK LENGTH (MSB) [7]								
6	BLOCK LENGTH [7]								
7	BLOCK LENGTH (LSB) [7]								
PARAMETER INFORMATION									
0-n	MODE SENSE PAGE HEADERS AND THEIR PARAMETERS (See Table 14.2.1-22)								

See following page for notes.

14.2.1.10 continued

Notes for Table 14.2.1-21 Mode Sense Data (continued)

- [1] The Sense Data Length specifies the length in bytes of the following Mode Sense data that is available to be transferred during the Data In phase. The Sense Data Length does not include itself.
- [2] WREN V supports only OOH (default medium) in the Medium Type field.
- [3] A Write Protect (WP) bit of zero indicates the medium is write enabled. A WP bit of one indicates the medium is write protected. The WREN V will always return a zero in this bit.
- [4] The Block Descriptor Length specifies the length in bytes of the Block Descriptor. It is equal to the number of bytes in the Block Descriptor (8) and does not include the page headers and mode parameters, if any. WREN V will send one Block Descriptor.

Each Block Descriptor specifies the medium characteristics for all or part of a logical unit. Each Block Descriptor contains a Density Code, a Number of Blocks, and a Block Length.
- [5] WREN V supports only OOH (default density) in the Density Code field.
- [6] The Number of Blocks field specifies the number of logical blocks of the medium that meets the Density Code and Block Length in the Block Descriptor. A Number of Blocks of zero indicates that all of the remaining logical blocks of the logical unit have the medium characteristics specified by the Block Descriptor. The WREN V will always return zeros in the Number of Blocks field.
- [7] The Block Length, as defined after a format function, specifies the length in bytes of each logical block described by the Block Descriptor. Default is 512 if no Mode Select command is received before the Format command. Valid values are 256 through 4096.

14.2.1.10 continued

Mode Sense Page Descriptor Header

TABLE 14.2.1-22. MODE SENSE PAGE DESCRIPTOR HEADER

BIT BYTE(S)	7	6	5	4	3	2	1	0
0	PS 0 or 1	0	PAGE CODE					[1]
1	PAGE LENGTH						[1]	
2-n	MODE PARAMETERS						[1]	

[1]	<u>PAGE CODE</u>	<u>PAGE DESCRIPTION</u>	<u>REFERENCE TABLE</u>
	01	Error Recovery	14.2.1-23
	02	Disconnect/Reconnect Control	14.2.1-24
	03	Format Parameters	14.2.1-25
	04	Rigid Disk Drive Geometry	14.2.1-26
	38	Cache Control Parameters	14.2.1-27

Each page of mode parameters (for the Mode Sense command) begins with a two byte Page Descriptor Header. The Page Code identifies which page of mode parameters is being transferred. The Page Length indicates the number of additional bytes of mode parameters being sent by the WREN V. Multiple pages of mode parameters may be transferred in one Mode Sense Data In phase (using Page Code 3FH).

The Parameters Savable (PS) bit, when set to one, indicates if the page contains savable parameters. When the PS bit is set to zero, none of the parameters within the page are savable. Since the parameters within pages 3 and 4 will always be saved during Format commands (but not via a Mode Select command with the SMP bit set to 1), these pages will return a one for the PS bit.

Error Recovery Page

WREN V Error Recovery Page implementation is defined in Table 14.2.1-23. This table summarizes: the function, the default value, and changeability status for each byte/bit.

14.2.1.10 continued

TABLE 14.2.1-23. ERROR RECOVERY PAGE

PAGE DESCRIPTOR HEADER									
BIT	7	6	5	4	3	2	1	0	
0	PS								
	1[1]	0	0	0	0	0	0	0	1
PAGE CODE (1 Decimal)									
1									
	0	0	0	0	0	1	1	0	
PAGE LENGTH (BYTES) - 6 Decimal									
ERROR RECOVERY PARAMETERS									
2	AWRE	ARRE	TB	RC	EEC	PER	DTE	DCR	
DEFAULT	0	0	0	0	0	0	0	0	[3]
CHANGE-ABLE [2]	1	1	1	1	1	1	1	1	
3	RETRY COUNT								
DEFAULT	0	0	0	1	1	0	1	1	27 Decimal
CHANGE-ABLE [2]	1	1	1	1	1	1	1	1	[4]
4	CORRECTION SPAN (bits) - 11 Decimal								
DEFAULT	0	0	0	0	1	0	1	1	[5]
CHANGE-ABLE [2]	0	0	0	0	0	0	0	0	
5	HEAD OFFSET COUNT								
DEFAULT	0	0	0	0	0	0	0	0	[6]
CHANGE-ABLE [2]	0	0	0	0	0	0	0	0	
6	DATA STROBE OFFSET COUNT								
DEFAULT	0	0	0	0	0	0	0	0	[7]
CHANGE-ABLE [2]	0	0	0	0	0	0	0	0	
7	RECOVERY TIME LIMIT								
DEFAULT	1	1	1	1	1	1	1	1	[8]
CHANGE-ABLE [2]	0	0	0	0	0	0	0	0	

See following pages for notes.

14.2.1.10 continued

Notes for Table 14.2.1-23. Error Recovery Page

- [1] The returned PS (Parameter Savable) bit of 1 indicates that page 01H parameter data is savable.
- [2] A value of zero means this bit function is not directly changeable by an initiator, a value of 1 means the bit function is directly changeable by an initiator. (See Mode Select Command)
- [3] The Automatic Write Reallocation of defective data blocks Enabled (AWRE) bit, when set to one, allows the WREN V to automatically relocate bad blocks detected during write operations. This function doesn't apply to the Format Unit command. When set to zero, the WREN V shall not perform automatic reallocation but shall create Check Condition status with Sense Key of Medium Error instead.

The Automatic Read Reallocation of defective data blocks Enabled (ARRE) bit, when set to one, allows the WREN V to automatically relocate bad blocks detected during read operations. When set to zero, the WREN V shall not perform automatic reallocation but shall create Check Condition status with Sense Key of Medium Error instead.

The Transfer Block (TB) bit, when set to one, indicates the failing data block shall be transferred to the initiator. When set to zero, the failing data block shall not be transferred.

The Read Continuous (RC) bit, when set to one, requests the WREN V to transfer the requested data length without adding delays (for retries or ECC correction) which may be required to ensure data integrity. The WREN V may send erroneous data in order to maintain the continuous flow of data. This bit shall override the DTE bit if it is set. When set to zero, recovery actions during data transfer are allowed.

The Enable Early Correction (EEC) bit, when set to one, allows the WREN V to apply ECC correction as soon as possible, before the retry count is exhausted. Seek error retries are not affected by this bit. When this bit is set, the DCR bit must be zero. When the EEC bit is set to zero, the WREN V shall exhaust the retry count before applying ECC correction.

14.2.1.10 continued

Notes for Table 14.2.1-23. Error Recovery Page (continued)

[3] continued

The Post Error (PER) bit, when set to one, indicates the WREN V will report Check Condition status and appropriate Sense Key for any recovered errors encountered. Reporting of unrecoverable errors will have priority over reporting of recoverable errors. When set to zero, any errors recovered within the limits established by the other Error Recovery Flags will not be reported. Any unrecoverable errors will be reported.

The Disable Transfer on Error (DTE) bit is valid only when the PER bit is set to one. When the DTE bit is set to one, it indicates the WREN V will terminate data transfer even for recoverable errors. The setting of the TB bit determines whether the block in error will be transferred. When DTE is set to zero, data transfer will continue if recoverable errors are encountered. If the PER bit is one and the DTE bit is zero, recoverable errors will be reported after all data has been transferred.

The Disable Correction (DCR) bit, when set to one, indicates ECC correction shall not be applied to the data even if correction is possible. When set to zero, ECC correction shall be applied if correction is possible.

[4] The Retry Count is the maximum number of times the WREN V will attempt it's read recovery algorithms. The Retry Count is changeable between 0 and 27 inclusive. A Retry Count of zero will inhibit retries from being performed. If the EEC bit is set then the number of retries specified by the Retry Count, up to a maximum of nine retries, will be performed before ECC is applied.

[5] The Correction Span is the size of the largest read data error, in bits, on which ECC correction will be attempted. Errors longer than this span (11 decimal) are reported as unrecoverable.

14.2.1.10 continued

Notes for Table 14.2.1-23. Error Recovery Page (continued)

- [6] The WREN V Head Offset Count is a default of zero and not changeable to signify that this feature is not programmable by the initiator. Head offsets will be performed as part of the WREN V's retry algorithms.
- [7] The WREN V Data Strobe Offset Count is a default of zero and not changeable to signify that this feature is not programmable by the initiator. Data Strobe Offsets will be performed as part of the WREN V's retry algorithms.
- [8] A Hex FF indicates that the Recovery Time Limit is unlimited.

Disconnect/Reconnect Control Page

The WREN V Disconnect/Reconnect Page implementation is defined in Table 14.2.1-24. This table summarizes the function and defines the default value and changeable status.

TABLE 14.2.1-24. DISCONNECT/RECONNECT CONTROL PAGE

PAGE DESCRIPTOR HEADER

BIT BYTE(S)	7	6	5	4	3	2	1	0
0	PS 1[1]	0	0	0	0	0	1	0
1	PAGE LENGTH (10 Decimal)							
	0	0	0	0	1	0	1	0

DISCONNECT/RECONNECT CONTROL PARAMETERS

2	BUFFER FULL RATIO							
DEFAULT	0	0	0	0	0	1	0	0
CHANGEABLE[2]	1	1	1	1	1	1	1	1
3	BUFFER EMPTY RATIO							
DEFAULT	0	0	0	0	0	1	0	0
CHANGEABLE[2]	1	1	1	1	1	1	1	1
4	BUS INACTIVITY LIMIT (MSB)							
DEFAULT	0	0	0	0	0	0	0	0
CHANGEABLE[2]	0	0	0	0	0	0	0	0
5	BUS INACTIVITY LIMIT (LSB) (10 Decimal)							
DEFAULT	0	0	0	0	1	0	1	0
CHANGEABLE[2]	0	0	0	0	0	0	0	0
6,7	DISCONNECT TIME UNIT							
DEFAULT	0 0 0 0 H							
CHANGEABLE[2]	0 0 0 0 H							
8,9	CONNECT TIME LIMIT							
DEFAULT	0 0 0 0 H							
CHANGEABLE[2]	0 0 0 0 H							
10,11	RESERVED							
DEFAULT[2]	0 0 0 0 H							
CHANGEABLE[2]	0 0 0 0 H							

[1] The PS (Parameter Savable) bit of 1 indicates that the page 02H parameter data is savable.

[2] A changeable value of zero means this function is not directly changeable by an initiator. A value of 1 means the bit function is directly changeable by an initiator. (See Mode Select command.)

[3] 1 millisecond

14.2.1.10 continued

Both the ratio parameters are the numerator of a fractional multiplier that has 256 as it's denominator.

The Buffer Full Ratio indicates, on Read commands, how full the WREN V's buffer shall be before reconnecting. The WREN V will round up to the nearest whole logical block. This value is changeable by an initiator.

The Buffer Empty Ratio indicates, on Write commands, how empty the WREN V's buffer shall be before reconnecting to fetch more data. The WREN V, rounds up to the nearest whole logical block. This value is changeable by an initiator.

The Bus Inactivity Limit field (bytes 4 & 5) indicates the time, in 100 microsecond increments, the WREN V is allowed to assert the Busy signal without handshakes until it shall disconnect. The WREN V may round down to it's nearest capable value. The value of ten indicates the WREN V is allowed to maintain the Busy signal for one millisecond without handshakes. This value is not changeable by the initiator.

The Disconnect Time Limit field (bytes 6 and 7) indicates the minimum time, in 100 microsecond increments, the WREN V shall remain disconnected until it shall attempt to reconnect. A value of zero indicates the WREN V is allowed to reconnect immediately. For WREN V, this is always zero and the changeable code is always zero.

The Connect Time Limit field (bytes 8 and 9) indicates the maximum time in 100 microsecond increments that the target should remain connected until it attempts to disconnect. The target may round to it's nearest capable value. A setting of zero indicates that the WREN V is allowed to remain connected indefinitely until it attempts disconnection.

Format Parameters Page

The WREN V Format Parameters Page implementation is defined in Table 14.2.1-25. This table summarizes the function and defines the default or changeability status for each bit.

14.2.1.10 continued

TABLE 14.2.1-25. FORMAT PARAMETER PAGE

PAGE DESCRIPTOR HEADER									
BIT	7	6	5	4	3	2	1	0	
BYTE(S)	PS[1]		PAGE CODE (3 Decimal)						
0	1	0	0	0	0	0	1	1	
1	PAGE LENGTH (22 Decimal)								
	0	0	0	1	0	1	1	0	
FORMAT PARAMETERS [1]									
2,3	TRACKS PER ZONE (MSB)								
DEFAULT	0 0 0 1 (HEX) [2]								
CHANGEABLE	F F F F (HEX)								
4,5	ALTERNATE SECTORS PER ZONE								
DEFAULT	0 0 0 1 (HEX) [3]								
CHANGEABLE	0 0 F F (HEX)								
6,7	ALTERNATE TRACKS PER ZONE								
DEFAULT	0 0 0 0 (HEX) [4]								
CHANGEABLE	0 0 0 0 (HEX)								
8,9	ALTERNATE TRACKS PER VOLUME								
DEFAULT	0 0 X X (HEX) [5]								
CHANGEABLE	F F F F (HEX)								
10,11	SECTORS PER TRACK								
DEFAULT	0 0 X X (HEX) [6]								
CHANGEABLE	0 0 0 0 (HEX)								
12,13	DATA BYTES PER PHYSICAL SECTOR								
DEFAULT	0 2 0 0 (HEX) [7]								
CHANGEABLE	0 0 0 0 (HEX)								
14,15	INTERLEAVE								
DEFAULT	0 0 0 1 (HEX) [8]								
CHANGEABLE	0 0 0 0 (HEX)								
16,17	TRACK SKEW FACTOR								
DEFAULT	0 0 X X (HEX) [9]								
CHANGEABLE	0 0 0 0 (HEX)								
18,19	CYLINDER SKEW FACTOR								
DEFAULT	0 0 X X (HEX) [10]								
CHANGEABLE	0 0 0 0 (HEX)								
20	DRIVE TYPE FIELD								
DEFAULT	1	0	0	0	0	0	0	0 [11]	
	SSEC	HSEC	RMB	SURF	INS	RESERVED			
CHANGEABLE	0	0	0	0	1	0	0	0	
21,22,23	RESERVED								
DEFAULT	0 0 0 0 0 0 (HEX)								
CHANGEABLE	0 0 0 0 0 0 (HEX)								

14.2.1.10 continued

Notes for Table 14.2.1-25. Format Parameter Page (continued)

- [1] This page of parameters may be sent only immediately before sending a Format Unit command to the WREN V. The Current parameters for this page will be updated immediately but any changes between these Current parameters and the existing media format will not be in effect until after the Format Unit command is completed.
- [2] The Tracks per Zone field indicates the number of tracks the WREN V will allocate to each defect management zone. The WREN V will support defining a defect management zone as one track or one cylinder. A Initiator programmed value of 1 defines one track per zone i.e. (spare sectors per track). Any other recorded value will result in the drive defining one cylinder as the defect management zone and the drive will automatically insert the number of read/write heads (i.e. number of tracks per cylinder) in this field. The Default Drive value is 1.
- [3] The Alternate Sectors per Zone field indicates the number of spare sectors to be reserved for the defined defect management zone. A value of zero indicates that no sectors are to be reserved in each zone for defect management. This is to accommodate hosts that want to manage the defects themselves. The maximum Initiator programmable value is either 255 or one less than the minimum number of sectors per track for the drives. One is a reasonable maximum if one track is defined as the defect management zone (i.e. one spare sector per track). Eight is a reasonable maximum if one cylinder is defined as the defect management zone. The Default Drive value is 1 (with [2], defines one spare sector per track).
- [4] The Alternate Tracks per Zone field indicates the number of spare tracks to be reserved at the end of each defect management zone. A value of zero indicates that no spare tracks are to be reserved in each zone for defect management by the WREN V.
- [5] The Alternate Tracks per Volume field indicates the number of spare tracks to be reserved at the end of the logical unit. The WREN V will use these locations for replacing sectors. A value of zero indicates that no spare tracks are to be reserved at the end of the unit for defect management. The WREN V defaults to two times the number of read/write heads in the drive. The initiator may change this value for any number between 0 and 255. This number must be a multiple of the number of Data Read/Write heads installed.

14.2.1.10 continued

Notes for Table 14.2.1-25. Format Parameter Page (continued)

- [6] The Sectors per Track field indicates the number of physical sectors the WREN V shall allocate per disk track. A value of zero indicates the number of sectors per track may be variable or the WREN V is to determine the best value. The WREN V will report the average number of physical sectors per track since the number of sectors per track varies between the outer and inner tracks. This field will not be verified on a Mode Select command.
- [7] The Bytes per Physical Sector field indicates the number of data bytes the WREN V shall allocate per physical sector. This value will equal the block length reported in the block descriptor. The bytes per physical sector is not directly changeable by the initiator and will not be verified on a Mode Select command.
- [8] The Interleave field is the interleave value sent to the WREN V during the last Format Unit command. This field is valid only for Mode Sense commands. The WREN V shall ignore this field during Mode Select commands.
- [9] The Track Skew Factor field indicates the average number of physical sectors between the last logical block on one track and the first logical block on the next sequential track of the same cylinder. A value of zero indicates no skew. The Default Value is 6 for 512 byte sectors. This value is not changeable by an initiator.
- [10] The Cylinder Skew Factor field indicates the average number of physical sectors between the last logical block of one cylinder and the first logical block of the next cylinder. A value of zero indicates no skew. The Default Value is 19 for 512 byte sectors. Cylinder skew will be utilized by a WREN V but is not changeable by an initiator.

14.2.1.10 continued

Notes for Table 14.2.1-25. Format Parameter Page (continued)

[11] The Drive Type field bits are defined as follows:

The Soft Sectoring (SSEC) bit (bit 7) is set to one indicating the WREN V shall use soft sector formatting.

The Inhibit Save (INS) bit (bit 3), when set to one, indicates the WREN V shall inhibit the saving of any parameters other than those contained in pages 3 or 4 during the next Format command. The preexisting values of any savable parameters will be maintained. When INS is set to zero, any savable parameters shall be updated to their Current values and saved during the next Format command. The default value is zero, but the changeable bit is one, indicating it may be changed.

The following bits are not implemented by WREN V and are always zero and changeable bits are likewise zero.

The Hard Sectoring (HSEC) bit, when set to one, indicates that the target shall use hard sector formatting. The SSEC and HSEC bits cannot both be set to one in Mode Select commands.

The Removable Media (RMB) bit, when set to one, indicates that the logical unit contains removable media. This same bit is also returned in the Inquiry parameters (see Section 14.1.1.3).

The Surface Map (SURF) bit, when set to one, indicates that the target shall allocate successive logical blocks to all sectors on a surface before allocating logical blocks to the next surface. When SURF is set to zero, the target shall allocate successive logical blocks to all sectors within a cylinder before allocating logical blocks to the next cylinder.

14.2.1.10 continued

Rigid Disk Drive Geometry Parameters

The WREN V Rigid Disk Drive Geometry Parameters Page implementation is defined in Table 14.2.1-26. This table summarizes the function and defines the default value. An initiator may not change the default values, thus the changeable status is always zero for all bytes/bits in this page.

TABLE 14.2.1-26. RIGID DISK DRIVE GEOMETRY PARAMETERS

PAGE DESCRIPTOR HEADER									
BIT	7	6	5	4	3	2	1	0	
BYTE(S)									
0	PS[1]								
	1	0	0	0	0	1	0	0	
1									
	0	0	0	1	0	0	1	0	
RIGID DISK DRIVE GEOMETRY PARAMETERS									
2									
	0	0	0	0	0	0	0	0	[2]
3									
	0	0	0	0	0	1	1	0	[2]
4									
	0	0	0	0	1	0	1	0	[2]
5									
									[3]
6,7,8									
	0	0	0	0	0	0	0	0	[4]
9,10,11									
	0	0	0	0	0	0	0	0	[4]
12,13									
	0	0	0	0	0	0	0	0	[4]
14,15,16									
	0	0	0	0	0	0	0	0	[4]
17,18,19									
	0	0	0	0	0	0	0	0	[4]

- [1] The reserved PS bit of 1 indicates that page 04 parameter data is savable and will be saved when a Format Function is performed.
- [2] 1546 user accessible cylinders maximum with no spare cylinders (tracks) set aside for flaw reallocation.
- [3] 15
- [4] Not applicable.

The following page of parameters may be sent via a Mode Select command only immediately before sending a Format Unit command to the WREN V and must equal the values reported by the Mode Sense command.

14.2.1.10 continued

The Number of Cylinders field indicates the maximum number of user available cylinders for the WREN V. The WREN V will use some of the additional cylinders available for storing WREN V parameters, defect lists, or diagnostic purposes.

The number of Heads field indicates the maximum number of data (read/write) heads on the WREN V drive.

TABLE 14.2.1-27. CACHE CONTROL PARAMETERS

BIT BYTE(S)	7	6	5	4	3	2	1	0	
0	PS 1[1]	0	1	1	1	0	0	0	
Page Code (38 Hex)									

1	PAGE LENGTH (bytes) - (14 decimal)								
	0	0	0	0	1	1	1	0	
CACHE CONTROL PARAMETERS									
2	RSVD	WIE	RSVD	CE	CACHE TABLE SIZE			[3]	
DEFAULT	0	0	0	0	0	0	0	1	

CHANGE- ABLE[2]	0	0	0	1	0	0	0	0	
3	PREFETCH THRESHOLD								[4]
DEFAULT	1	1	1	1	1	1	1	1	

CHANGE- ABLE	0	0	0	0	0	0	0	0	
4	MAXIMUM PREFETCH								[5]
DEFAULT	0	0	1	1	0	1	0	0	

CHANGE- ABLE	0	0	0	0	0	0	0	0	
5	MAXIMUM PREFETCH MULTIPLIER								[5]
DEFAULT	0	0	0	0	0	0	0	0	

CHANGE- ABLE	0	0	0	0	0	0	0	0	
6	MINIMUM PREFETCH								[6]
DEFAULT	0	0	0	0	0	0	0	0	

CHANGE- ABLE	0	0	0	0	0	0	0	0	
7	MINIMUM PREFETCH MULTIPLIER								[6]
DEFAULT	0	0	0	0	0	0	0	0	

CHANGE- ABLE	0	0	0	0	0	0	0	0	
8-15	RESERVED								
	0	0	0	0	0	0	0	0	

14.2.1.10 continued

Notes for Table 14.2.1-27 Cache Control Parameters

- [1] The PS (Parameter Savable) bit of 1 indicates that the page 38H parameter data is savable.
- [2] A changeable value of zero means this function is not directly changeable by an initiator. A value of 1 means the bit function is directly changeable by an initiator. (See Mode Select command.)
- [3] Cache Enable bit 4 of one indicates that the WREN drive will use a read look ahead algorithm on all data reads. On subsequent reads, if the data is already residing in the WREN data buffer, the data transfer commences with no latency times. If bit 4 is zero it indicates read look ahead will not be used.
- Write Index Enable bit 6 controls the creation of Cache data on Write commands. If bit 6 is a one the Write data will be treated as Cache Read data on the next command. If bit 6 is zero the next command treats the cache area as empty of data.
- Cache table size bits 3 thru 0 indicate the number of cache segments to maintain in buffer ram.
- [4] Prefetch Threshold byte 3 indicates the maximum value of the transfer length byte of the Read command for which a prefetch will be performed.
- [5] The product of the Maximum Prefetch Multiplier, byte 5, and the Read command transfer length is added to the value of the Maximum Prefetch, byte 4, to indicate the maximum number of blocks to prefetch when a Read command is issued and the blocks are not already cached.
- [6] The product of the Minimum Prefetch Multiplier, byte 7, and Read command transfer length is added to the value of the Minimum Prefetch, byte 6, to indicate the minimum number of blocks to prefetch when a Read command is issued and the blocks are not already cached.

14.2.1.11 Start Unit Command (1BH)

TABLE 14.2.1-28. START UNIT COMMAND

BIT BYTE(S)	7	6	5	4	3	2	1	0	
0	0	0	0	1	1	0	1	1	
1	LOGICAL UNIT NO.							IMMED	
	0	0	0	0	0	0	0		
2	0	0	0	0	0	0	0	0	
3	0	0	0	0	0	0	0	0	
4	0	0	0	0	0	0	0	START 1	
5	0	0	0	0	0	0	FLAG 0	LINK 0	

The Start Unit command requests that the target enable the logical unit for further operations.

An Immed bit of zero indicates that status shall be returned after the operation is completed. If the Immed bit is a one status will be returned as soon as the operation is initiated.

The Start bit must be a one. This requests that the logical unit be made ready for use. If the Start bit is zero (requesting that the unit be stopped), the command will be rejected as an illegal request.

14.2.1.11 continued

This command is applicable only if the Motor Start Option jumper is installed. See Figures 10.3-2 and 11.1-1. If this jumper is installed, the drive will only respond to the Start Unit, Inquiry and Request Sense commands. If the jumper is not installed the WREN V will respond to communications on the interface while the drive is coming up to speed.

For systems which support disconnection, WREN V will disconnect when a Start Unit procedure is commanded, and will reconnect when the unit is up to speed and Ready.

14.2.1.12 Prevent/Allow Medium Removal Command (1EH)

Not implemented by WREN V. If received, WREN V will terminate with Check Condition status and set an Illegal Request Sense Key.

14.2.2 GROUP 1 COMMAND FOR DIRECT ACCESS DEVICES

The Group 1 commands implemented by the WREN V are listed in Table 14.2.1-29.

TABLE 14.2.1-29. GROUP 1 COMMANDS FOR DIRECT ACCESS DEVICES

<u>OPERATION CODE (HEX)</u>	<u>COMMAND NAME</u>	<u>SECTION</u>
25	READ CAPACITY	14.2.2.1
28	READ EXTENDED	14.2.2.2
2A	WRITE EXTENDED	14.2.2.3
2B	SEEK EXTENDED	14.2.2.4
2F	VERIFY	14.2.2.6
37	READ DEFECT DATA	14.2.2.9
3B	WRITE DATA BUFFER	14.1.2.3
3C	READ DATA BUFFER	14.1.2.4

14.2.2.1 Read Capacity Command (25H)

TABLE 14.2.2-1. READ CAPACITY COMMAND

BIT BYTE(S)	7	6	5	4	3	2	1	0
0	0	0	1	0	0	1	0	1
1	LOGICAL UNIT NO.			0	0	0	0	0
2	LOGICAL BLOCK ADDRESS (MSB)							
3	LOGICAL BLOCK ADDRESS							
4	LOGICAL BLOCK ADDRESS							
5	LOGICAL BLOCK ADDRESS (LSB)							
6	0	0	0	0	0	0	0	0
7	0	0	0	0	0	0	0	0
8	0	0	0	0	0	0	0	PMI
9	0	0	0	0	0	0	FLAG	LINK
							0	0

The Read Capacity command (Table 14.2.2-1) provides a means for the initiator to request information regarding the capacity of the WREN V.

A Partial Medium Indicator (PMI) bit of zero indicates the information returned in the Read Capacity data shall be the Logical Block Address and Block Length (in bytes) of the last logical block of the logical unit. The Logical Block Address in the Command Descriptor Block shall be set to zero for this option.

A PMI bit of one indicates the information returned shall be the Logical Block Address and Block Length (in bytes) of the last Logical Block Address after which a substantial delay (defined as approximately 1 millisecond for the WREN V) in data transfer will be encountered. This Logical Block Address shall be greater than or equal to the Logical Block Address specified in the Command Descriptor Block. This reported Logical Block Address will be a cylinder boundary.

14.2.2.1 continued

The returned 8 bytes of Read Capacity Data are listed in Table 14.2.2-2.

TABLE 14.2.2-2. READ CAPACITY DATA

<u>BYTE</u>	<u>DESCRIPTION</u>
0	LOGICAL BLOCK ADDRESS (MSB)
1	LOGICAL BLOCK ADDRESS
2	LOGICAL BLOCK ADDRESS
3	LOGICAL BLOCK ADDRESS (LSB)
4	BLOCK LENGTH (MSB)
5	BLOCK LENGTH
6	BLOCK LENGTH
7	BLOCK LENGTH (LSB)

14.2.2.2 Read Extended Command (28H)

TABLE 14.2.2-3. READ EXTENDED COMMAND

BIT BYTE(S)	7	6	5	4	3	2	1	0
0	0	0	1	0	1	0	0	0
1	LOGICAL UNIT NO.						REL ADR	
	0	0	0	0	0	0	0	0
2	LOGICAL BLOCK ADDRESS (MSB)							
3	LOGICAL BLOCK ADDRESS							
4	LOGICAL BLOCK ADDRESS							
5	LOGICAL BLOCK ADDRESS (LSB)							
6	0	0	0	0	0	0	0	0
7	TRANSFER LENGTH (MSB)							
8	TRANSFER LENGTH (LSB)							
9	0	0	0	0	0	0	FLAG	LINK
							0	0

The Read Command requests that the target transfer data to the initiator.

14.2.2.2 continued

The Logical Block Address specifies the logical block at which the read operation shall begin.

The Transfer Length specifies the number of contiguous logical blocks of data that shall be transferred. A Transfer Length of zero indicates that no logical blocks shall be transferred (an Implied Seek is still performed). This condition shall not be considered an error. Any other value indicates the number of logical blocks that shall be transferred.

The data value most recently written in the addressed logical block shall be returned.

This command is implemented with the WREN V specific parameters listed in Table 14.2.2-3.

In the CDB the LUN must be zero and the Flag and Link bits must be zero. Relative Addressing is not implemented and the relative address (REL ADR) bit must be zero.

This command operates the same as the Read command (see Section 14.2.1.4) except that in the CDB for this command a four byte Logical Block Address and a two byte Transfer Length may be specified.

This command shall be terminated with a Reservation Conflict status if any reservation access conflict (see Section 14.2.1.8) exists, and no data shall be read.

14.2.2.2 continued

If any of the following conditions occur, this command shall return a Check Condition status and the Sense Key shall be set as indicated in enumeration of all conditions which may cause the Check Condition status.

<u>CONDITION</u>	<u>SENSE KEY</u>
Invalid Logical Block Address	Illegal Request (see note)
Target reset since last command from this initiator	Unit Attention
Unrecovered read error	Medium Error
Recoverable read error	Recovered Error
Overrun or other error that might be resolved by repeating the command	Aborted Command

NOTE: The extended sense information bytes shall be set to the Logical Block Address of the first invalid address.

14.2.2.3 Write Extended Command (2AH)

TABLE 14.2.2-4. WRITE EXTENDED COMMAND

BIT BYTE(S)	7	6	5	4	3	2	1	0
0	0	0	1	0	1	0	1	0
1	LOGICAL UNIT NO.						REL ADR	
	0	0	0	0	0	0	0	0
2	LOGICAL BLOCK ADDRESS (MSB)							
3	LOGICAL BLOCK ADDRESS							
4	LOGICAL BLOCK ADDRESS							
5	LOGICAL BLOCK ADDRESS (LSB)							
6	0	0	0	0	0	0	0	0
7	TRANSFER LENGTH (MSB)							
8	TRANSFER LENGTH (LSB)							
9	0	0	0	0	0	0	FLAG	LINK
							0	0

14.2.2.3 continued

The Write command requests that the WREN V write to the medium the data transferred by the initiator.

The Logical Block Address specifies the logical block at which the write operation shall begin.

The Transfer Length specifies the number of contiguous logical blocks of data that shall be transferred. A Transfer Length of zero indicates no logical blocks shall be transferred (an Implied Seek is still performed). This condition shall not be considered an error and no data shall be written. Any other value indicates the number of logical blocks that shall be transferred.

This command is implemented with the WREN V specific parameters listed in Table 14.2.2-4.

In the CDB, the LUN must be zero and the Flag and Link bits must be zero. The Relative Address (REL ADR) bit must be zero.

This command operates the same as the Write command (Section 14.2.1.5) except that in the CDB for this command a four byte Logical Block Address and a two byte Transfer Length may be specified.

This command shall be terminated with a Reservation Conflict status if any reservation access conflict (see Section 14.1.8) exists, and no data shall be written.

14.2.2.3 continued

If any of the following conditions occur, this command shall be terminated with a Check Condition status and the Sense Key shall be set as indicated in the following table. This table does not provide an exhaustive enumeration of all conditions which may cause the Check Condition status.

<u>CONDITION</u>	<u>SENSE KEY</u>
Invalid Logical Block Address	Illegal Request (see note)
Target reset since the last command from this initiator	Unit Attention
Overrun or other error that might be resolved by repeating the command	Aborted Command

NOTE: The extended sense information bytes shall be set to the Logical Block Address of the first invalid address. In this case, no data shall be written on the logical unit.

14.2.2.4 Seek Extended Command (2BH)

TABLE 14.2.2-5a. SEEK EXTENDED COMMAND

BIT BYTE(S)	7	6	5	4	3	2	1	0
0	0	0	1	0	1	0	1	1
1	LOGICAL UNIT NO.			0	0	0	0	0
2	LOGICAL BLOCK ADDRESS (MSB)							
3	LOGICAL BLOCK ADDRESS							
4	LOGICAL BLOCK ADDRESS							
5	LOGICAL BLOCK ADDRESS (LSB)							
6	0	0	0	0	0	0	0	0
7	0	0	0		0	0	0	0
8	0	0	0	0	0	0	0	0
9	0	0	0	0	0	0	FLAG	LINK
							0	0

14.2.2.4 continued

The Seek Extended command requests that the WREN V seek to the specified Logical Block Address.

This command is implemented with the WREN V specific parameters listed in Table 14.2.2-5a

In the CDB, the LUN must be zero and the Flag and Link bits must be zero. This command operates the same as the Seek command (Section 14.2.1.6) except that a four byte Logical Block Address is specified.

14.2.2.5 Write and Verify Command

TABLE 14.2.2-5b. WRITE AND VERIFY COMMAND

BIT BYTE(S)	7	6	5	4	3	2	1	0
0	0	0	1	0	1	0	1	1
1	LOGICAL UNIT NO.						BYT CHECK	0
2	LOGICAL BLOCK ADDRESS (MSB)							
3	LOGICAL BLOCK ADDRESS							
4	LOGICAL BLOCK ADDRESS							
5	LOGICAL BLOCK ADDRESS (LSB)							
6	0	0	0	0	0	0	0	0
7	TRANSFER LENGTH (MSB)							
8	TRANSFER LENGTH (LSB)							
9	0	0	0	0	0	0	FLAG 0	LINK 0

14.2.2.5 continued

The WRITE AND VERIFY command requests that the target write the data transferred from the initiator to the medium and then verify that the data is correctly written.

A byte check (BytChk) bit of zero causes the verification to be simply a medium verification (ECC). A BytChk bit of one causes a byte-by-byte compare of data written on the peripheral device and the data transferred from the initiator. If the compare is unsuccessful, the command shall be terminated with a CHECK CONDITION status and the sense key shall be set to MISCOMPARE.

The logical block address specifies the logical block at which the write operation shall begin.

The transfer length specifies the number of contiguous logical blocks of data that shall be transferred. A transfer length of zero indicates that no logical blocks shall be transferred. This condition shall not be considered as an error and no data shall be written. Any other value indicates the number of logical blocks that shall be transferred.

In the CDB, the LUN must be zero and the flag and Link bits must be zero.

For Systems which support disconnection, the WREN V will disconnect during the execution of this command.

14.2.2.6 Verify Command (2FH)

TABLE 14.2.2-6. VERIFY COMMAND

BIT	7	6	5	4	3	2	1	0	
BYTE(S)									
0	0	0	1	0	1	1	1	1	
1	LOGICAL UNIT NO.						BYT CHK		
	0	0	0	0	0	0		0	
2	LOGICAL BLOCK ADDRESS (MSB)								
3	LOGICAL BLOCK ADDRESS								
4	LOGICAL BLOCK ADDRESS								
5	LOGICAL BLOCK ADDRESS (LSB)								
6	0	0	0	0	0	0	0	0	
7	TRANSFER LENGTH (MSB)								
8	TRANSFER LENGTH (LSB)								
9	0	0	0	0	0	0	FLAG	LINK	
							0	0	

14.2.2.6 continued

The Verify command requests that the target verify the data written on the medium.

A Byte Check (BytChk) bit of zero causes the verification to be simply a medium verification (CRC, ECC, etc). A BytChk bit of one causes a byte by byte compare of data on the medium and the data transferred from the initiator. If the compare is unsuccessful, the command shall be terminated with a Check Condition status and the Sense Key shall be set to Miscompare.

The Logical Block Address specifies the logical block at which the verify operation shall begin.

The Verification Length specifies the number of contiguous logical blocks of data that shall be verified. A Verification Length of zero indicates that no logical blocks shall be verified (an Implied Seek is still performed). This condition shall not be considered an error. Any other value indicates the number of logical blocks that shall be verified.

This command is implemented with the WREN V specific parameters listed in Table 14.2.2-6.

The drive will disconnect while this command is being executed if the initiator supports disconnect/reconnect.

14.2.2.7 Search Data Commands (30H, 31H, or 32H)

Not implemented. If received, will be treated as an Illegal Request.

14.2.2.8 Set Limits Command (33H)

Not implemented. If received, will be treated as an Illegal Request.

14.2.2.9 Read Defect Data Command (37H)

TABLE 14.2.2-7a. READ DEFECT DATA COMMAND

BIT BYTE(S)	7	6	5	4	3	2	1	0
0	0	0	1	1	0	1	1	1
1	LOGICAL UNIT NO.			0	0	0	0	0
2	0	0	0	P	G	DEFECT LIST FORMAT		
				[1]		1	0	0[2]
						or 1	0	1
3	0	0	0	0	0	0	0	0
4	0	0	0	0	0	0	0	0
5	0	0	0	0	0	0	0	0
6	0	0	0	0	0	0	0	0
7	ALLOCATION LENGTH (MSB)							
8	ALLOCATION LENGTH (LSB)							
9	0	0	0	0	0	0	FLAG	LINK
							0	0

[1], [2], See following page for notes.

14.2.2.9 continued

Notes for Table 14.2.2-7a. Read Defect Data Command

[1] The WREN V interprets the P and G bits (bits 4 and 3 of byte 2 of the CDB) as follows:

<u>BIT P</u>	<u>BIT G</u>	
0	0	(1) Return Defect List header only
0	1	(2) Return the growth "G" list only.
1	0	(3) Return the manufacturers original ETF list only.
1	1	(4) Return all lists.

(1) If the P, G bits were 0,0, the Defect List length will reflect the length of the 1,1 list and no Defect Descriptor Bytes will be sent to the initiator.

(2) This list will reflect the grown or "G" list as defined in Section 14.2.1.2.

(3) This list reflects the manufacturers original ETF list. These defects may or may not have been reallocated, depending on the last Format command received (the last format may or may not have requested the P list flaws be reallocated during the format function).

(4) The returned list will contain all of the drive's defect lists (i.e. P, G, C & D) regardless of whether these lists have been reallocated by the drive.

[2] The Defect List format field indicates the defect data format preferred by the initiator. The meaning is the same as the Defect List Format field in the Format command (indicated in Table 14.2.1-3)

The Defect List format bits (bits 2, 1, 0 in the CDB) should be; 1 0 0, respectively, to signify a defect list in the Bytes from Index format, or, 1 0 1, respectively to signify a defect list in the Physical Sector format. If neither of these two, the WREN V will respond with the defect list in the drives default format (physical sector) and create the check condition status with Recovered Error Sense Key at the end of the Read Defect Data data transfer.

14.2.2.9 continued

The Read Defect Data command requests that the target transfers the medium defect data to the initiator.

This command is implemented with the WREN V specific parameters listed in Table 14.2.2-7a.

Allocation Length specifies the number of bytes the initiator has allocated for the returned defect data. An Allocation Length of zero indicates that no Read Defect Data shall be transferred. Any other value indicates the maximum number of bytes to be transferred. The WREN V shall terminate the Data In phase when the Allocation Length bytes have been transferred or when all available defect data has been transferred to the initiator, whichever is less.

In the CDB the LUN must be zero and the Flag and Link bits must be zero.

This command is intended to be used only with the Format Unit command (Section 14.2.1.2). The initiator should not interpret or act upon this list except to resend this list as defect data in a Format Unit command. It is not possible to relate actual physical locations to logical block addresses that are given in connection with other commands.

The Defect Data returned is listed in Table 14.2.2-7b.

The first 4 bytes returned are the Defect List Header. The P bit, G bit, and Defect List Format fields indicate the defect format actually returned by the WREN V. The definitions are the same as for byte 2 of the Read Defect Data Command Descriptor Block (Table 14.2.2-7a).

The Defect List Length specifies the total length in bytes of all the defect descriptors available from the WREN V. If the Allocation Length of the CDB is too small to transfer all of the defect descriptors, the Defect List Length is not adjusted to reflect the truncation. The Defect Descriptors do not have to be in ascending order.

14.2.2.9 continued

TABLE 14.2.2-7b. DEFECT LIST HEADER DESCRIPTION

BIT BYTE(S)	7	6	5	4	3	2	1	0
0	RESERVED							
	0	0	0	0	0	0	0	0
1	RESERVED			P	G	DEFECT LIST FORMAT		
	0	0	0	-----		1	0	0 [2]
				[1]	or 1		0	1
2	DEFECT LIST LENGTH (MSB)							
3	DEFECT LIST LENGTH (LSB) (VALUE IS 8 TIMES THE NUMBER OF DEFECTIVE SECTORS)							
4-n	DEFECT DESCRIPTOR BYTES [3]							
	DRIVE RETURNS DEFECTIVE SECTOR ADDRESS							

- [1] Either 00, 01, 10, or 11 as previously defined in note [1] of Table 14.2.2-7a.
- [2] 100 defines a list in the Bytes from Index format.
101 defines a list in the Physical Sector format.
- [3] If the P, G bits were 0,0 the Defect List length will reflect the length of the 1,1 list and no Defect Descriptor Bytes will be sent to the initiator. See Tables 14.2.1-6a and 14.2.1-6b for format of Defect Descriptor Bytes.

15.0 STATUS

A status byte shall be sent from the WREN V to the initiator during the Status phase at the termination of each command as specified in Table 15.0-1 and 15.0-2 unless the command is cleared by an Abort message, by a Bus Device Reset message, by a "hard" Reset condition, or by a catastrophic reset condition.

TABLE 15.0-1. STATUS BYTE

BIT	7	6	5	4	3	2	1	0
BYTE	0	0	0	0	0	0	0	0

The drive will return one of the completion status bytes codes listed in Table 15.0-2.

TABLE 15.0-2. COMMAND COMPLETION STATUS

<-----BITS----->								STATUS REPRESENTED
7	6	5	4	3	2	1	0	
0	0	0	0	0	0	0	0	Good
0	0	0	0	0	0	1	0	Check Condition
0	0	0	0	1	0	0	0	Busy
0	0	0	1	1	0	0	0	Reservation Conflict

A description of the status byte codes is given below:

Good - Indicates the WREN V has successfully completed execution of the command.

Check Condition - Any error, exception, or abnormal condition that causes sense data to be set, shall cause a Check Condition status. The Request Sense command should be issued in response to a Check Condition status, to determine the nature of the condition.

Busy - The WREN V is busy. This status shall be sent whenever a WREN V is unable to accept a command from an initiator. The normal initiator recovery action is to issue the command again at a later time.

15.0 continued

Reservation Conflict - This status shall be returned whenever a SCSI device attempts to access a logical unit that is reserved for that type of access to another SCSI device.

16.0 ERROR RECOVERY PHILOSOPHY

The error recovery procedures for the WREN V vary in accordance with parameter values and the states of "flags" stored in error recovery parameter storage locations in WREN V control memory. The WREN V control firmware error recovery routines reference these parameters for decision making when an error recovery procedure is performed. These error recovery parameters are changeable by commands from the initiator. The parameters are flagged as being changeable and this information is given to the initiator when requested by a Mode Sense command. The error recovery parameters can be changed by a Mode Select command from the initiator. Table 16.0-1 lists the error recovery parameters. More details, on how these functions operate, are given in Sections 14.2.1.7 and 14.2.1.10.

TABLE 16.0-1. ERROR RECOVERY PARAMETERS

CHANGEABILITY INDICATOR**

<u>PARAMETER NAME</u>		<u>VALUE</u>	<u>DESCRIPTION OF PARAMETER</u>
AWRE	1	1 or 0*	Automatic Write Reallocation Enable
ARRE	1	1 or 0*	Automatic Read Reallocation Enable
TB	1	1 or 0*	Transfer (failed data) Block
RC	1	1 or 0*	Read Continuous (no recovery actions)
EEC	1	1 or 0*	Enable ECC correction to occur early
PER	1	1 or 0*	Post Error (report to initiator)
DTE	1	1 or 0*	Disable data Transfer on Recovered Error
DCR	1	1 or 0*	Disable ECC application
Retry cnt	1	0 - 27	Maximum times for read retry algorithm
Correction Span	0	11	Largest error span for ECC use (bits)

*Default value is 0 which means disable.

**1 means is changeable, 0 means not changeable.

16.0 continued

In general, when a read error occurs, the WREN V will attempt to recover using retries, application of ECC and/or early application of ECC (if these are enabled). If the error still exists, the WREN V will report Check Condition in the status returned to the initiator. The initiator will likely command Request Sense and the WREN V will reply with a Data In phase with 18 bytes of Extended Sense Data which will contain information about the error. Sense Key codes used and their meanings are listed in Table 14.1.1-5. Error codes used and the errors they report are listed in Table 14.1.1-6. If the error is recovered, it will be reported only if the PER bit is set (Table 16.0-1). Error recovery procedures for several of the error conditions are defined in Sections 16.1 through 16.5.

16.1 SEEK ERRORS (09 or 15 HEX ERROR CODE)

If a seek error occurs, up to three retries will be attempted by positioning the heads to track zero and reissuing the seek. If all retries fail error code 09 or 15 will be reported in the Extended Sense Data.

16.2 DATA FIELD WRITE FAULT (03 HEX ERROR CODE)

If a write fault is detected while writing the data field the operation will be immediately suspended. If the internal write fault can be cleared, the drive will automatically perform a rewrite of the sector (up to 3 attempts will be made to clear the write fault and rewrite the sector).

If the write fault condition cannot be cleared the "Write Fault" error (03 Hex) will be reported in extended Sense Data.

16.3 SYNC BYTE ERROR (12 Hex Error Code)

If the sync byte cannot be recovered during a read, up to 27 retries will be attempted using the offset and data strobe combinations shown in Figure 16.3-1.

Nominal Data Strobe	No Servo Offset	Retry 3 times
	Servo Offset Plus	Retry 3 times
	Servo Offset Minus	Retry 3 times
Early Data Strobe	No Servo Offset	Retry 3 times
	Servo Offset Plus	Retry 3 times
	Servo Offset Minus	Retry 3 times
Late Data Strobe	No Servo Offset	Retry 3 times
	Servo Offset Plus	Retry 3 times
	Servo Offset Minus	Retry 3 times

FIGURE 16.3-1. POSSIBLE DATA STROBE AND SERVO OFFSET COMBINATIONS USED BY THE SCSI WREN DURING READ RETRIES

16.4 DATA FIELD ECC ERROR (11 Hex or 18 Hex Error Code)

If EEC bit is one (Table 14.2.1-23), ECC correction is applied as soon as possible. If EEC bit is zero data field ECC error correction is not applied until all retry attempts (per Figure 16.3-1) are exhausted and if specified by DCR bit and Retry Count (Table 14.2.1-23). If the ECC error persists and is within the correction span being used (11 bits) the data is corrected and sent to the initiator if that capability is enabled by DTE bit (Table 14.2.1-23). Data correction by ECC will not occur unless two ECC syndrome matches occur. For unrecoverable ECC errors an error code of 11 Hex is reported.

16.5 ALTERNATE SECTOR PROCESSING

Any media defect detected during formatting or listed internally in the factory recorded defect table will already have been assigned an alternate sector in an area not directly accessible by the initiator. If conditions are appropriate, the initiator may want to call for a complete reformatting of the WREN V. The options available when that is done are discussed in Section 14.2.1.2.

If Automatic Read Reallocation (ARRE) is disabled, the initiator should request that media errors (that occur after formatting) be reassigned using a Reassign Blocks command.

If Automatic Read Reallocation (ARRE) is enabled, read errors that require more than 3 retries to recover or read errors that require ECC correction to recover will be automatically reallocated by the drive. The initiator should not use the Reassign Blocks command to reallocate these flaws. The initiator should still use the Reassign Blocks command to reallocate unrecoverable sectors.

If Automatic Write Reallocate (AWRE) is disabled, the drive will report a No Record Found status if a header cannot be recovered. The initiator should request that bad sector(s) be reallocated using the Reassign Blocks command and then rewrite the record.

If Automatic Write Reallocation (AWRE) is enabled, the drive will automatically reallocate the sector and rewrite the data field if a header cannot be recovered. The initiator should not use the Reassign Blocks command or rewrite the sectors if AWRE is a 1 and it receives a Record Not Found status.

17.0 OPTIONS

All options are incorporated or packaged at the manufacturing facility.

17.1 FRONT PANEL

The normal front panel available is black plastic. Other panel colors may be special ordered. Each panel has a single rectangular LED indicator lens which, when glowing indicates the drive is selected. LED lens colors available are red, amber or green.

17.2 SINGLE UNIT SHIPPING PACK

The 94181 WREN V is normally shipped in bulk packaging to provide maximum protection against transit damage. Units shipped individually require additional protection as provided by the single unit shipping pack. Users planning single unit distribution should specify this option.

17.3 DRIVE TERMINATION

This option may be incorporated during manufacture at the request of the customer. Termination consists of three 220/330 ohm resistor modules which are installed on the Main PWA via sockets (see Figure 10.3-3). The user may install or remove these as desired.

18.0 ACCESSORIES

All accessories are designed for implementation by the customer.

18.1 FRONT PANEL KIT

Same as 17.1 but includes all mounting hardware to support field installation.

18.2 OEM MANUAL

This manual provides basic information on the care and handling of Winchester Disk Peripherals in general. Specific instructions for installing the WREN V are included to assist individuals not familiar with the product. It also includes basic information describing repair procedures for items external to the Head/Disk/Actuator Assembly (HDA).

APPENDIX A
SCSI PROTOCOL ERROR HANDLING FLOW CHARTS

GLOSSARY OF FLOWCHART ABBREVIATIONS

ATTN	Attention signal on SCSI bus
BDR	Bus Device Reset message
BF	Bus Free phase
CMD	Command
DISCON	Disconnect message
ERR CD	Error Code in Request Sense byte 12
HDWE ERR	Hardware Error Sense Key
ID	Identify message
IDE	Initiator Detected Error message
LUN	Logical Unit Number
MPE	Message Parity Error message
MR	Message Reject message
MSG	Message
NOOP	No Operation message
PAR ERR	Parity Error was detected during Message Out phase
RES	Any Reserved or unimplemented message code (extended or nonextended)
RP	Reset Pointers message
SDP	Save Data Pointer message
STR	Synchronous Data Transfer Request message
U.A.	Unit Attention condition

3127-1

0221D

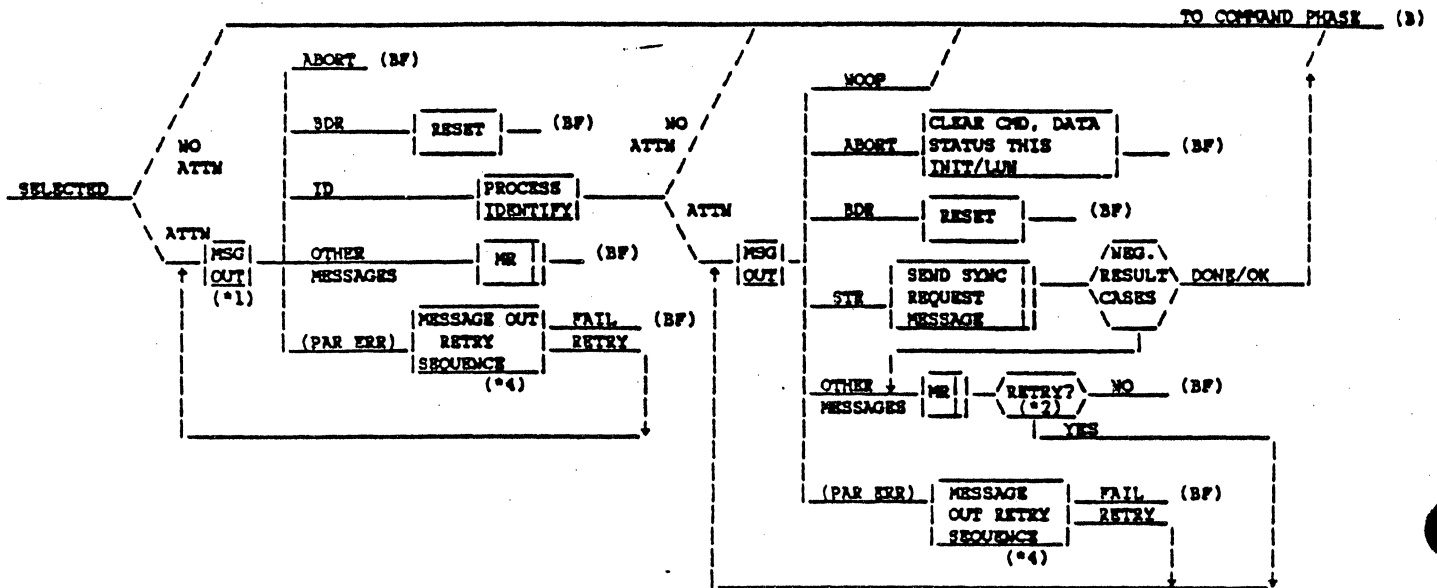

FLOWCHART 1. SELECTION MESSAGES

Notes:

1. MSG OUT may accept the next complete message (1 or 5 bytes) or may accept and buffer all message bytes available while ATN is asserted.
2. Retry is optional in these cases. If messages are buffered; discard.
3. The MSG OUT retry sequence will insure that any buffered messages are discarded and that ATN is false.

4.

--	--

 Indicates a transmission to the Host.

(2445P)

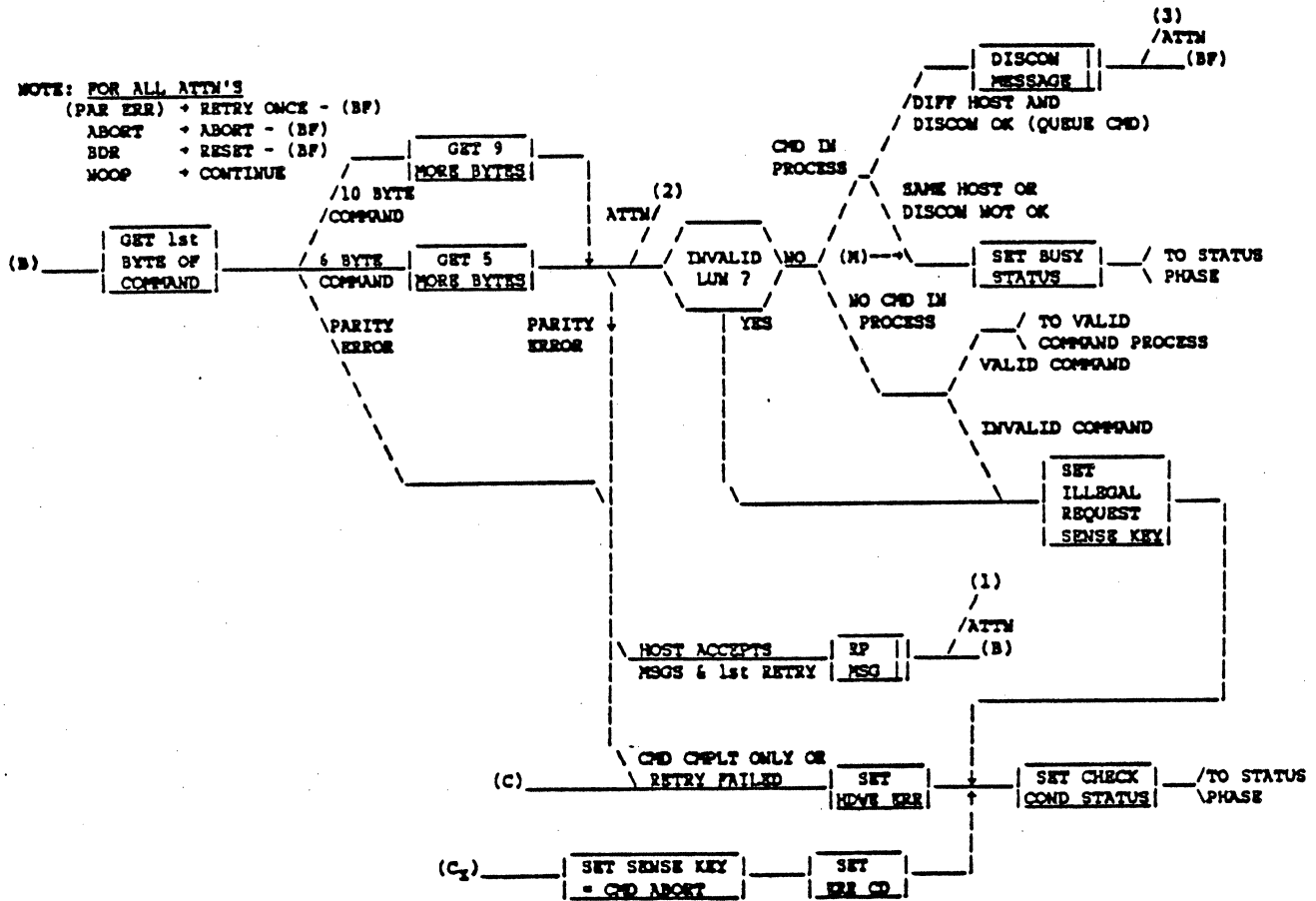

(1)
 IDE → MR - (C_X)
 STR → MR - (C_X)
 MR → (C)
 MPE → RETRY ONCE - (BF)
 ID → MR - (C_X)
 RES → MR - (C_X)

(2)
 IDE → RP - (B)
 STR → MR - (C_X)
 MR → MR - (C_X)
 MPE → MR - (C_X)
 ID → MR - (C_X)
 RES → MR - (C_X)

(3)
 IDE → MR - (C_X)
 STR → MR - (C_X)
 MR → MR
 MPE → RETRY ONCE - (BF)
 ID → MR - (C_X)
 RES → MR - (C_X)

FLOWCHART 2. COMMAND PHASE

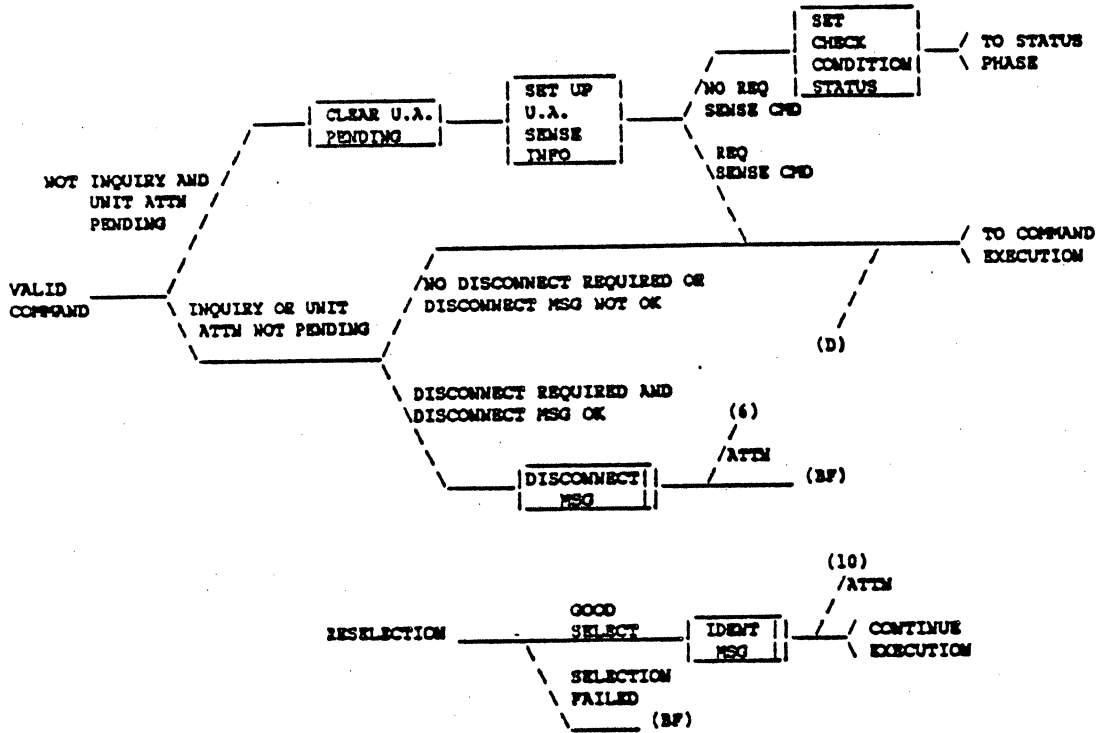

(6)
 IDE -> MR - (C_X)
 STR -> MR - (C_X)
 MR -> (D) (DO NOT DISCONNECT)
 MPE -> RETRY ONCE - (BF)
 ID -> MR - (C_X)
 RES -> MR - (C_X)

(10)
 IDE -> MR - (C_X)
 STR -> MR - (C_X)
 MR -> MR - (BF)
 MPE -> RETRY ONCE - (BF)
 ID -> MR - (C_X)
 RES -> MR - (C_X)

FLOWCHART 3. VALID COMMAND PROCESS

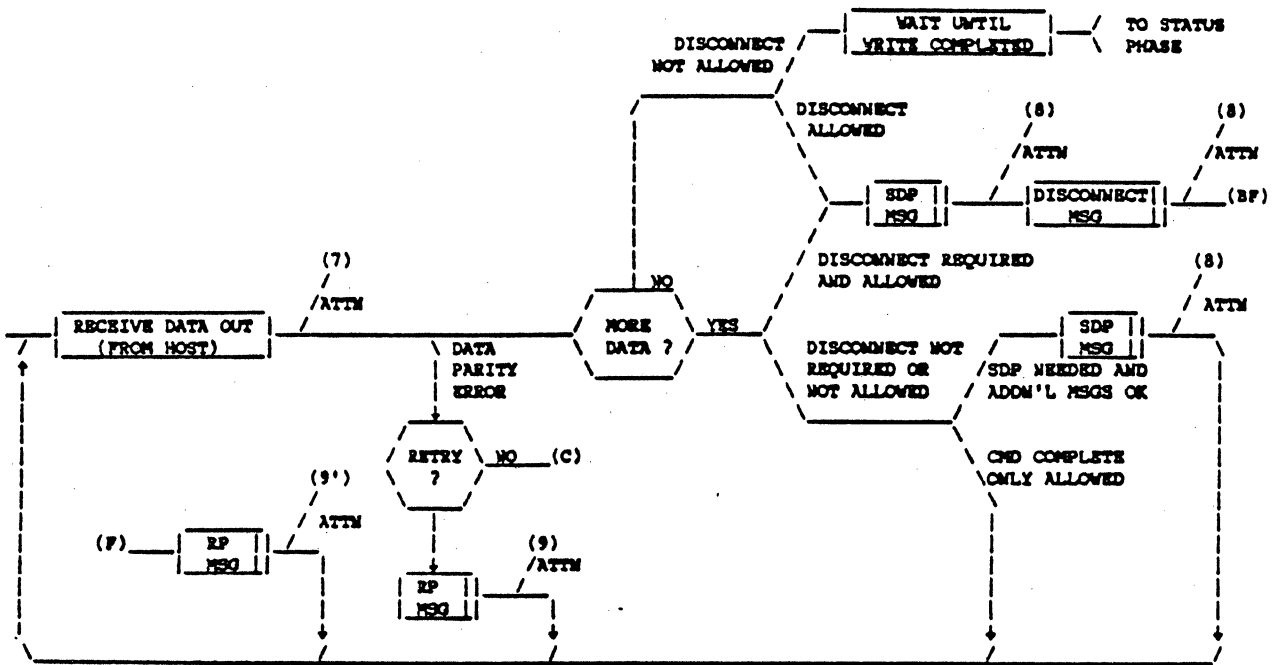

(7)
 IDE -> (F)
 STR -> MR - (Cx)
 MR -> MR - (Cx)
 MPE -> MR - (Cx)
 ID -> MR - (Cx)
 RES -> MR - (Cx)

(9 & 9')
 IDE -> MR - (Cx)
 STR -> MR - (Cx)
 MR -> (Cx) or (Cx')
 MPE -> RETRY ONCE - (BF)
 ID -> MR - (Cx)
 RES -> MR - (Cx)

(8)
 IDE -> MR - (Cx)
 STR -> MR - (Cx)
 MR -> CONTINUE
 MPE -> RETRY ONCE - (BF)
 ID -> MR - (Cx)
 RES -> MR - (Cx)

FLOWCHART 4. DATA OUT PHASE

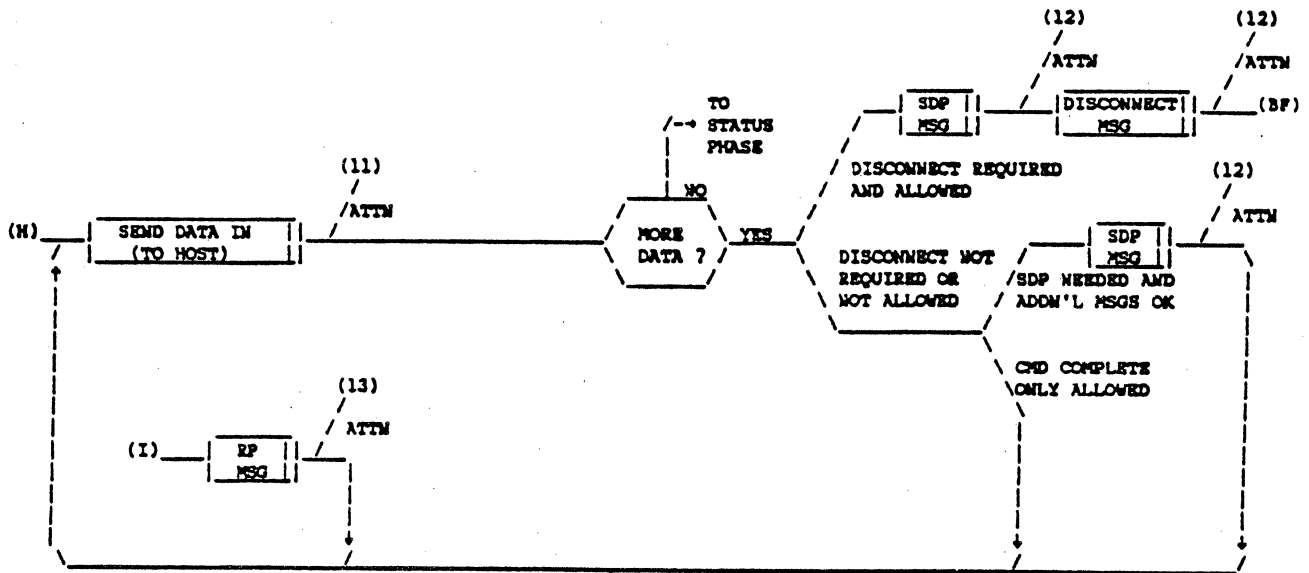

(11)
 IDE -> (I)
 STR -> MR - (Cx)
 MR -> MR - (Cx)
 MPE -> MR - (Cx)
 ID -> MR - (Cx)
 RES -> MR - (Cx)

(13)
 IDE -> MR - (Cx)
 STR -> MR - (Cx)
 MR -> (Cx)
 MPE -> RETRY ONCE - (BF)
 ID -> MR - (Cx)
 RES -> MR - (Cx)

(12)
 IDE -> MR - (Cx)
 STR -> MR - (Cx)
 MR -> (H)
 MPE -> RETRY ONCE - (BF)
 ID -> MR - (Cx)
 RES -> MR - (Cx)

FLOWCHART 5. DATA IN PHASE

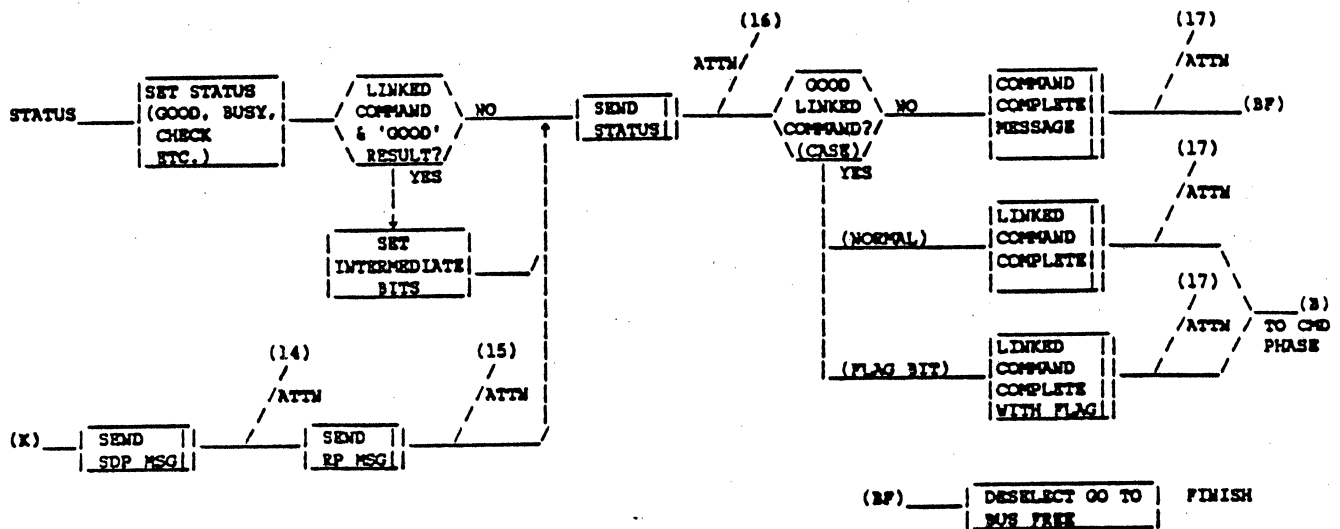

(14)
 IDE->MR-CONTINUE
 STR->MR-CONTINUE
 MR ->CONTINUE
 MPE->RETRY ONCE-(BF)
 ID ->MR-CONTINUE
 RES->MR-CONTINUE

(15)
 IDE->MR-CONTINUE
 STR->MR-CONTINUE
 MR ->CONTINUE
 MPE->RETRY ONCE-(BF)
 ID ->MR-CONTINUE
 RES->MR-CONTINUE

(16)
 IDE->(K) IF FIRST TRY
 STR->MR-CONTINUE
 MR ->CONTINUE
 MPE->MR-CONTINUE
 ID ->MR-CONTINUE
 RES->MR-CONTINUE

(17)
 IDE->MR-(BF)
 STR->MR-(BF)
 MR ->(BF)
 MPE->RETRY ONCE-(BF)
 ID ->MR-(BF)
 RES->MR-(BF)

FLOWCHART 6. STATUS PHASE