

49769800



---

# **92192 TAPE CARTRIDGE SUBSYSTEM**

**BY5A5**

**DESCRIPTION  
INSTALLATION AND CHECKOUT  
I/O REQUIREMENTS  
OPERATION  
MAINTENANCE**

---

**USERS GUIDE**

## PREFACE

The purpose of this Users Guide is to provide information relative to the customers' requirements to properly operate the 92192 Subsystem.

Information contained in this Users Guide includes a general description, power and environmental requirements, operation, operator maintenance, installation, input/output requirements, and sense data.

Equipment Identification - ID plate located on the right side of casting.

BY5A5A - Basic Transport (92192)

BY5A5B - Transport With Bezel (92192)

### WARNING

This equipment generates, uses, and can radiate radio frequency energy, and if not installed and used in accordance with the instructions contained herein, may cause interference to radio communications. It has been tested and found to comply with the limits for a Class A peripheral computing device pursuant to Subpart J of Part 15 of the FCC Rules, which are designed to provide reasonable protection against such interference when operated in a commercial environment. Operation of this equipment in a residential area is likely to cause interference, in which case, the user, at his own expense, will be required to take whatever measures may be required to correct the interference.

The transport is listed by the safety agencies (UL and CSA) as a component. A suitable enclosure is required which meets the Product Safety standards imposed by agencies such as UL and CSA.

Electromagnetic Interference (EMI) emissions of a total system are affected by the physical placement of components (subassemblies) within their final enclosure, the type of enclosure, the enclosure openings, the type of cables, the cable arrangement, the grounding system, and the effects of other equipment in the total system.

It is the user's responsibility to verify that his system complies with the applicable FCC emission limits.

REV. A, 11-21-83

PUB. NO. 49769800

## TABLE OF CONTENTS

PARAGRAPH TITLE	PAGE
<u>DESCRIPTION</u>	1
<u>INSTALLATION AND CHECKOUT</u>	3
UNPACKING	3
PACKAGE CONTENTS	3
VISUAL INSPECTION	4
POWER REQUIREMENTS	5
SAFETY REQUIREMENTS	6
GROUNDING	6
<u>I/O REQUIREMENTS</u>	6
MOUNTING	7
ELECTRO-MAGNETIC COMPATIBILITY	7
<u>OPERATION</u>	7
DEVICE STATUS	7
TAPE CARTRIDGE HANDLING	7
OPERATORS INDICATORS (OPTIONAL)	8
HEALTH CHECK	9
<u>MAINTENANCE</u>	10
CLEANING	10
MAINTENANCE REPAIR CENTERS	11
PACKAGING	11

## DESCRIPTION

### GENERAL

The Quarter Inch Tape Cartridge Subsystem (92192), referred to as the device, is a microprocessor-based electronic and mechanical assembly intended for use in disk backup applications, using sequential recording techniques in a streaming mode only. The device consists of integrated formatter/control electronics and cartridge drive transport.

Formatter/Control electronics provide data encoding, decoding, error detection, host system interfacing, and control of tape cartridge drive. The tape drive system is an electro-mechanical assembly consisting of cartridge load/unload and positioning mechanism, drive motor/tachometer assembly, positionable single track magnetic head, head positioning mechanism, beginning of tape (BOT)/end of tape (EOT) sense electronics, and optional front mounting bezel with operator indicators.

For optimum performance, the tape cartridge recommended for use in the device is an industry-standard cartridge containing a 600-foot length, 1/4-inch wide magnetic tape, drive wheel/tensioning band arrangement, BOT/EOT positioning holes, and file protect port for securing recorded data. This device provides read interchangeability with 450-foot cartridges. Continued use of 300-foot tape cartridges (3M-DC300A) may result in degradation of Read/Write operation.

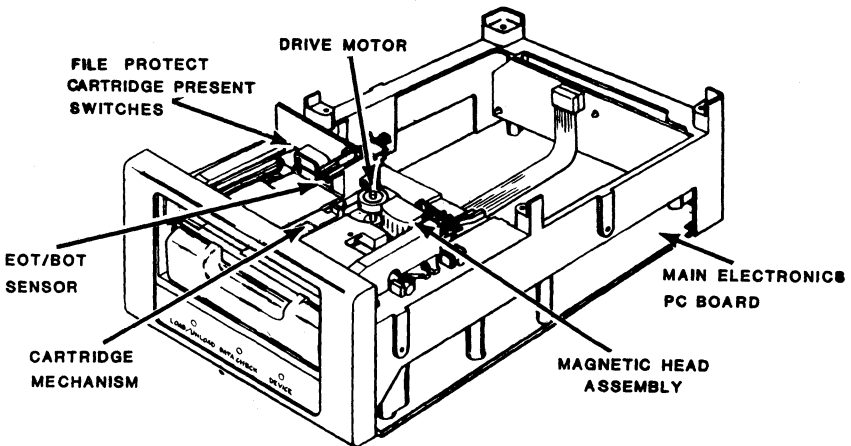

Figure 1. 92192 QUARTER INCH TAPE CARTRIDGE SUBSYSTEM

Table 1. PERFORMANCE CHARACTERISTICS

Tape Speed	55 inches per second
Recording Mode	Streaming Serpentine Recording
Tape Cartridge	Similar to cartridge per ANSI STD X3.55-1982. Tape is 1/4 inch wide and 600 feet long.
Cartridge Capacity (with 4Kbyte blocks)	64 megabytes
Recording Density	8000 bits per inch
Maximum Time To Dump 40 Megabytes	20 minutes
Weight	8 pounds
Dimensions	
Height	4.6 inches
Width	8.5 inches
Depth	14.0 inches maximum (bezel extends 0.86 inches to the front)
Power Voltage	+12V, -12V, +5V
Mounting	Standard 8-inch disk configuration, horizontal or vertical
Signal Levels	TTL Compatible
Temperature	
Operating	50°F (10°C) to 104°F (40°C)
Storage	14°F (-10°C) to 122°F (50°C)
Transit	-40°F (-40°C) to 140°F (60°C)
Humidity	
Operating	20% to 80% (No Condensation) with a Dew Point Temperature of 25°F (-4°C) to 79°F (26°C)
Storage	10% to 90% (No Condensation)
Transit	5% to 95% (No Condensation)
Altitude	-983 feet (-300 meters) to 9850 feet (3000 meters)

CAUTION

Though device shall be fully operational through the above limits, degraded read/write performance will be expected based on known performance characteristics of tape media, if unit is operated outside the following limits:

Temperature: 60°F (-16°C) to 90°F (32°C)  
Humidity: 35% to 60% R.H.  
Wet Bulb Temperature: 79°F (26°C)

## INSTALLATION AND CHECKOUT

### UNPACKING

Unpack the device as follows:

1. Remove the two-part styrofoam shell from cardboard shipping container.
2. Lift top half of styrofoam shell from device.
3. Lift unit in static control bag from bottom half of styrofoam shell and remove unit from static control bag.
4. Remove foam block from cartridge ejector cavity at release handle. Depress ejector handle to release the shipping block assembly.
5. Retain all packaging material for reuse.

During unpacking, inspect the device for possible shipping damage. All claims for this type of damage should be filed promptly with the carrier involved. If a file is claimed for damages, save the original packing materials.

### PACKAGE CONTENTS

The packaged unit may or may not have parts and hardware requiring assembly, depending on the model of the device. Identify the device by the BY5A5 with suffix letter A or B located on the Equipment Identification plate on the left side of the device. Check package contents versus BY number as follows:

BY5A5A - Device Only

BY5A5B - Device with Bezel Assembly Installed  
Indicator Panel Strips  
(Horizontal & Vertical)

## VISUAL INSPECTION

Visually inspect the following areas of the device and bezel assembly prior to mounting:

- o Indicator Panel

Check for cracks, scratches or abrasions.

- o Connectors

Inspect for proper mating of plugs to connectors.

- o PC Board

Check for proper seating of all pluggable integrated circuits.



POWER REQUIREMENTS

Input power for operation of the DC motors and PC board assembly must be supplied remotely via the power connector J13 located at the rear of the device. The device does not have an internal power supply. Voltage/Current requirements are as follows:

<u>OPERATING CONDITION</u>	<u>VOLTAGE</u>		
	+12V $\pm$ 10%*	-12V $\pm$ 10%*	+5V $\pm$ 5%**
92192 Forward Motion	2.0A	0.6A	3A
92192 Reverse Motion	1.0A	1.7A	3A

- \* Maximum average power during tape motion. 4.0A surge for 100 msec during start/stop. Ripple not to exceed 250 mv.
- \*\* Maximum continuously, ripple not to exceed 100 mv.

NOTE

Voltage supplied to the device must be provided by a "SAFETY EXTRA LOW VOLTAGE" source, as defined by IEC 380.

The power connector J13 mates with an AMP Connector Housing P/N 1-480702-0 and Contact Socket P/N 350551-1 or equivalent. Pin assignments for the connector are as follows:

<u>ASSIGNMENT</u>	<u>PIN</u>
-12V	1
+12V	2
GND	3
+5V	4

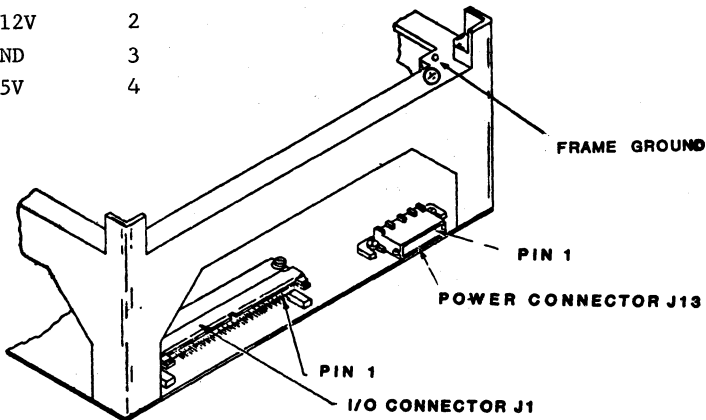

Figure 2. POWER AND I/O CONNECTOR LOCATIONS

## SAFETY REQUIREMENTS

In order to maintain Safety Organization Certification, it is required to comply with the following:

- o Each supply voltage should be fused at no more than 5.0 amps.
- o Grounding continuity must be maintained between the device frame and host equipment.

## GROUNDING

A #8-32 tapped hole is provided at the rear of the device for grounding of the frame.

## I/O REQUIREMENTS

The device interface input and output signals are all TTL Compatible. Device inputs are terminated with a 220-330 ohm resistor network, while the outputs are driven with an open-collector output stage. I/O signal levels are low true between Host and Device. I/O connector J1 mates with Berg Connector P/N 65847-033 or equivalent.

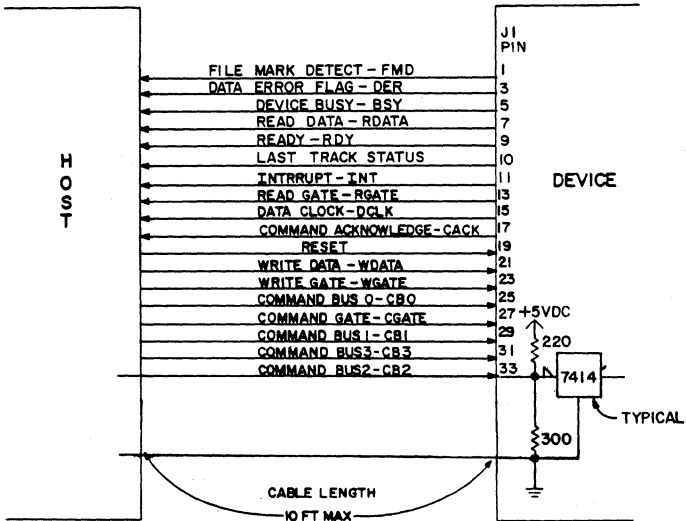

### NOTE:

ALL EVEN PINS, EXCEPT 10  
ARE LOGIC GROUND.

Figure 3. I/O LINES AND PIN ASSIGNMENTS

## MOUNTING

The device can be installed in a user mounting unit either in a horizontal or vertical position. The only consideration for cabinet or other enclosed mounting unit is defined by the environmental requirements listed in Table 1.

Mounting holes are provided on the side and bottom of the device to accommodate either horizontal or vertical mounting. Mounting with drawer-type slides is suggested to provide easy access for operator maintenance.

## ELECTRO-MAGNETIC COMPATIBILITY (EMC)

All cables external to the cabinet housing the device should be properly shielded using 3M P/N 3517/34, or equivalent.

## OPERATION

### DEVICE STATUS

There is no power "ON" or "OFF" switch on the device. As long as power is present at the connector, the device is in a Ready condition. If the optional front indicator panel is used, the operational status of the device is indicated by the operator indicators. Refer to OPERATOR INDICATORS (OPTIONAL) paragraph. If the front indicator panel is not used, device status is available to the host controller via the sense data lines.

## TAPE CARTRIDGE HANDLING

### CAUTIONS

Under no circumstances should operator allow finger contact with either magnetic tape or cartridge drive capstan. Any residue from contact with device wheel may affect friction requirements between drive wheel and cartridge capstan.

If a cartridge is dropped or otherwise mishandled, it is suggested that operator issue a Cartridge Health Check command to verify that cartridge is operational prior to writing.

#### o Storage

The cartridge can withstand storage temperature ranges from 41°F (5°C) to 113°F (45°C). The cartridge should be conditioned, by exposure to the operating environment, a time equal to or greater than time away from operating environment (up to 8 hours maximum).

#### o Cartridge Loading

Insert a cartridge into the device with the clear plastic surface toward the top of the device (device mounted horizontally). When the cartridge is partially positioned in the slot, position thumb at the center of the cartridge and push until the release bar latches the cartridge in place.

#### o Cartridge Unloading

Press the release bar away from the cartridge until it latches in the open position. The cartridge will be automatically extended about one inch so that it can be removed from the device.

#### o File Protect

The file protect port is a clear cylinder integrated into the front portion of the tape cartridge. Where the cylinder is positioned so that the arrow points to the word SAFE, the file is protected and write operations are not functional. When the arrow points away from the word SAFE, write operations are permitted. The cylinder top is slotted to allow selection of the file protect function.

## OPERATOR INDICATORS (OPTIONAL)

The front bezel and operator indicators are provided as an option to the standard device. Indicator functions are as follows:

- o Load/Unload (GREEN)  
When illuminated, indicates a cartridge can be inserted or removed without interrupting the device function in progress.
- o Data Check (YELLOW)  
When illuminated, indicates that excessive read or write errors have been detected. It is recommended that the magnetic head be cleaned to maintain read/write performance. Successive data checks may indicate a defective cartridge.
- o Device (RED)  
When illuminated, indicates that the Health Check Routine or functional microcode has detected a fault within the device hardware, and the device is not operational.

Data Check and Device indicators remain active until the Host issues a Sense command.

## HEALTH CHECK

Basic operational tests executed after power-on, on the following areas of the device to ensure the device meets minimum operating conditions, are as follows:

- o Microprocessor RAM Memory
- o Drive Motion - Speed, Acceleration and Deceleration
- o Head Positioner Motion
- o BOT/EOT Lamp Current Presence
- o Write-to-Read Loopback Through Encoding and Decoding Logic (Magnetic Head, Read Amplifier, and Write Drivers excluded)
- o Normal Device Status

### NOTE

A full Health Check cannot be evoked if the cartridge is loaded. If the cartridge is loaded during a power-on, an abbreviated Health Check is performed, with no capstan motion or write-to-read loopback.

## MAINTENANCE

### CLEANING

The only areas requiring operator cleaning are the magnetic head and drive wheel.

- o Magnetic Head/Cleaner Assembly

Clean head surface using cotton swab moistened with tape transport cleaner P/N 95961030. Move cotton swab in a vertical direction (perpendicular to tape motion) across the head recording surface and cleaner blades. Perform this cleaning procedure twice a week or whenever required by the operator indicator (DATA CHECK).

- o Drive Roller

The drive roller should not require cleaning if the Cautions noted for Tape Cartridge Handling are adhered to . If the drive roller should become contaminated, causing Tape Position Faults (Sense Byte 8, Bit 4), Noise (Sense Byte 3, Bit 3), and/or excessive data errors, it should be cleaned using the following procedure and retried before returning the unit for repair.

Clean the roller using a cloth moistened with tape transport cleaner P/N 95961030. Use a cloth-covered finger of one hand to move drive roller while cleaning with dampened cloth on other hand.

## MAINTENANCE REPAIR CENTERS

Contact the nearest Control Data Sales Office for repair center locations.

## PACKAGING

If it is necessary to reship the device, use the original packaging material and repackage the device as follows:

### NOTE

If it is necessary to order new packaging for the device, contact:

Computer Peripherals, Inc.  
Business Management Office  
2621 Van Buren Avenue  
Norristown, PA. 19403

When ordering, specify the exact equipment number and series code of the device, as shown on the Equipment Identification label.

1. Insert the shipping block assembly as you would a cassette, and position it with the smooth side up and the felt pad protector to the front away from the operator. Position a foam block into the cartridge ejector cavity.
2. Place unit into static control bag and place in bottom half of styrofoam shell.
3. Place top half of styrofoam shell onto device and place in cardboard shipping container.
4. Secure cardboard container with reinforced tape.

Table 2. SENSE DATA

SENSE BYTE 0		SENSE BYTE 1		SENSE BYTE 2	
BIT	DEFINITION	BIT	DEFINITION	BIT	DEFINITION
0	Motion Fault	0	Cartridge Present	0	Trk Counter Bit 0(LSB)
1	Defective Cartridge	1	Write Protect	1	Trk Counter Bit 1
2	Health Check Fault	2	Load Point	2	Trk Counter Bit 2
3	No Lamp Current	3	Early Warning	3	Trk Counter Bit 3(MSB)
4	Head Position Fault	4	Write Current Present	4	Model Code Bit 0(LSB)
5	Data HER	5	File Mark Detected	5	
6	Preliminary EOT	6	Retry In Process	6	
7	Illegal Command	7	Stripe Found	7	Model Code Bit 3(MSB)
SENSE BYTE 3		SENSE BYTE 4		SENSE BYTE 5	
0	Crease Detected	0	Max. Read Error Count	0	Read Err Cntr Bit 0(LSB)
1	RFU	1	Max. Write Error Count	1	1
2	MK1 Not Found	2	Max. Read Retry	2	2
3	Noise (On Erase) *	3	Max. Write Retry	3	3
4	No Data (16' Timeout) *	4	Retry Cntr Bit 0(LSB)	4	4
5	No RGATE	5	Retry Cntr Bit 1	5	5
6	No Read-After-Write	6	Retry Cntr Bit 2(MSB)	6	6
7	Long Record *	7	Retry Counter Bit 3	7	Read Err Cntr Bit 7(MSB)
SENSE BYTE 6		SENSE BYTE 7		SENSE BYTE 8	
0	Write Err Cntr Bit 0(LSB)	0	Last Command Bit 0(LSB)	0	No Tachs
1	1	1	Last Command Bit 1	1	Under-speed
2	2	2	Last Command Bit 2	2	Over-speed
3	3	3	Last Command Bit 3(MSB)	3	Time-out
4	4	4	Prev. Command Bit 0(LSB)	4	Tape Position Fault
5	5	5	Prev. Command Bit 1	5	Stop Fault
6	6	6	Prev. Command Bit 2	6	Tape Break
7	Write Err Cntr Bit 7(MSB)	7	Prev. Command Bit 3(MSB)	7	Unexpected EOT/BOT

\* These data errors will cause DATA HER and INTERRUPT. Also, LONG RECORD ERROR can be set on read or write.



Table 2. SENSE DATA (Cont'd)

SENSE BYTE 9		SENSE BYTE 10		SENSE BYTE 11	
BIT	DEFINITION	BIT	DEFINITION	BIT	DEFINITION
0	CS Error	0	Error Add.(LSB) Bit 0	0	Error Add.(LSB) Bit 0
1	RFU	1		1	
2		2		2	
3		3		3	
4		4		4	
5		5		5	
6		6		6	
7	RFU	7	Error Add.(MSB) Bit 7	7	Error Add.(MSB) Bit 7

SENSE BYTE 12	
0	Upper/Lower Tape Sense
1	EW Write Error
2	RFU
3	RFU
4	End State-EOT On Last Trk
5	EOT Interrupt
6	BOT Interrupt
7	LP/EW Interrupt

SENSE BYTE 13	
0	Cntrlware Rev Level Bit 0
1	
2	
3	
4	
5	
6	
7	Cntrlware Rev Level Bit 7

SENSE BYTE 14	
0	WFM Flag
1	Tach Verification Flag
2	ERS Flag
3	SFM Flag
4	RDF Flag
5	BKSP Flag
6	REPOS In Progress Flag
7	WR Stripe In Prog. Flag

SENSE BYTE 15	
0	Cartridge Initial Flag
1	Write Enable Flag
2	Seek Stripe In Prog. Flag
3	Health Chk In Prog. Flag
4	600' Flag
5	RFU
6	Cartridge Hlth Chk Comp.
7	RFU