

ROYTRON 

TAPE PUNCHES AND  
READERS

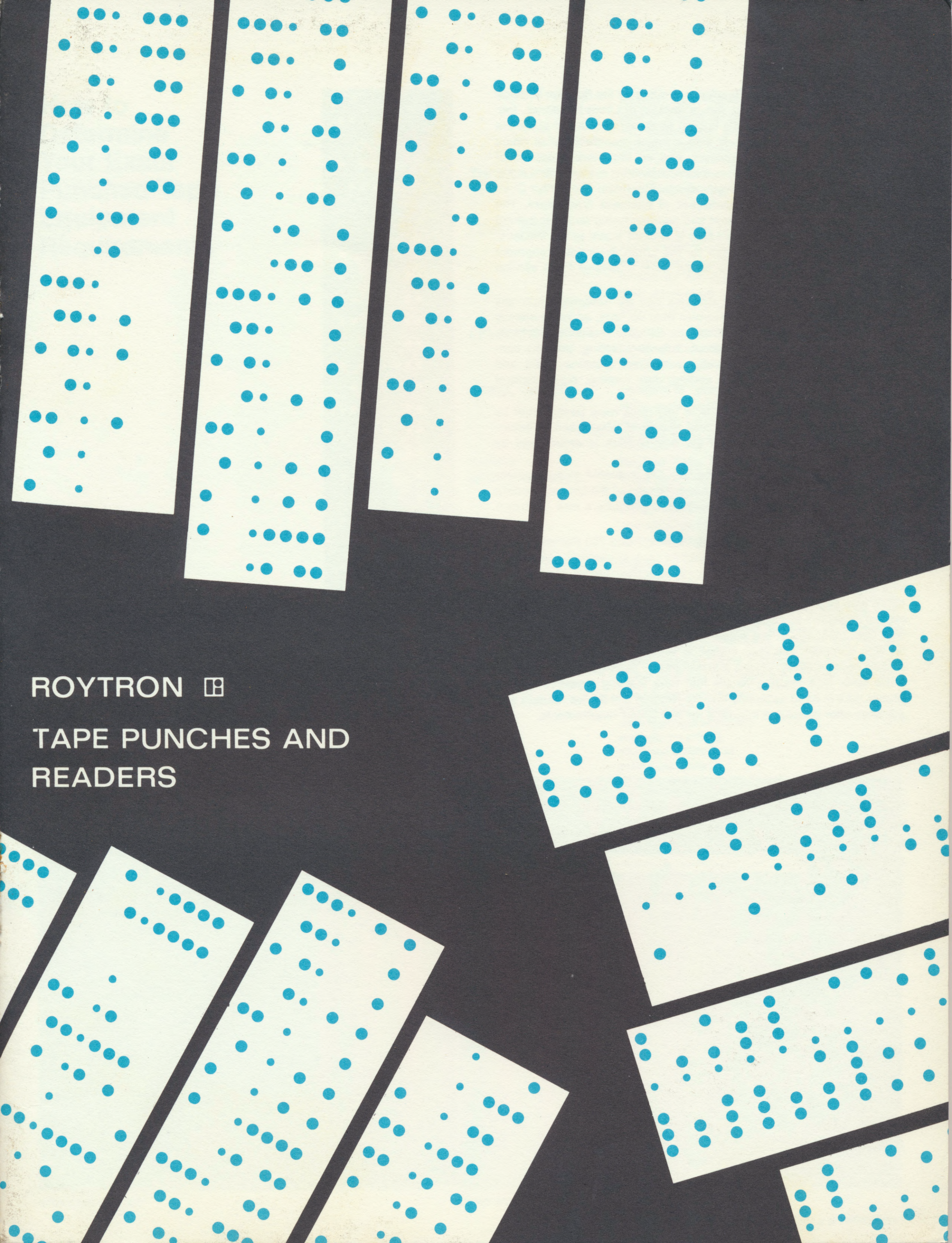



Roytron Tape Punches and Readers are made by the Roytron Division of Royal Typewriter Company, Inc., a division of Litton Industries, Inc.

Litton Industries, the world's largest producer of inertial guidance systems for manned aircraft, is also a major manufacturer of office equipment and business machines, and an important producer of precision electronic components, communications systems, and many other technical and engineering products. The Royal Typewriter Company is the world's leading producer of business typewriters. The combined research, development and manufacturing facilities behind Roytron Tape Punches and Readers is without equal in the industry. The service support as provided by the Litton Business Equipment Service organization gives one of the most extensive local service coverages in the industry.

Roytron Tape Punches and Readers can be integrated into any system where it is feasible to capture data on tape, or automatically control system operation. Applications include: business machines and systems, computer input-output; industrial testing; process control; communications; numerically controlled machine tools and other industrial machines; type setting; data routing; digital control of telemetry; and many others.

Many of the punched tape units in this book have been tested by Underwriters' Laboratories, Inc. and approved when used in equipment where the acceptability of the combination is determined by Underwriters' Laboratories, Inc.

Roytron Tape Punches and Readers are available in a complete range of models for every system need. Advanced design and modern manufacturing methods have combined to produce a new *cost/performance* standard.

**Advanced design features** in the Roytron 500 and 700 Series provide a new high in performance for punched tape equipment • Small, efficient electro-magnets in combination with over-center springs provide smooth, trouble-free punching over an extremely long life • Reluctance type pick up for timing eliminates contacts and cams, reducing system noise and increasing reliability • Bi-directional reader operates with high reliability at low noise level through action of sensing pins on wire contacts. The read station is sealed from dust and environmental contaminants, saving maintenance • Semi-automatic feed on basic desk type readers allows fast tape loading (operator merely places tape in head assembly throat). Roytron 200 Series readers and punches offer simplified interface for low speed requirements.

How to Determine Your Exact Punched Tape Equipment Requirements .....	page 3
Roytron Tape Punches. Features and Specifications,	
Series 500 and 700 .....	4
Tape Punches, Level One, Series 500 and 700 .....	5
Tape Punches, Level Two, Series 500 and 700 .....	6
Tape Punches, Level Three, Series 500 and 700 .....	7
Tape Punches, Level One, Series 200 .....	8
Tape Punches, Level Two, Series 200 .....	9
Roytron Tape Readers. Features and Specifications,	
Series 500 and 700 .....	10
Tape Readers, Level One, Series 500 and 700 .....	11
Tape Readers, Level Two, Series 500 and 700 .....	12
Tape Readers, Level Three, Series 500 and 700 .....	13
Tape Readers, Level One, Series 200 .....	14
Tape Readers, Level Two, Series 200 .....	15
Combination Reader/Punch Units .....	16
Punched Tape Verify-Duplicate System .....	17
Punched Tape Regenerator .....	17
Auxiliary Tape Handling Equipment .....	18
Roytron Sales Representatives .....	19

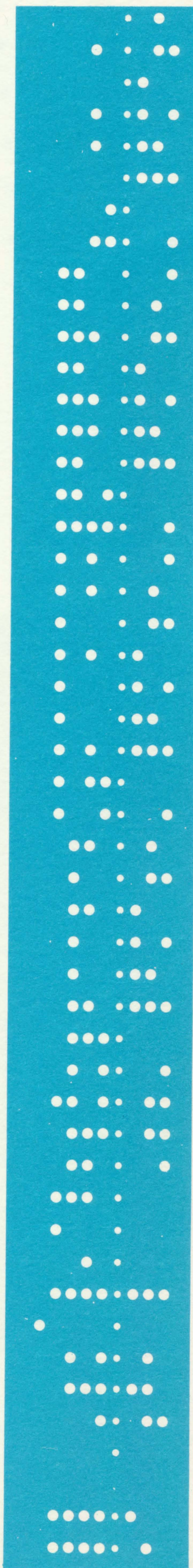



# How to Determine Your Exact Punched Tape Equipment Requirements

## THREE LEVELS

### LEVEL ONE

Roytron Tape Punches and Readers are available in a wide range of models—fifty two in all—to enable you to select the equipment that exactly fulfills your needs.

The punched tape units described in this book are grouped according to their "level" as follows:

LEVEL ONE consists of the basic mechanism only. It has been designed for users who prefer to integrate the mechanism into their own housing, have the means for mechanical drive and timing within their equipment, and wish to supply their own electronic circuitry.

### LEVEL TWO

LEVEL TWO consists of "packaged" units with housing and motor drive, but without electronic logic and circuitry.

### LEVEL THREE

LEVEL THREE consists of "packaged" units complete with all solid state logic and amplifiers. Signal levels are at 0 to -6 volts at low current requirements for easy tie to solid state applications.

## THREE SPEED RANGES

Roytron Tape Punches and Readers come in three speed ranges. The Series 500 models are designed for synchronous operation at 50 cps. Series 700 units are designed for synchronous operation at 75 cps. The Series 200 models are designed for asynchronous operation at 20 cps.

## THREE CONFIGURATIONS

Roytron 500 and 700 Series "packaged" Tape Punches and Readers are offered in three configurations. (1) Rack mounted with integral spoolers. (2) Integrated desk-top Stations, with complete tape handling facilities. (3) Combination Reader/Punch units. Series 200 "packaged" Tape Punches and Readers are available in the desk-top configuration at Level Two only.

*Level Three punches and readers include solid state logic and amplifiers and afford a simple electrical interface to solid state systems.*

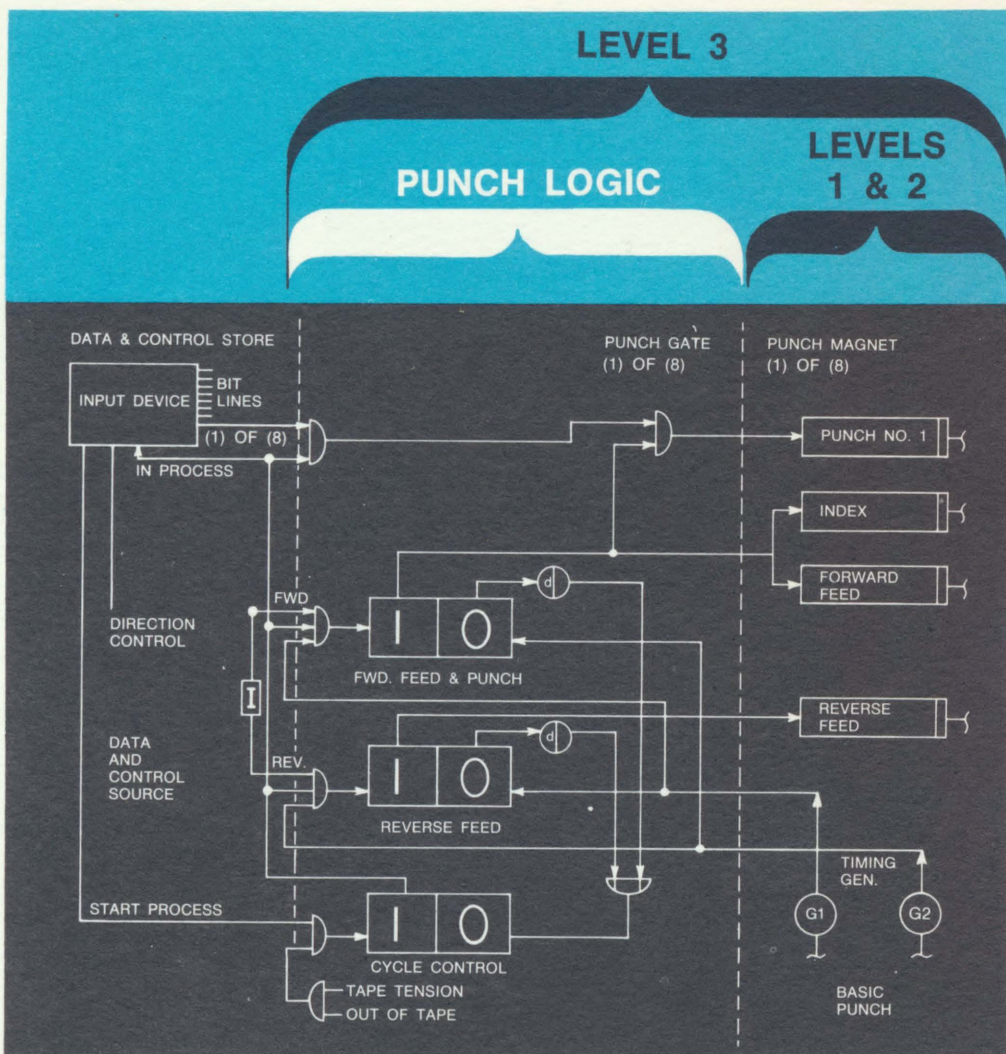

SERIES 500 AND 700

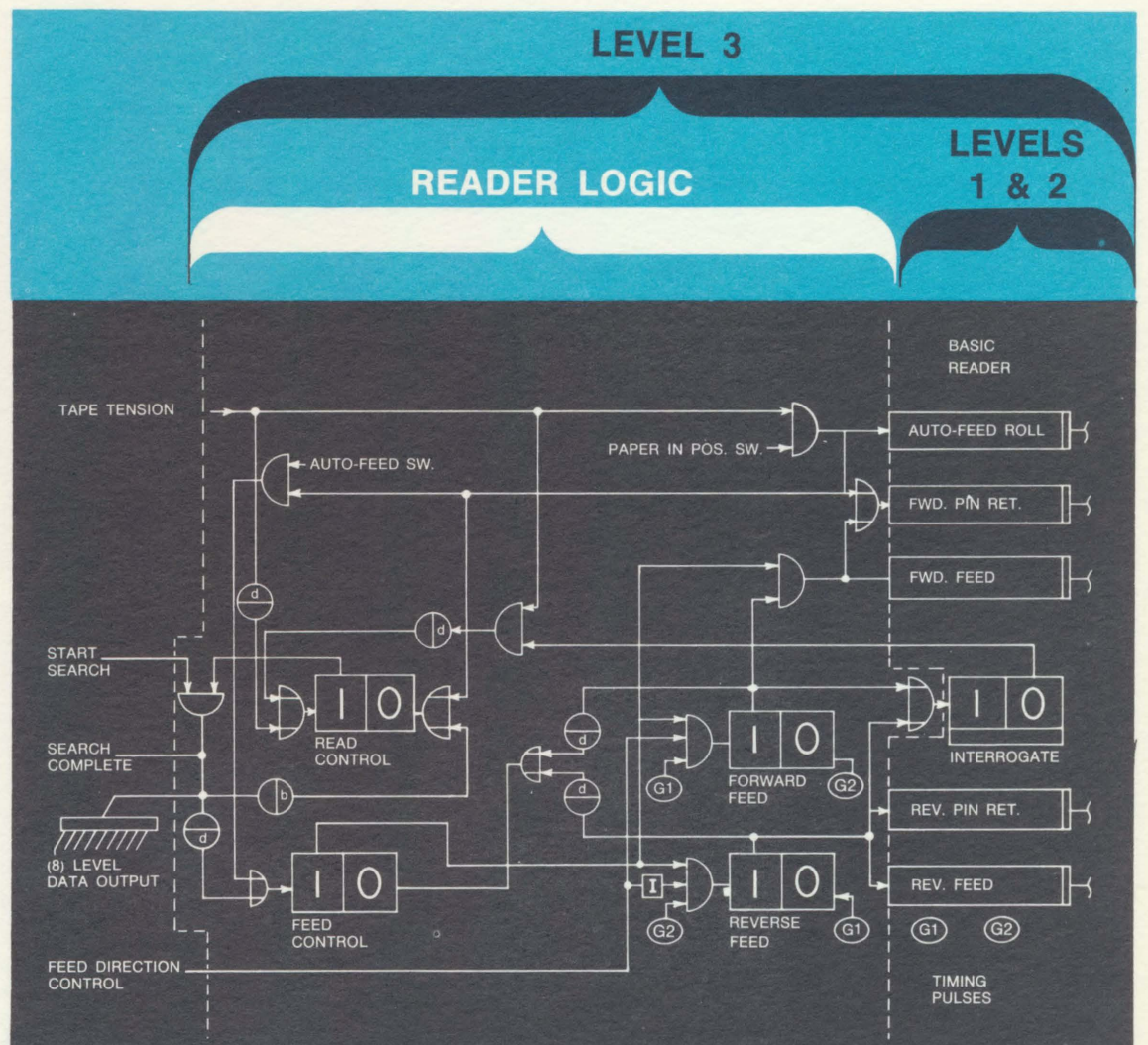

SERIES 500 AND 700



# ROYTRON TAPE PUNCHES

**Tape Drive Sprocket**  
For positive and controlled tape feeding.

**Clear Plastic Punch Cover**  
For observation of the chad action.

**Out of tape switch**

**Adjustable Tape Guide**  
To run 1", 7/8" or 1 1/16" standard tape

**Chad Chute**  
Standard  
Optional

**Optional Features**  
Parity Block  
Manual Tape Feed  
Out of Tape Switch  
Front Chad Chute

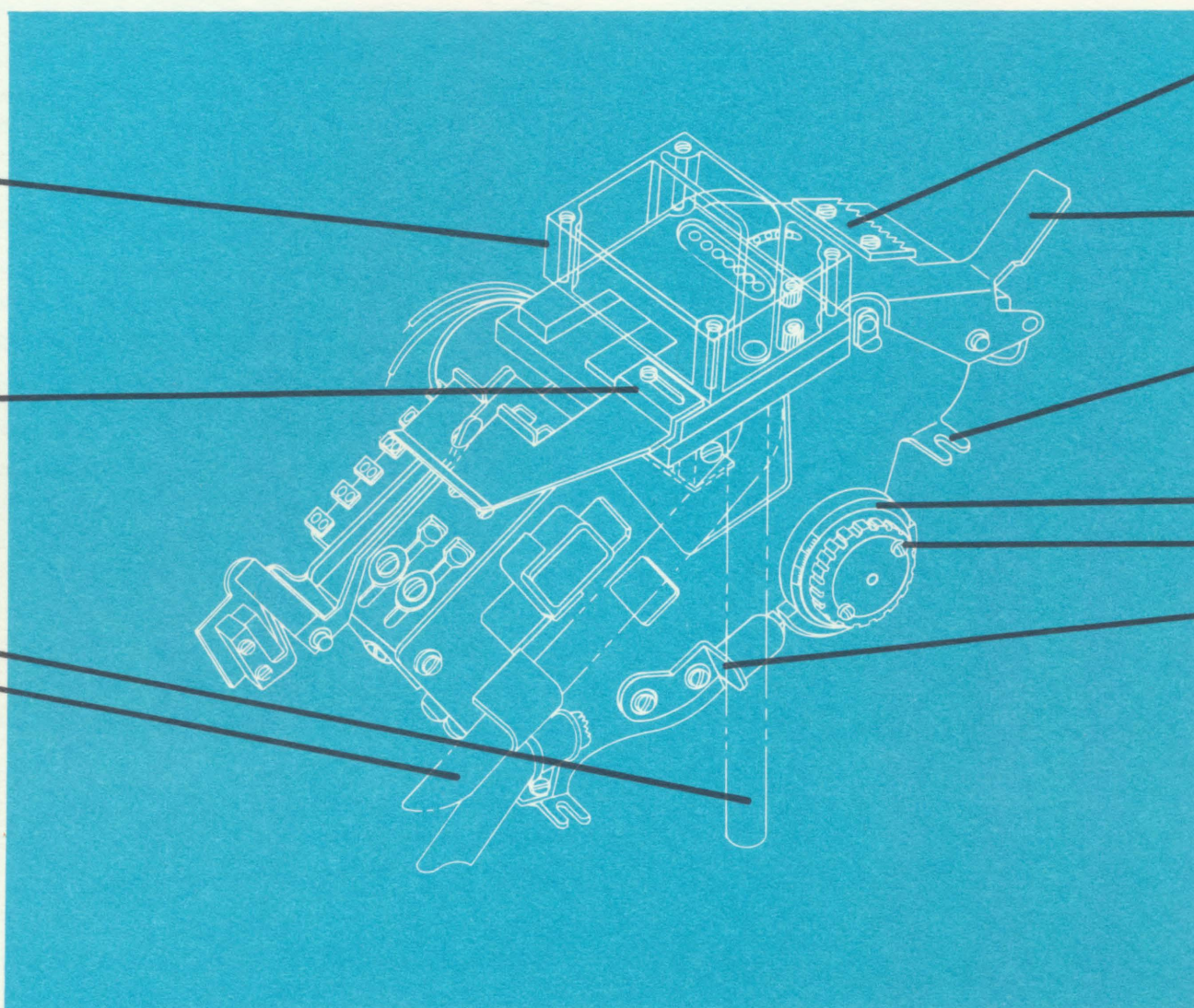

**Tape Tear Plate**  
Insures proper alignment of the tape for automatic feed in Roytron Tape Readers.

**Tape Hold Down**  
Insures engagement of tape with sprocket.

**Mounting Pads (4)**  
Approximate mounting area 6 1/2" long x 3 3/16" wide x 4 1/2" high.

**Calibrated Reference Disc**

**Adjustable Gear Ring**

**Timing Pulse Generator**  
Electrical pulses generated in respect to shaft rotation (See timing chart).

**Input Drive**

**Series 500 (50 cps)**  
3000 RPM  
18 tooth timing gear  
1" diameter.  
Starting torque 4 inch ounces.  
Running torque less than 4 inch ounces.

**Series 700 (75 cps)**  
4500 RPM  
14 tooth timing gear  
.871 diameter.  
Starting torque 4 inch ounces.  
Running torque less than 4 inch ounces.

## FEATURES AND SPECIFICATIONS

### SERIES 500

*Punch Control Solenoids*  
3000 turns No. 39 Formvar  
320 ohms plus or minus 10% at 70° F  
24 VDC plus or minus 10%  
*Forward and Reverse Feed Solenoids*  
1300 turns No. 36 Formvar  
45 ohms plus or minus 10% at 70° F  
24 VDC plus or minus 10%  
(series impedance 68 ohms shunted by 50 microfarads for 50 cps)

### SERIES 700

*Punch Control Solenoids*  
3000 turns No. 39 Formvar  
320 ohms plus or minus 10% at 70° F  
24 VDC plus or minus 10%  
*Forward and Reverse Feed Solenoids*  
800 turns No. 38 Formvar  
20 ohms plus or minus 10% at 70° F  
24 VDC plus or minus 10%  
(series impedance 50 ohms shunted by 50 microfarads for 75 cps)

### SERIES 500 AND 700

- Bi-directional tape feed (punch in forward direction only)
- 5, 6, 7 or 8 level code structure
- 1", 7/8", or 1 1/16" standard tape accommodated by adjustment of variable tape guide
- Operating temperature and humidity 55°-100° F operating; 10°-150° F non-operating 20%-95% w/o condensation—operating 5%-95% w/o condensation—non-operating
- Tension of tape supply equipment not to exceed 6 ounces. (Spring load; low k factor.)

#### Timing Pulse Generator

Pulse generator producing equally spaced positive and negative pulse (one each) for each revolution of the shaft. Pulse amplitude 4.5 volts minimum.  
DC resistance of coils 685 ohms plus or minus 10% at 70° F. 5000 turns of No. 42 Formvar wire. DC bias current required—15 ma.



**LEVEL 1 —  
BASIC  
MECHANISM**

The Roytron basic tape punch mechanism has been designed for OEM users who have the means for mechanical drive and timing within their equipments, and prefer to supply their own circuitry and housing. Dimensions of the unit are: 5 1/2" long x 3 3/16" wide x 4 1/2" high. Weight is approximately 3 1/2 lbs.

The timing chart below depicts the mechanism functions as related to shaft rotation using the negative pulse as a zero reference for angular position. Punch coils and feed coils are energized for one half the cycle at which time the mechanical function is committed to completion and call signals can be removed.

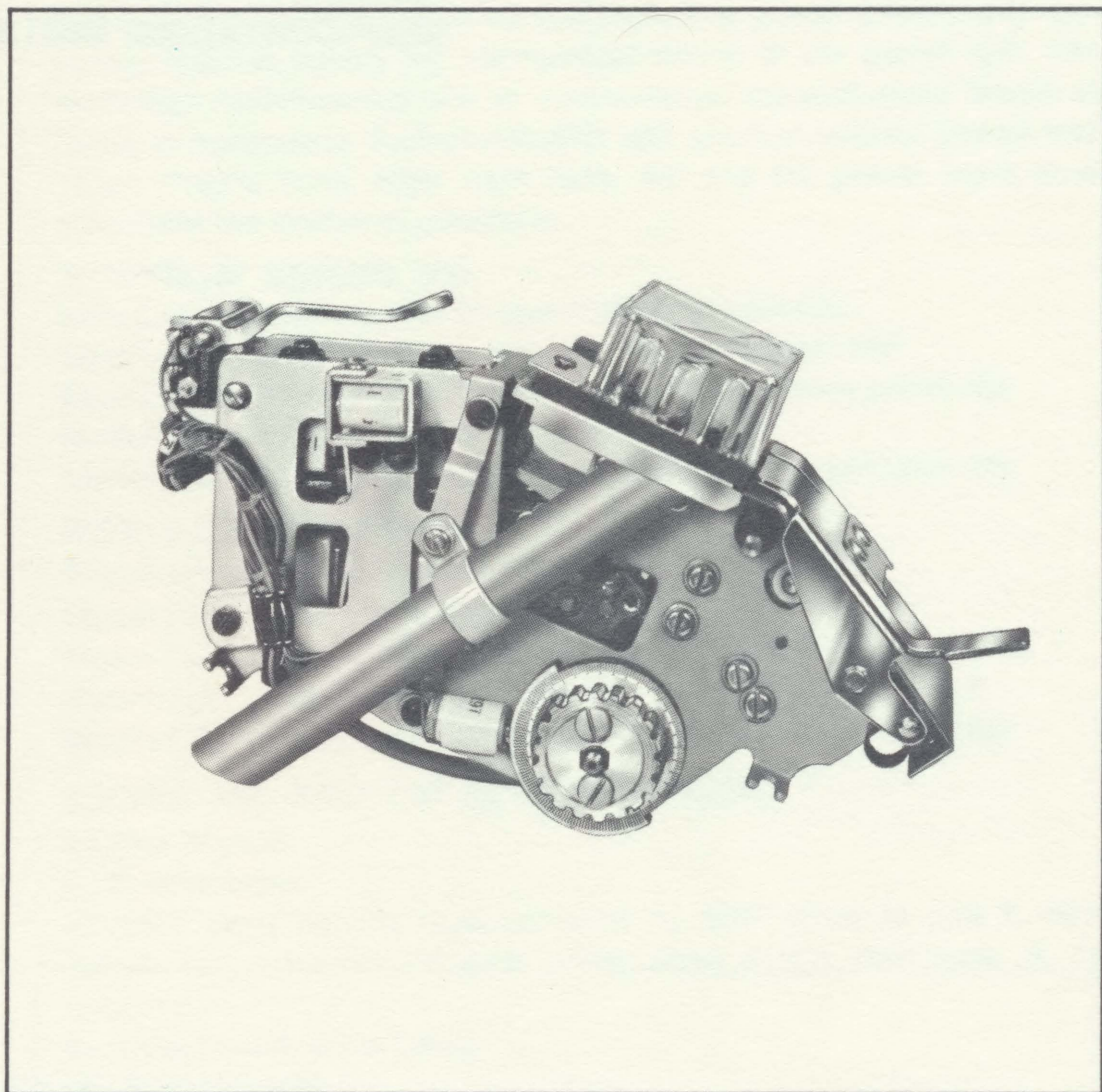

**ROYTRON  
SERIES  
500**

50 Characters Per Second  
Model 500 — Basic punch mechanism  
Model 501 — Incorporates advanced feed hole 6 level die

**ROYTRON  
SERIES  
700**

75 Characters Per Second  
Model 700 — Basic punch mechanism  
Model 701 — Incorporates advanced feed hole 6 level punch die.

**SERIES 500  
AND  
700  
TIMING  
CHART**

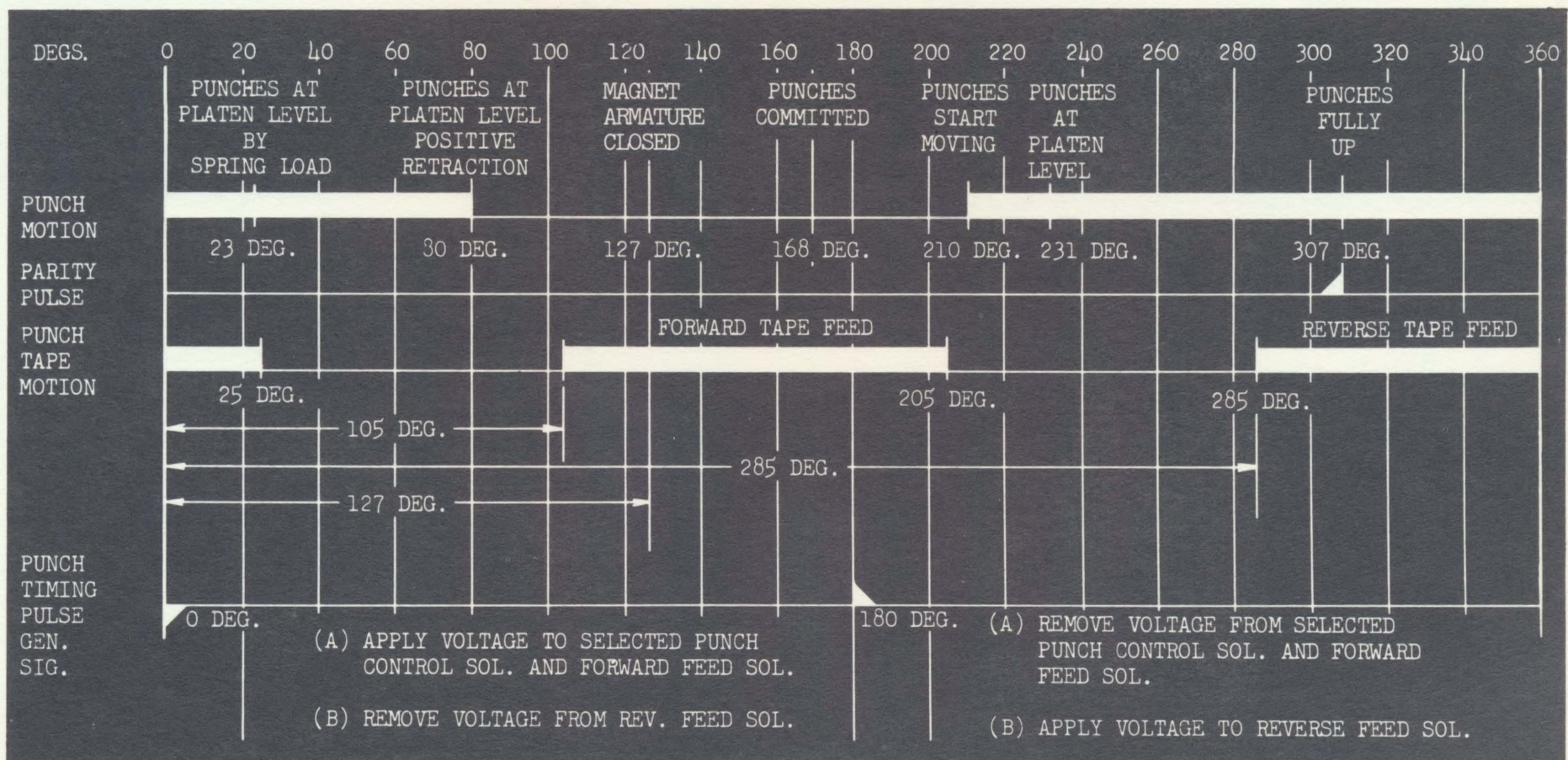



## ROYTRON TAPE PUNCHES LEVEL TWO

### LEVEL 2— SELF-CONTAINED UNITS

Roytron Tape Punches are available in two self-contained configurations to provide flexibility in housing. The models listed below are offered to users who prefer to develop their own logic and circuitry. Control and signal levels are identical to those specified under Level 1 basic mechanisms.

A motor drive, tape feed switch, tape tension switch, and tape handling facilities are incorporated in the desk or rack housing along with the basic mechanism.

#### ROYTRON SERIES 500

Synchronous operation at 50 characters per second.

Model 514 — Rack mounted

Model 515 — Incorporates advanced feed hole 6 level punch die

Model 518 — Integrated Punch Station

Model 519 — Incorporates advanced feed hole 6 level punch die

#### ROYTRON SERIES 700

Synchronous operation at 75 characters per second.

Model 714 — Rack mounted

Model 715 — Incorporates advanced feed hole 6 level punch die

Model 718 — Integrated Punch Station

Model 719 — Incorporates advanced feed hole 6 level punch die

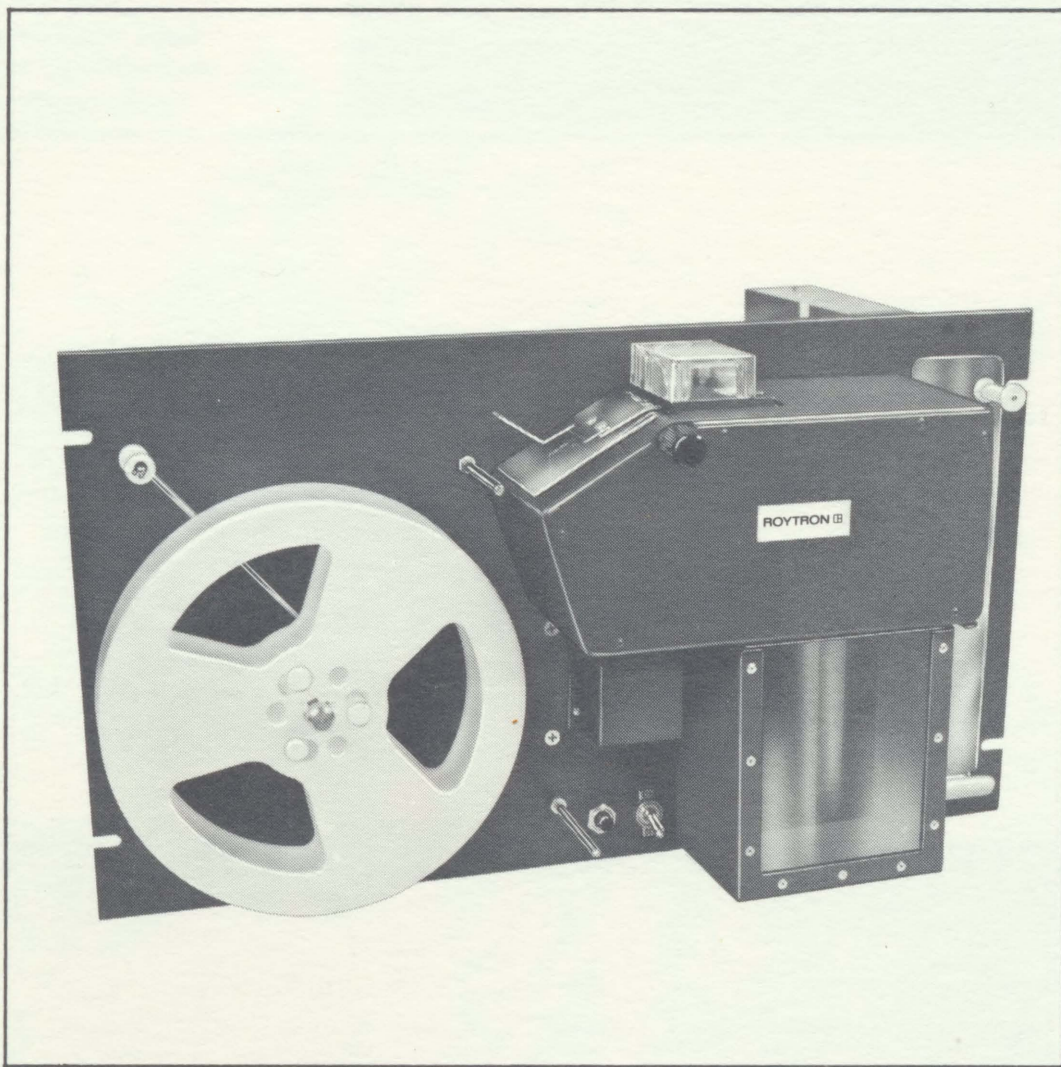

**Series 500 and 700 Rack Mounted Tape Punches** are designed for simple installation on original equipment. Tape Supply, take-up facilities, and chad box are included on the rack mounting. Overall dimensions are: 10½" high x 19" wide x 12" deep. Weight: 23½ lbs. approximately.

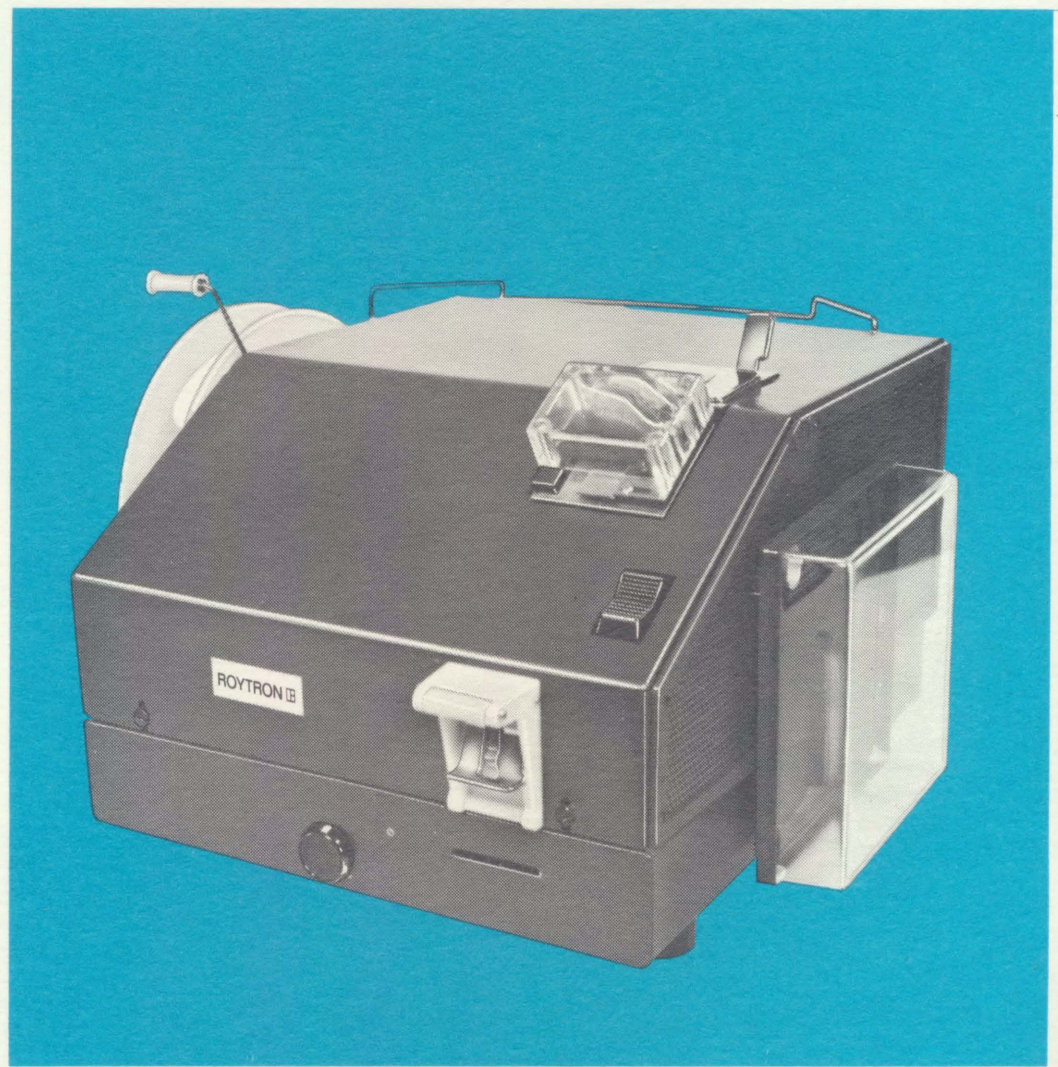

**Series 500 and 700 Integrated Punch Stations** can operate as a complete tape punching facility when cable connected to appropriate signal generating equipment. This configuration includes a standard 8½" tape supply reel in a drawer mounted at the base of the unit. The tape feeds through the punching head and a tape guide (located at the rear) to a side mounted take up reel. Take up reels in either 7½" or 8½" diameters are available. The oversized chad container can accommodate chad from approximately 1000 feet of punched tape. Overall dimensions are: 14½" wide x 15" deep x 9½" high. Weight is approximately 23½ lbs.



## LEVEL 3— SELF-CONTAINED UNITS WITH SOLID STATE LOGIC AND AMPLIFIERS

Roytron Tape Punches of this level are designed for applications requiring a complete punch station including punch drivers and necessary logic to satisfy the mechanical timing of the punch unit. The electrical requirements are at conventional transistorized levels as found in computers, instrumentation and process control equipment. Three control lines, eight data lines, AC and DC power input lines constitute the electrical interface.

### ROYTRON SERIES 500

Synchronous operation at 50 characters per second.

Model 524 — Rack mounted with spooler and supply reel

Model 525 — Incorporates advanced feed hole 6 level punch die

Model 528 — Integrated punch station

Model 529 — Incorporates advanced feed hole 6 level punch die

### ROYTRON SERIES 700

Synchronous operation at 75 characters per second.

Model 724 — Rack mounted with spoolers

Model 725 — Incorporates advanced feed hole 6 level punch die

Model 728 — Integrated punch station

Model 729 — Incorporates advanced feed hole 6 level punch die

### SERIES 500 AND 700 SPECIFICATIONS

#### Control Signals

##### a. 8 Data Lines

Standby input loading approximated by 4000 ohms to plus 6 volts. Punch call required -6 volts swing from 0 volt reference. (8 ma required.)

##### b. 3 Communication Lines

###### (1) Start Process

0 volts from -6 volts reference. Leading edge rise time not to exceed 100 microseconds.

###### (2) Feed Control (Single Line)

a. Reverse: -6 volts from 0 volts reference. Load is 1.2 K ohms to ground.

b. Forward: 0 volts from -6 volts reference. Load is approx. 35 milliamps.

###### (3) In Process

0 volts from negative reference. Signifies time for data lines to be active for correct punching.

#### DC Power Requirements—500 Series

1. -24 VDC plus or minus 10% @ 750 ma max.  
300 ma average (punching four bit pattern)
2. -18 VDC plus or minus 10% delayed 1 ms minimum from -18 VDC
3. -18 VDC plus or minus 10% @ 325 ma max.  
(current includes -18 VDC delayed)
4. + 6 VDC plus or minus 10% @ 160 ma max.

#### DC Power Requirements—700 Series

1. -24 VDC plus or minus 10% @ 800 ma maximum,  
325 ma average (punching four bit pattern)
2. -18 VDC plus or minus 10% @ delayed 1 ms minimum  
from -18 VDC
3. -18 VDC plus or minus 10% @ 325 ma maximum  
(current includes -18 VDC delayed)
4. + 6 VDC plus or minus 10% @ 160 ma max.

#### AC Power Requirements

115 volts AC plus or minus 10% 60 cps. (1/12 hp. motor Series 700) (1/40 hp. motor Series 500) AC Relays 685 ohms. 24 VDC interlocked with source of AC power.

#### OPTIONAL FEATURES

- 220 Volt AC motor
- Parity check (odd or even)
- Out-of-tape switch
- Full reel detector (level 2 rack mounted models)
- Manual tape feed control
- 48 Volt coils (level one and two models)
- Null feed (level 3 rack mounted models)
- Single character storage

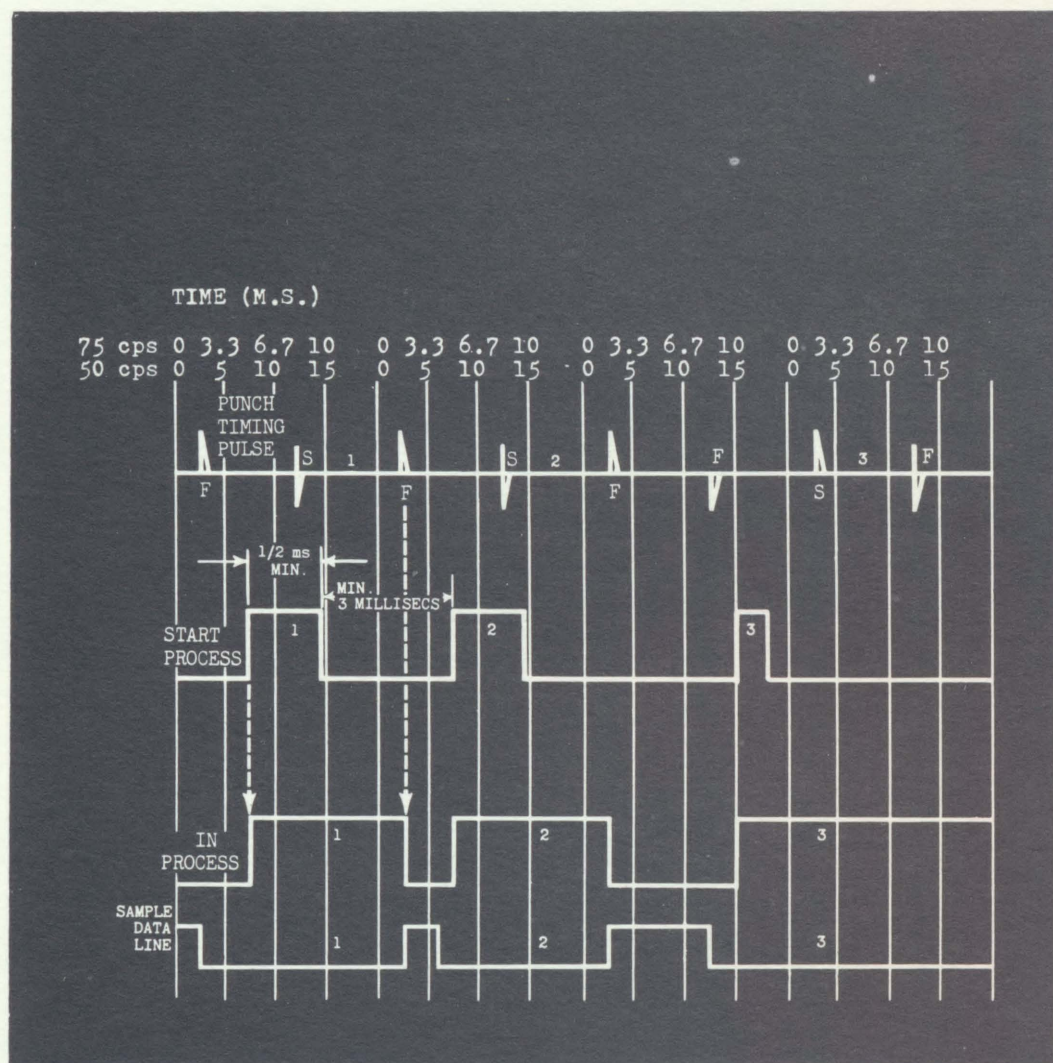

**SERIES  
500 AND  
700  
TIMING  
CHARTS**



# ROYTRON TAPE PUNCHES—SERIES 200 LEVEL ONE

**Clear Plastic Punch Cover**  
For observation of the chad action

**Adjustable Tape Guide**  
To run 1", 7/8" or 11/16" standard tape

**Tape Drive Sprocket**  
For positive and controlled tape feeding

**Calibrated Reference Disc**

**Out of Tape Switch**  
(optional)

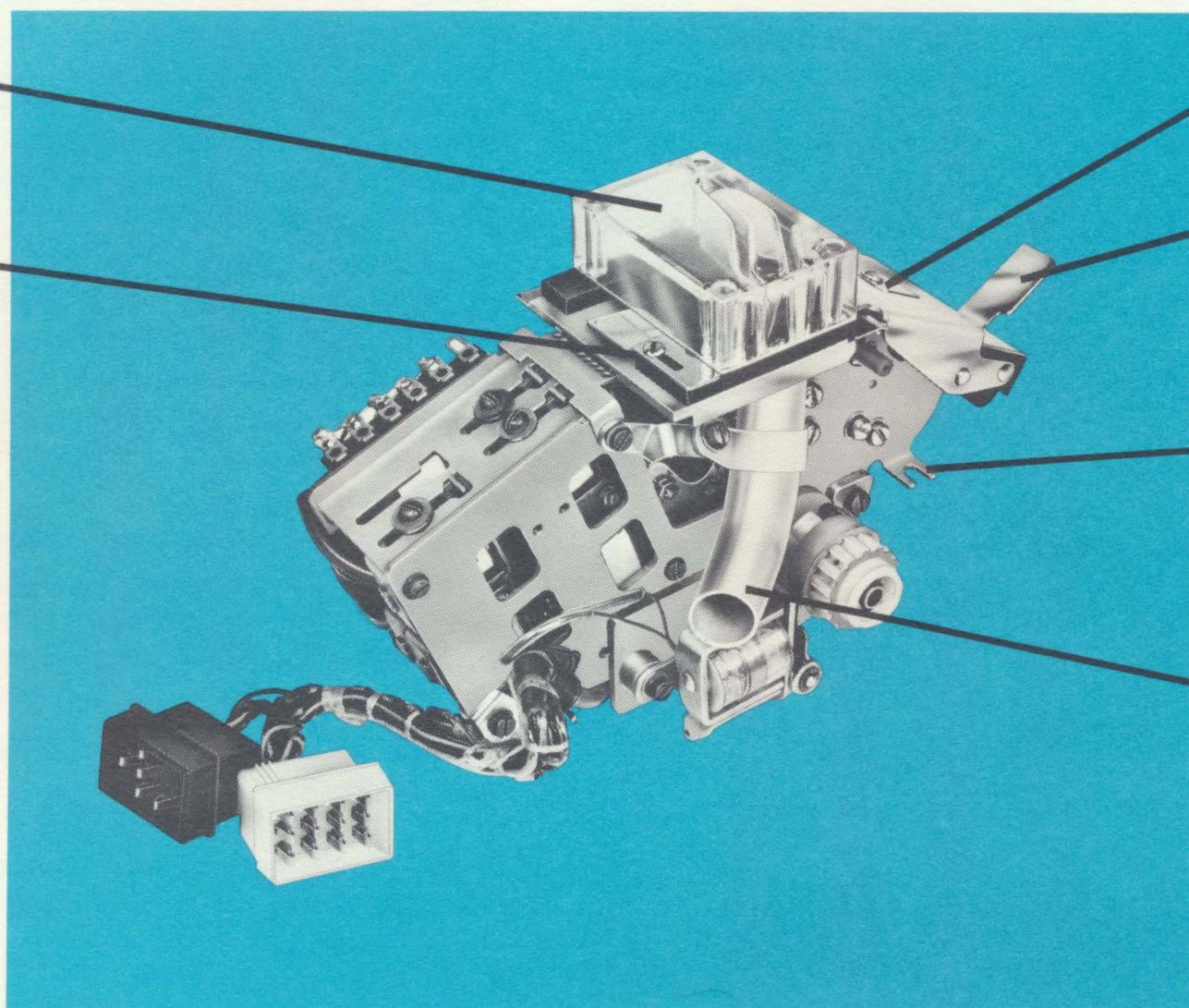

**Tape Tear Plate**  
Insures proper alignment of the tape for automatic feed in Roytron tape readers

**Tape Hold Down**  
Insures engagement of tape with sprocket

**Mounting Pads (4)**  
Approximate mounting area 6-1/2" long x 3-3/16" wide x 4-1/2" high

**Chad Chute**

**Optional Features**  
Parity Block  
Manual Tape Feed  
Out of Tape Switch  
Front Chad Chute

## MODEL 200 TAPE PUNCH MECHANISM

The Roytron Model 200 is a tape perforator that will punch tape in accordance with recommended *Proposed American Standard for Perforated Paper Tape*, at a rate of 17 cps asynchronously and at 23 cps synchronously. The Model 200 is uni-directional, with an integral tape feeding mechanism normally disengaged to allow punching without feeding tape or moving tape with the manual tape feed knob. The index hole punch is constantly engaged in this device, and punches an index hole for every rotation of the eccentric shaft.

Five optional cam operated switches are available to control the input shaft clutch, tape feed and punch control solenoid, or to provide timing signals to external equipment. The cams are fastened directly to the input shaft and are driven at 1400 RPM.

## FEATURES AND SPECIFICATIONS

### OPERATION

*Rate*—asynchronously to 17 cps and synchronously at 23 cps.

*Feed*—Uni-directional

*Tape*—5, 6, 7 or 8 level code structure. 1", 7/8" or 11/16" standard tape accommodated by adjustment of variable tape guide.

### MECHANICAL

*Input Shaft Requirements*

Starting Torque—4 inch oz.

Speed—1400 RPM

Drive Pulley—1/5 pitch, 15 tooth

Timing Belt Pulley—U.S. Rubber Co. XL-025 recommended.

### TAPE TENSION AND FEED

Maximum tension of tape should not exceed 6 oz.

### CHAD DISPOSAL

Side chad ejection shown. Front chad ejection at front right corner of unit optional.

### ELECTRICAL

*Feed Control Solenoid*  
2350 turns No. 39 single formvar.  
160 OHMS plus-minus 10% at 70 degrees F.  
24 VDC plus-minus 10%.

*Clutch Control Solenoid*  
2000 turns No. 33 single formvar.  
55 OHMS plus-minus 10% at 70 degrees F.  
24 VDC plus-minus 10%. (Series impedance 50 OHMS shunted by 50 microfarad capacitor).

*Punch Control Solenoids*  
3000 turns No. 39 single formvar.  
320 OHMS plus-minus 10% at 70 degrees F.  
24 VDC plus-minus 10%

### Interfacing

Wiring terminates at two 12 pin connectors. Mating Connectors and pins are supplied by manufacturer.

### Environmental

Operating temperature and humidity 55° to 100° F operating; 10° to 150° F non-operating.

20% to 95% without condensation: operating

5% to 95% without condensation: non-operating



**MODEL 218  
INTEGRATED  
PUNCH STATION**

The Model 218 Integrated Punch Station provides a complete tape punching facility. This configuration includes a standard 8 1/2" tape supply reel in a drawer mounted at the base of the unit. The tape feeds through the punching head and a tape guide (located at the rear) to a side mounted take-up reel. Take-up reels in either 7 1/2" or 8 1/2" diameters are available. The oversize chad container can accommodate chad from approximately 1000 feet of punched tape. Overall dimensions are: 14 1/2" wide x 15" deep x 9 1/2" high. Weight is approximately 23 1/2 lbs.

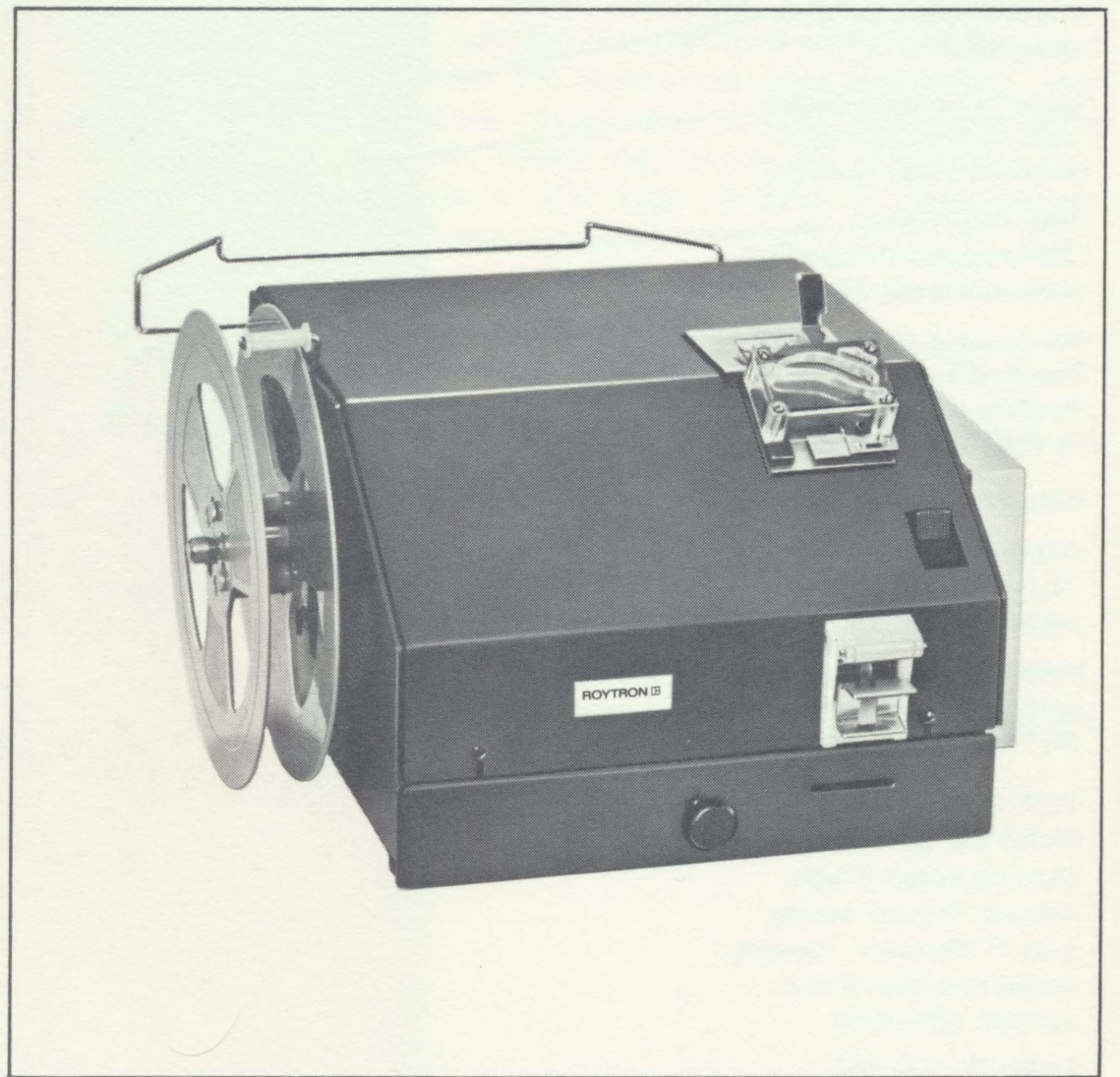

**SERIES 200  
PUNCH  
TIMING  
CHART**

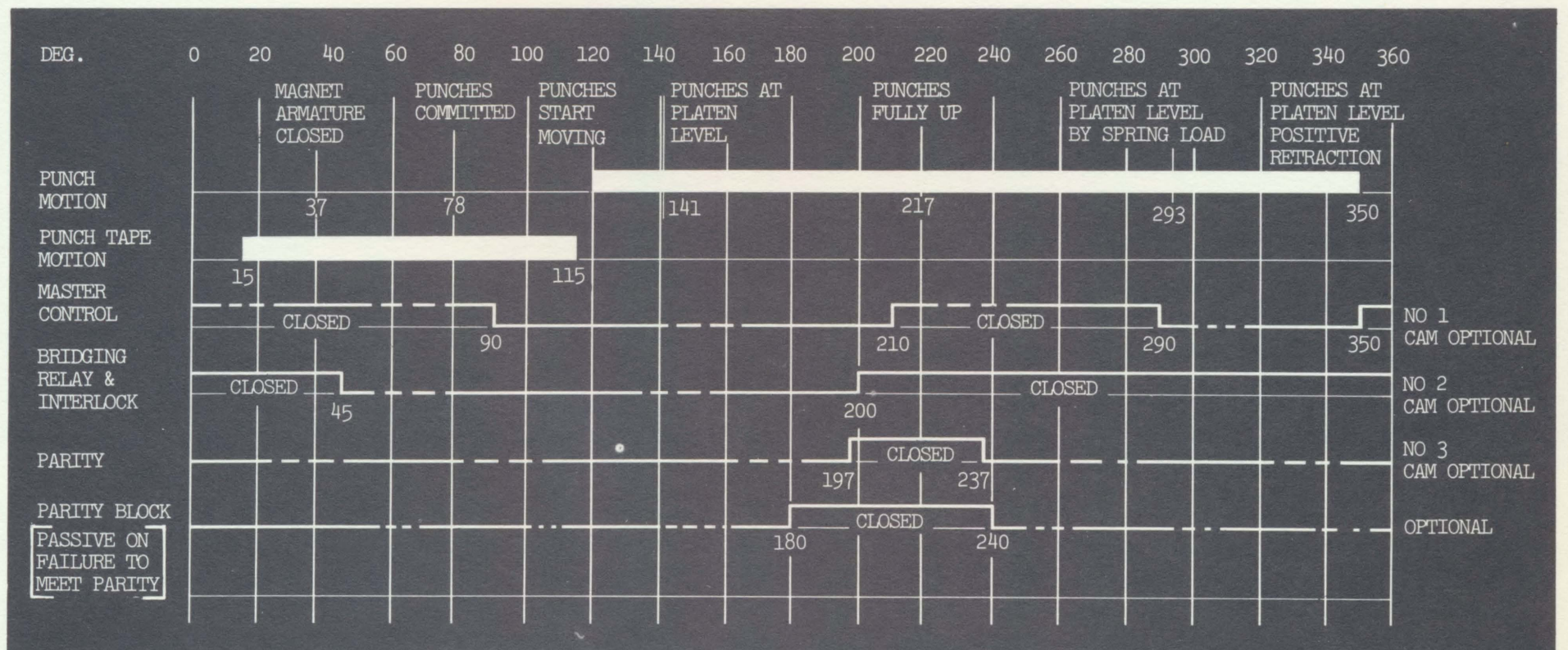



# ROYTRON TAPE READERS

- Detent**  
For controlled indexing of the tape
- Paper in Position Switch**  
Used to terminate semi-automatic feed function
- Auto-Feed Switch**  
Starts sprocket drive for semi-automatic feed function
- Pin Sensing of Punched Tape**  
Positive reading by pins through punched holes
- Auto-Feed Drive Roll**
- Adjustable Tape Guide**  
To run 1", 7/8" or 1 1/16" standard tape
- Mounting Pads (4)**  
Approximate mounting area 5 1/2" long x 3 3/8" wide x 4 1/2" high
- Input Drive**  
**Series 500 (50 cps)**  
Starting torque 3 inch ounces. 18 tooth timing gear 1" diameter. Running torque less than 3 inch ounces. 3000 RPM  
**Series 700 (75 cps)**  
Starting torque 3 inch ounces. 14 tooth timing gear .871 diameter. Running torque less than 3 inch ounces. 4500 RPM

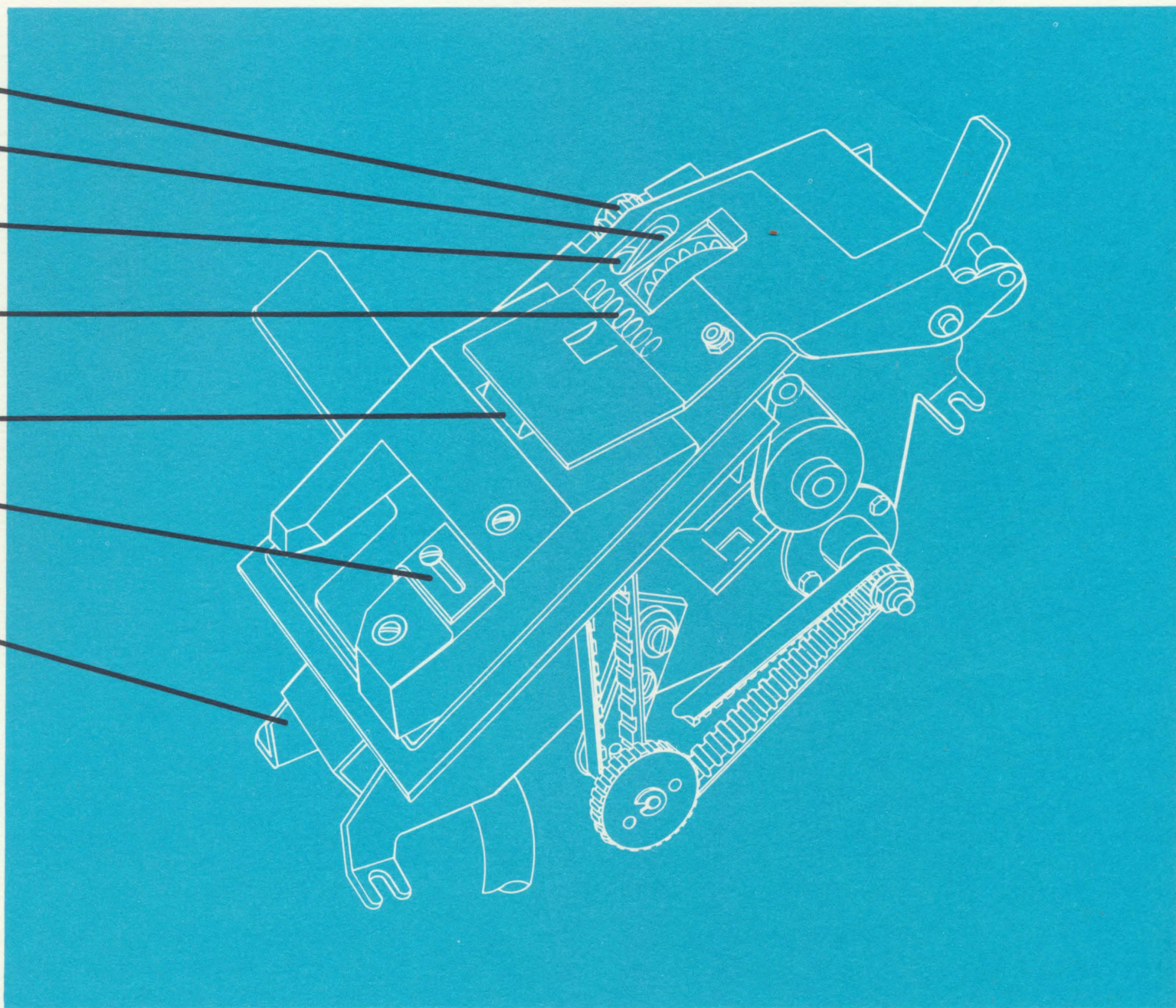

## FEATURES AND SPECIFICATIONS

Roytron Tape Readers operate by action of mechanical sensing pins on a set of wire contacts. An additional interrogate pin acts as a strobe, increasing reliability and reducing noise on output signal. The read station is sealed from dust and environmental contaminants. An exclusive semi-automatic feed on desk mounted units allows fast tape loading. The operator merely places the end of the tape in the head assembly throat. A capstan roller automatically engages and drives the tape to the read station, correctly positioned to receive commands.

### ELECTRICAL SPECIFICATIONS

#### Sensing and Interrogation Contacts

- (a) Make and/or break 50 volts @ 50 ma (resistive).
- (b) Continuous current capacity 500 ma (resistive).
- (c) Total current on continuous basis not to exceed 1 amp. (Silver plated .010" diameter wire contacts. 3 wires per contact loaded to 9 grams per wire. Silver plated brass common rotates incrementally with each tape feed.)

#### Series 500

##### Forward and Reverse Feed Solenoids

##### Forward and Reverse Pin Retracting Solenoids

- (a) Coils 1300 turns of No. 36 Formvar. 45 ohms plus or minus 10% at 70°F.
- (b) Voltage 24 VDC plus or minus 10% (series impedance 68 ohms shunted by 50 microfarad capacitor for pin retraction solenoids, 68 ohms for feed solenoids—based on 50 cps).

#### Series 700

##### Forward and Reverse Feed Solenoids

Solenoids same as Series 500 (series impedance 68 ohms shunted by 50 microfarad capacitor for 75 cps).

##### Forward and Reverse Pin Retracting Solenoids

- (a) 500 turns of No. 32 Formvar. 7 ohms plus or minus 10% at 70°F.
- (b) Voltage 24 VDC plus or minus 10%. (Series impedance 50 ohms shunted by 50 microfarad capacitor for 75 cps).

#### Series 500 and 700

##### Timing Pulse Generator

- (a) Pulse generator producing equally spaced positive and negative pulse (one each) for each revolution of shaft rotation. Pulse amplitude 4.5 volts positive, 4.5 volts negative minimum.
- (b) DC resistance of coils 685 ohms plus or minus 10% @ 70°F. 5000 turns of No. 42 Formvar wire. DC bias current required—15 ma.

##### Semi-automatic Tape Feed Solenoid

Phillip's Control type 42 115 ohms plus or minus 10% @ 70°F. Voltage 24 VDC plus or minus 10%.

- Bi-directional read and feed.
- 5, 6, 7 or 8 bit code structure.
- 1", 7/8", or 1 1/16" standard tape accommodated by adjustment of variable tape guide.
- Operating temperature and humidity. 55°-100°F operating; 10°-150°F non-operating 20%-95% w/o condensation—operating 5%-95% w/o condensation—non-operating Tension of tape supply equipment should not exceed 6 ounces. (Spring load: low K factor.)



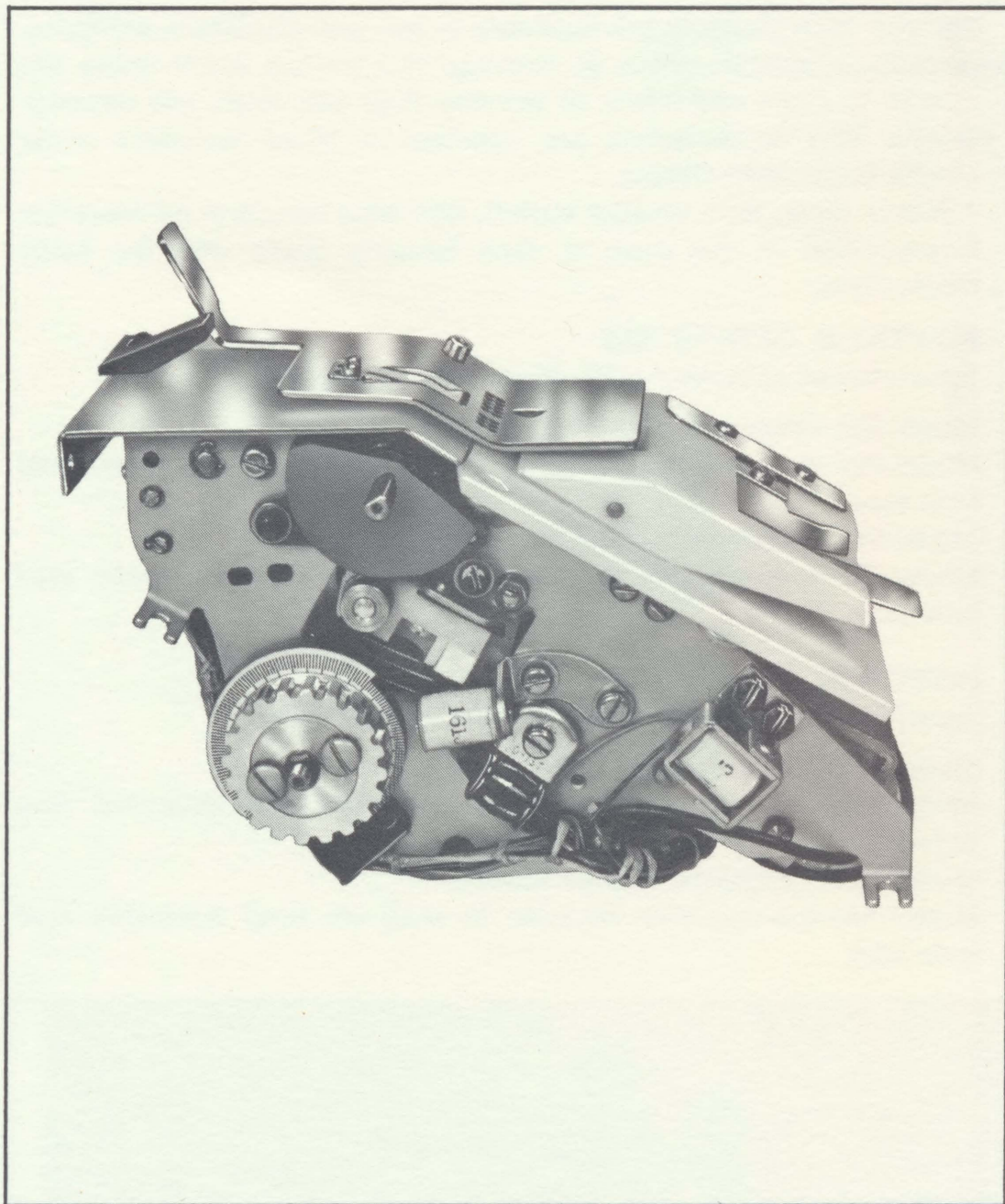

**LEVEL 1 –  
BASIC  
MECHANISM**

The Roytron basic tape reader mechanism can be installed in equipments containing their own means for mechanical drive and timing. Four models are available. Overall dimensions of the basic reader mechanism are: 5 1/2" long x 3 1/8" wide x 4 1/2" high. Weight is approximately 3 1/2 lbs.

**ROYTRON  
SERIES  
500**

Synchronous operation at 50 cps

Model 550—Basic reader mechanism  
Model 551—Incorporates features to read six level advanced feed hole tape

**ROYTRON  
SERIES  
700**

Synchronous operation at 75 cps

Model 750—Basic reader mechanism  
Model 751—Incorporates features to read six level advanced feed hole tape

**SERIES 500  
AND  
700  
TIMING  
CHART**

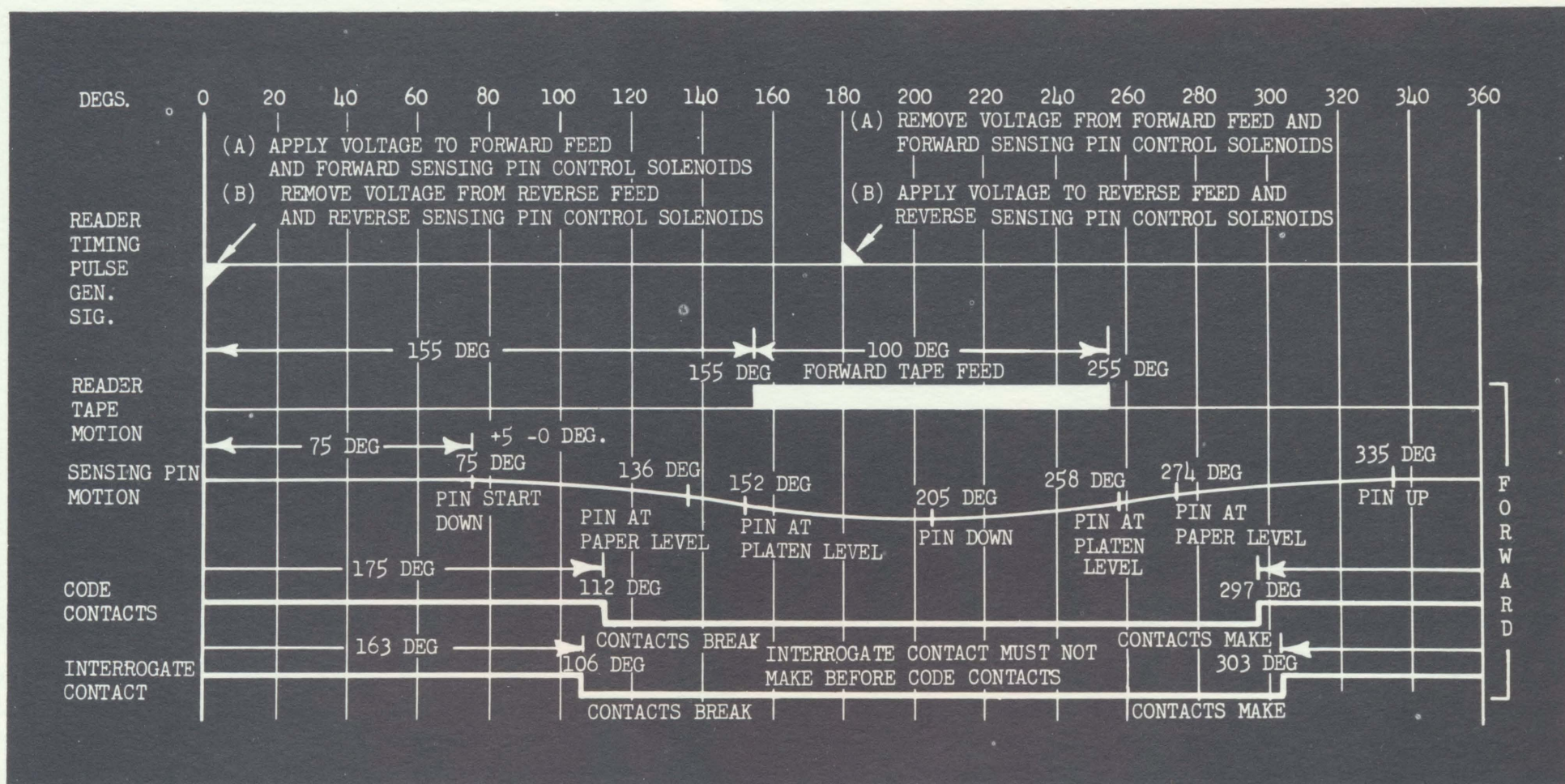

The timing chart to the right shows the reader mechanical functions as related to shaft rotation using the negative pulse as zero reference. Coils are energized for one half the time of a single shaft revolution.



## LEVEL 2— SELF-CONTAINED UNITS

Roytron Tape Readers are available in two self-contained configurations to provide flexibility in housing. The models listed below are offered to users who prefer to develop their own logic and circuitry. Control and signal levels are identical to those specified under Level 1 basic mechanisms.

A motor drive, tape tension switch, and tape handling facilities are incorporated in the desk or rack housing along with the basic mechanism.

### ROYTRON SERIES 500

Synchronous operation at 50 characters per second

Model 564—Rack mounted with spoolers

Model 565—Incorporates features to read six level advanced feed hole tape

Model 568—Integrated reader station

Model 569—Incorporates features to read six level advanced feed hole tape

### ROYTRON SERIES 700

Synchronous operation at 75 characters per second

Model 764—Rack mounted with spoolers

Model 765—Incorporates features to read six level advanced feed hole tape

Model 768—Integrated Reader Station

Model 769—Incorporates features to read six level advanced feed hole tape

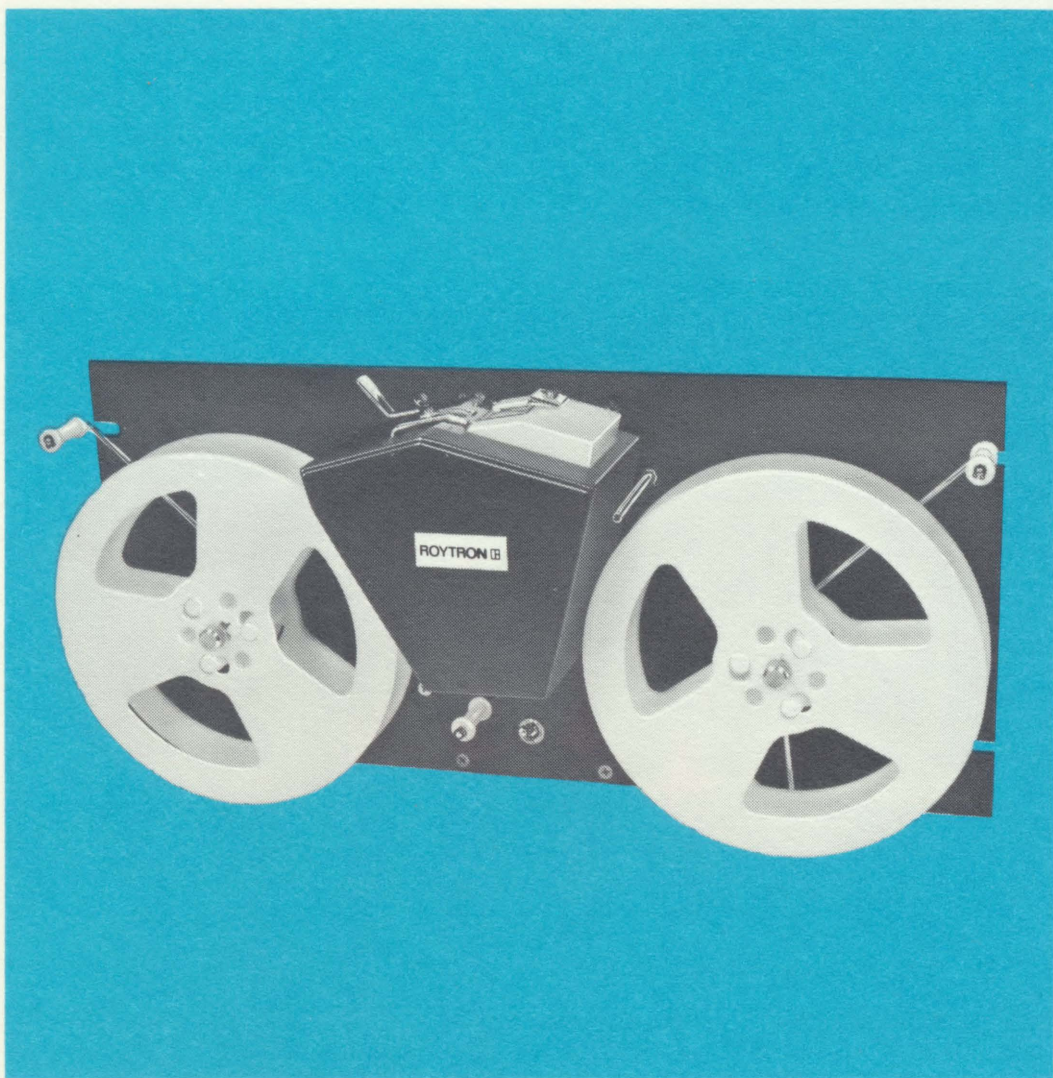

**Roytron Series 500 and 700 Rack Mounted Readers and Spoolers** are designed for simple installation on original equipment where automatic operation is desired. Overall dimensions are: 8<sup>3</sup>/<sub>4</sub>" high x 19" wide x 8<sup>1</sup>/<sub>2</sub>" deep. Reels are 7<sup>1</sup>/<sub>2</sub>". Weight: Approximately 23<sup>1</sup>/<sub>2</sub> lbs.



**Roytron Series 500 and 700 Integrated Read Stations** can operate as a complete tape read facility. In this configuration, an 8<sup>1</sup>/<sub>2</sub>" reel of punched tape is placed into the drawer mounted at the base of the unit. The tape feeds through the read head and a tape guide (located at the rear) to a side mounted take up reel. Take up reels in either 7<sup>1</sup>/<sub>2</sub>" or 8" diameters are available. Overall dimensions are: 13<sup>1</sup>/<sub>2</sub>" wide x 15" deep x 9<sup>1</sup>/<sub>2</sub>" high. Weight is approximately 23<sup>1</sup>/<sub>2</sub> lbs.



**LEVEL 3—  
SELF-CONTAINED UNITS  
WITH  
SOLID STATE LOGIC  
AND AMPLIFIERS**

Roytron Tape Readers of this level are designed for applications requiring a complete read station, including motor drive and transistorized logic circuitry.

**ROYTRON SERIES 500**

Synchronous operation at 50 characters per second

Model 574—Rack mounted with spoolers

Model 575—Incorporates features to read six level advanced feed hole tape

Model 578—Integrated reader station

Model 579—Incorporates features to read six level advanced feed hole tape

**ROYTRON SERIES 700**

Synchronous operation at 75 characters per second

Model 774—Rack mounted with spoolers

Model 775—Incorporates features to read six level advanced feed hole tape

Model 778—Integrated Reader Station

Model 779—Incorporates features to read six level advanced feed hole tape

**SERIES 500 AND 700 SPECIFICATIONS**

**Control Signals:**

**a. 8 Data Lines**

0 volts gated output from -18 volt reference 50 ma available per line. Contingent upon (1) hole in tape, (2) call for read-out, (3) tape in position from previous paper feed cycle.

**b. Communication Lines**

**(1) Start Search**

0 volts from -6 volt reference. Leading edge calls for read-out. Trailing edge initiates feed cycle. Edge rise and fall times not to exceed 1/4 millisecond.

**(2) Feed Control (Single Line)**

Reverse: -6 volts from 0 volts reference. Load is 1.2K to ground. Forward: 0 volts from -6 volts reference. Load is approx. 35 milliamps.

**(3) Search Complete**

0 volts from negative reference not to exceed -18 volts. This line acts as a strobe for reader data lines. Line is active until trailing edge of start search.

**DC Power Requirements—Series 500**

- 24 VDC plus or minus 10% 500 ma maximum, 225 ma average.
- 18 VDC plus or minus 10% delayed 1 ms minimum from -18 VDC
- 18 VDC plus or minus 10% 450 ma maximum (current includes -18 VDC delayed)
- + 6 VDC plus or minus 10% @ 80 ma max.

**DC Power Requirements—Series 700**

- 24 VDC plus or minus 10% @ 1200 ma maximum, 400 ma average
- 18 VDC plus or minus 10% @ delayed 1 ms from -18 VDC
- 18 VDC plus or minus 10% @ 450 ma maximum (current includes -18 VDC delayed)
- +6 VDC plus or minus 10% @ 80 ma max.

**AC Power Requirements**

AC 115 volts AC 60 cps.

1/20 hp. motor (700 Series).

1/40 hp. motor (AC relay 645 ohms. 24 VDC supply interlocked with source of AC Power).

- 220 Volt AC motor
- Bi-directional spoolers
- 48 Volt coils (level one and two models)

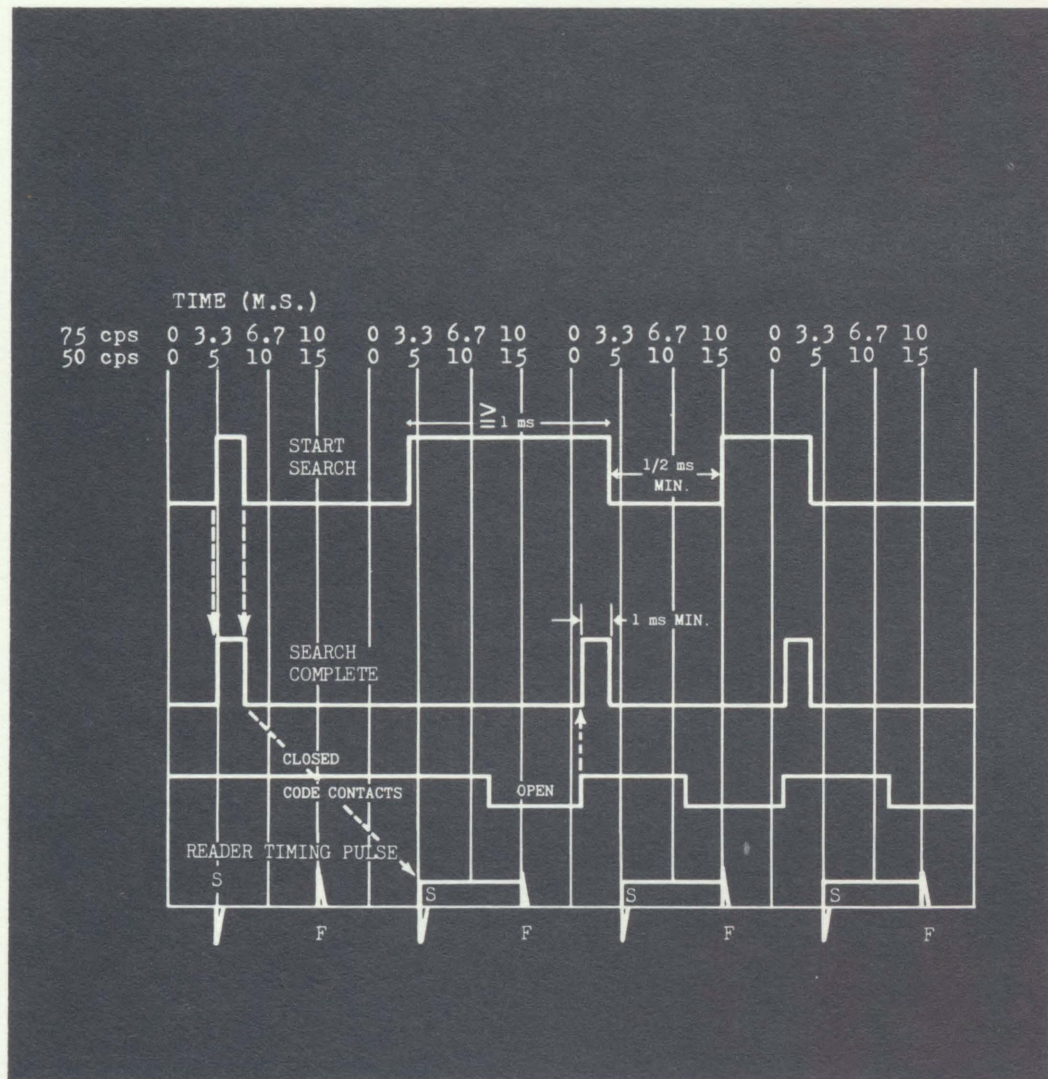

**SERIES  
500 AND  
700  
TIMING  
CHART**

**OPTIONAL FEATURES**



**Auto-Feed Switch**  
Starts sprocket drive for semi-automatic feed function

**Pin Sensing of Punched Tape**  
Positive reading by pins through punched holes

**Auto-Feed Drive Roll**

**Adjustable Tape Guide**  
To run 1", 7/8" or 11/16" standard tape

**Detent**  
For controlled indexing of the tape

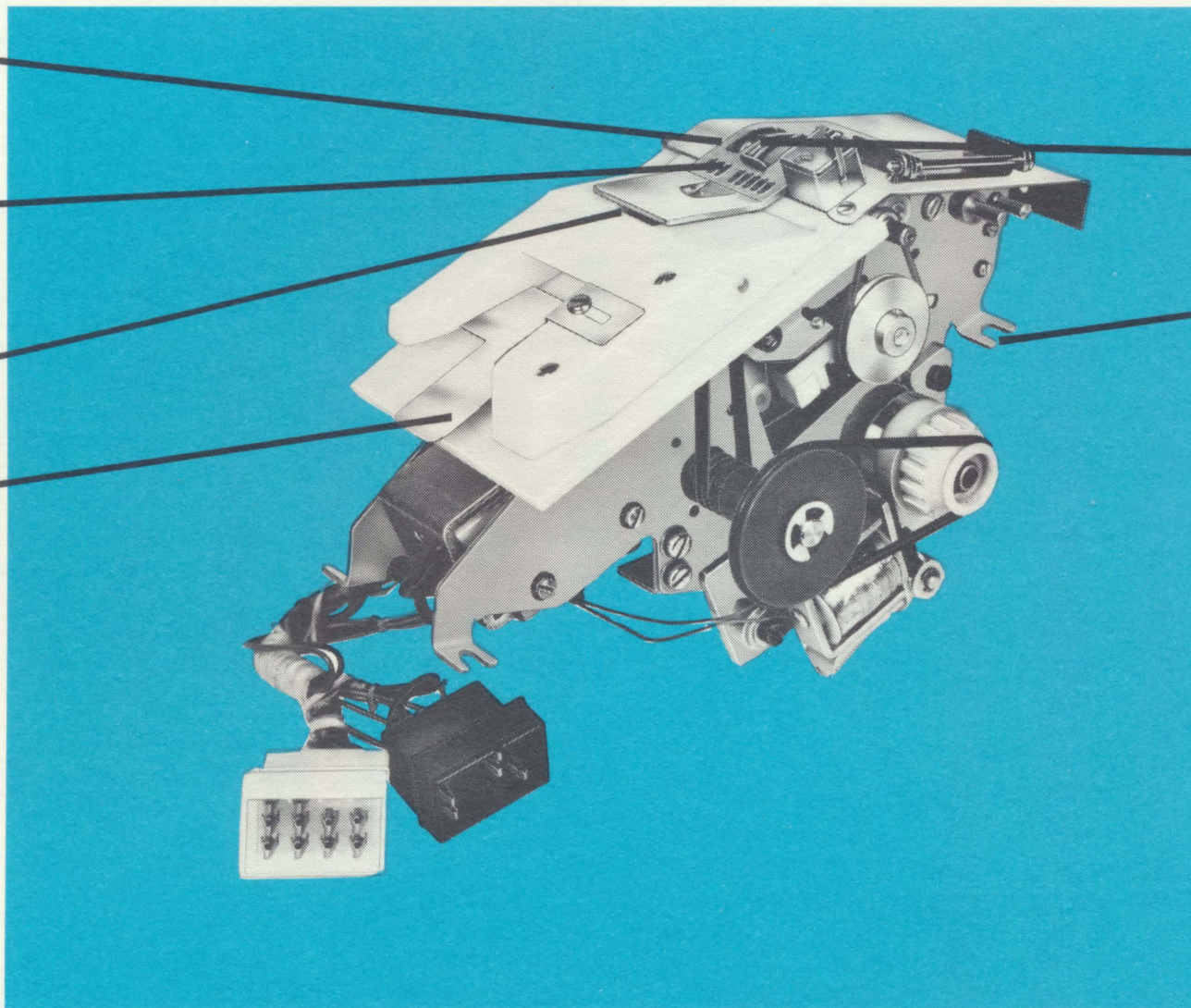

**Paper in Position Switch**  
Used to terminate semi-automatic feed action

**Mounting Pads (4)**  
Approximate mounting area 5-1/2" long x 3-1/8" wide x 4-1/2" high

**MODEL 250 TAPE READER MECHANISM**

The Roytron Model 250 uni-directional perforated tape reader is a pin sensing-wire contact reader designed to read paper or mylar tapes. The reader features a unique semi-automatic feed device that offers the optimum of ease and speed in loading the perforated tape.

Five optional cam-operated timing switches are available for the reader to control the input shaft clutch, interrogate the code contacts or to provide timing signals from the reader to the user's equipment. The cams are connected to the input shaft and are driven at 1400 RPM.

**FEATURES AND SPECIFICATIONS**

**OPERATION**

*Rate*—Asynchronously to 17 cps and synchronously at 23 cps.  
*Feed*—Uni-directional  
*Tape*—5, 6, 7 or 8 level code structure. 1", 7/8" or 11/16" standard tape accommodated by adjustment of variable tape guide.

**MECHANICAL**

*Input Shaft Requirements*  
Starting Torque—4 inch oz.  
Speed—1400 RPM  
Drive Pulley—1/5 pitch, 15 tooth  
Timing Belt Pulley—U.S. Rubber Co. XL-025 recommended.

**TAPE TENSION AND FEED**

Maximum tension of tape supply should not exceed 6 oz.

**ELECTRICAL**

*Clutch Control Solenoid*  
2000 turns No. 33 single formvar.

55 OHMS plus-minus 10% at 70 degrees F.  
24 VDC plus-minus 10%. (Series impedance of 50 OHMS shunted by 50 microfarad capacitor.)

*Semi-automatic Tape Feed Solenoid*  
Phillips control type 42  
115 OHMS plus-minus 10% at 70 degrees F.  
24 VDC plus-minus 10%.

*Interfacing*  
Wiring terminates at two 12 pin connectors. Mating connectors and pins are supplied by manufacturer.

*Environmental*  
Operating temperature and humidity 55° to 100°F operating; 10° to 150°F non-operating.  
20% to 95% without condensation: operating  
5% to 95% without condensation: non-operating



**MODEL 268  
INTEGRATED  
READER STATION**

The Model 268 Integrated Reader Station provides a complete tape read facility. In this configuration, an 8 1/2" reel of punched tape is placed into the drawer mounted at the base of the unit. The tape feeds through the read head and a tape guide (located at the rear) to a side mounted take-up reel. Take-up reels in either 7 1/2" or 8 1/2" diameters are available. Overall dimensions are: 13 1/2" wide x 15" deep x 9 1/2" high. Weight is approximately 23 1/2" lbs.



**SERIES 200  
READER  
TIMING  
CHART**

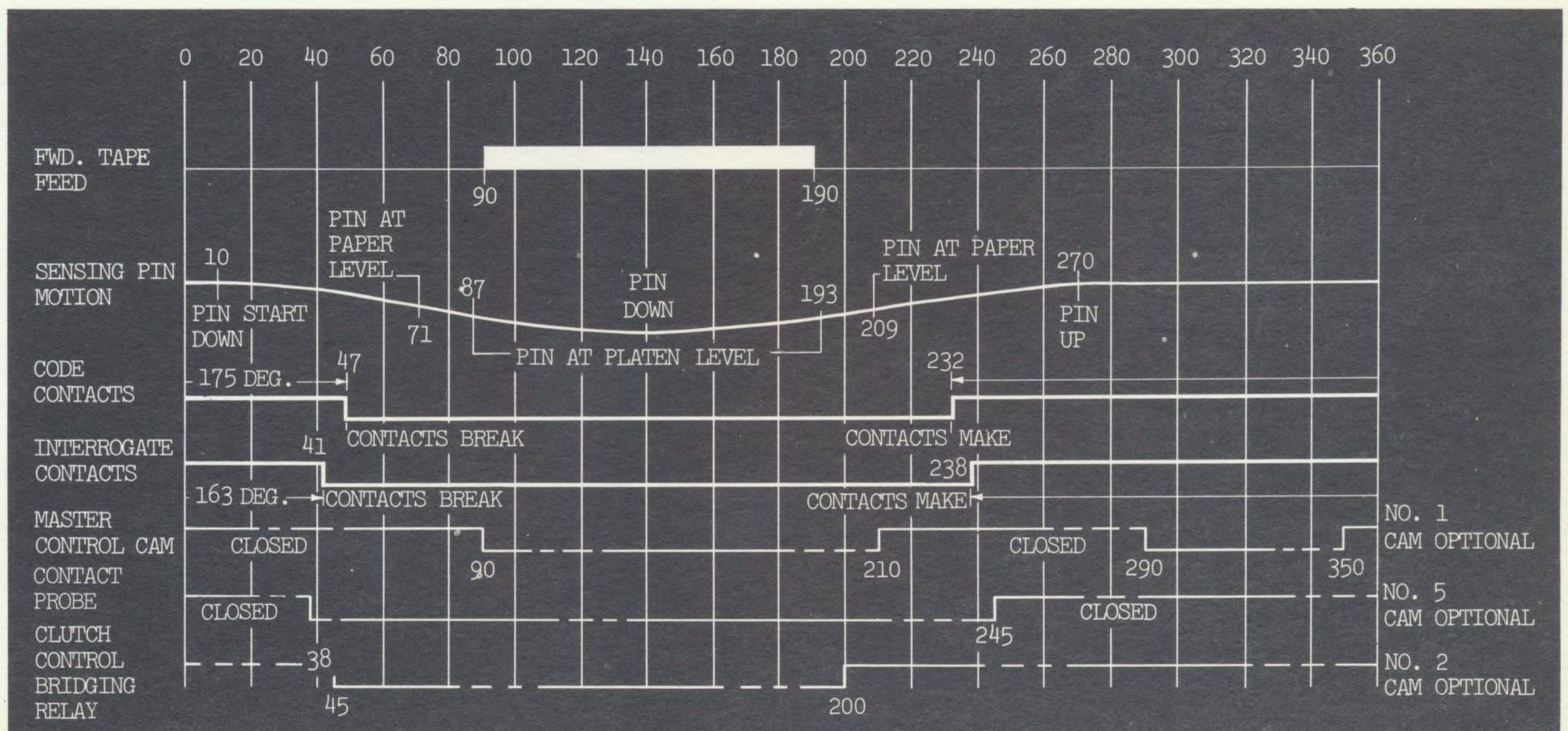



## ROYTRON COMBINATION READER/PUNCH UNITS

*Overall dimensions of Roytron reader/punch units are: 12<sup>3</sup>/<sub>8</sub>" long x 10<sup>7</sup>/<sub>8</sub>" wide x 6<sup>1</sup>/<sub>2</sub>" high. Weight is approximately 22 lbs. Optional features are: Out of tape switch; parity check (odd or even); manual tape feed control.*

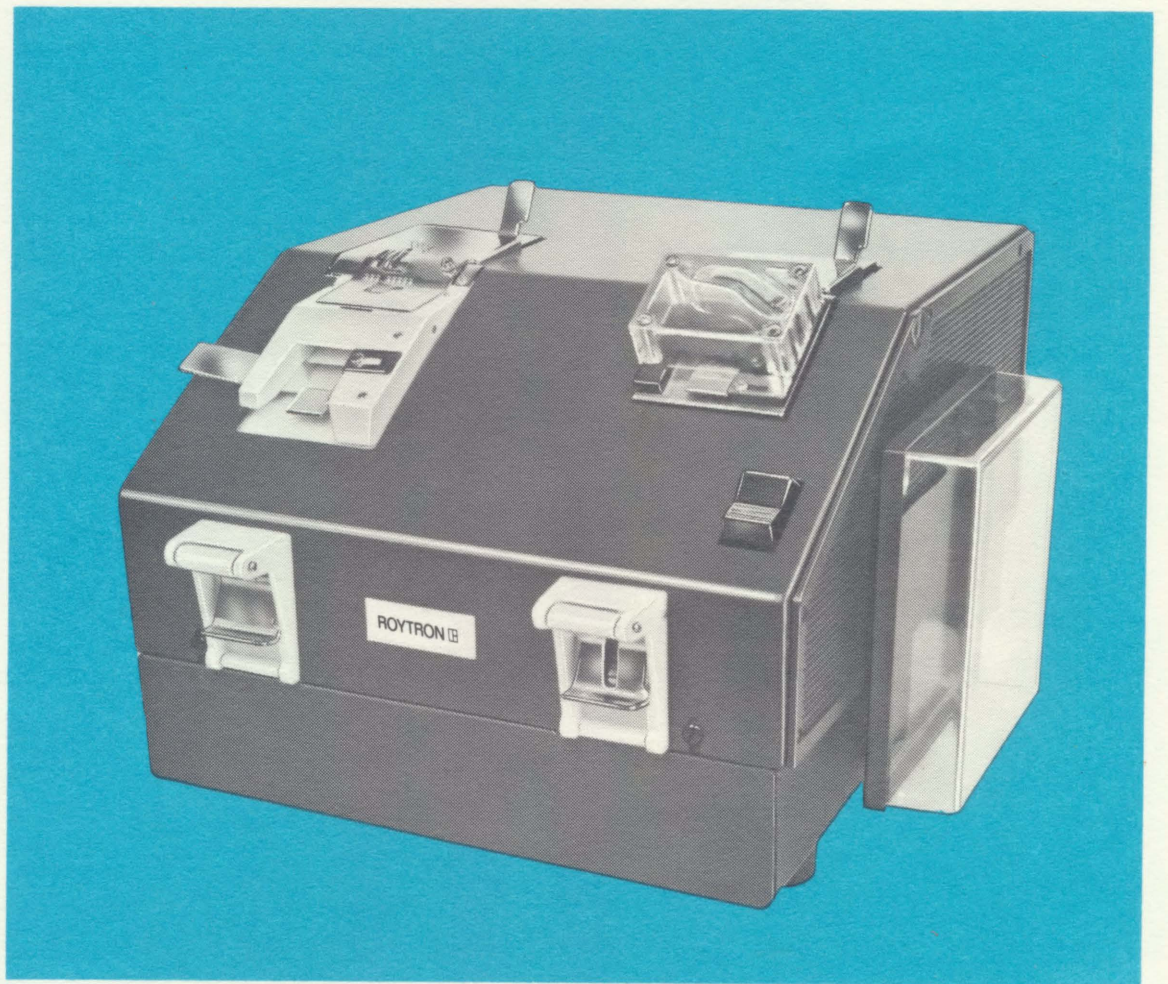

### **LEVEL 2 READER/PUNCH**

In this configuration, the basic reader and punch mechanisms share a common housing and motor drive, but are electrically independent. Standard features include tape tension switches and reverse feed on both reader and punch, tape feed switch on punch and semi-automatic tape loading on the reader. This is a complete punched tape facility for users who prefer to develop their own logic and circuitry. Interface identical to Level 2 punch and Level 2 reader.

### **ROYTRON SERIES 500**

Synchronous operation at 50 cps.  
Model 582—Standard reader/punch unit.  
Model 583—Incorporates features for handling six level advanced feed hole tape.

### **ROYTRON SERIES 700**

Synchronous operation at 75 cps.  
Model 782—Standard reader/punch unit.  
Model 783—Incorporates features for handling six level advanced feed hole tape.

### **LEVEL 3 READER/PUNCH**

All associated electronic logic modules have been included in this level of reader/punch units. Interface is identical to Level 3 punch and Level 3 reader.

### **ROYTRON SERIES 500**

Synchronous operation at 50 cps.  
Model 592—Standard reader/punch unit.  
Model 593—Incorporates features for handling six level advanced feed hole tape.

### **ROYTRON SERIES 700**

Synchronous operation at 75 cps.  
Model 792—Standard reader/punch unit.  
Model 793—Incorporates features for handling six level advanced feed hole tape.



## ROYTRON 500 PUNCHED TAPE VERIFY-DUPLICATE SYSTEM

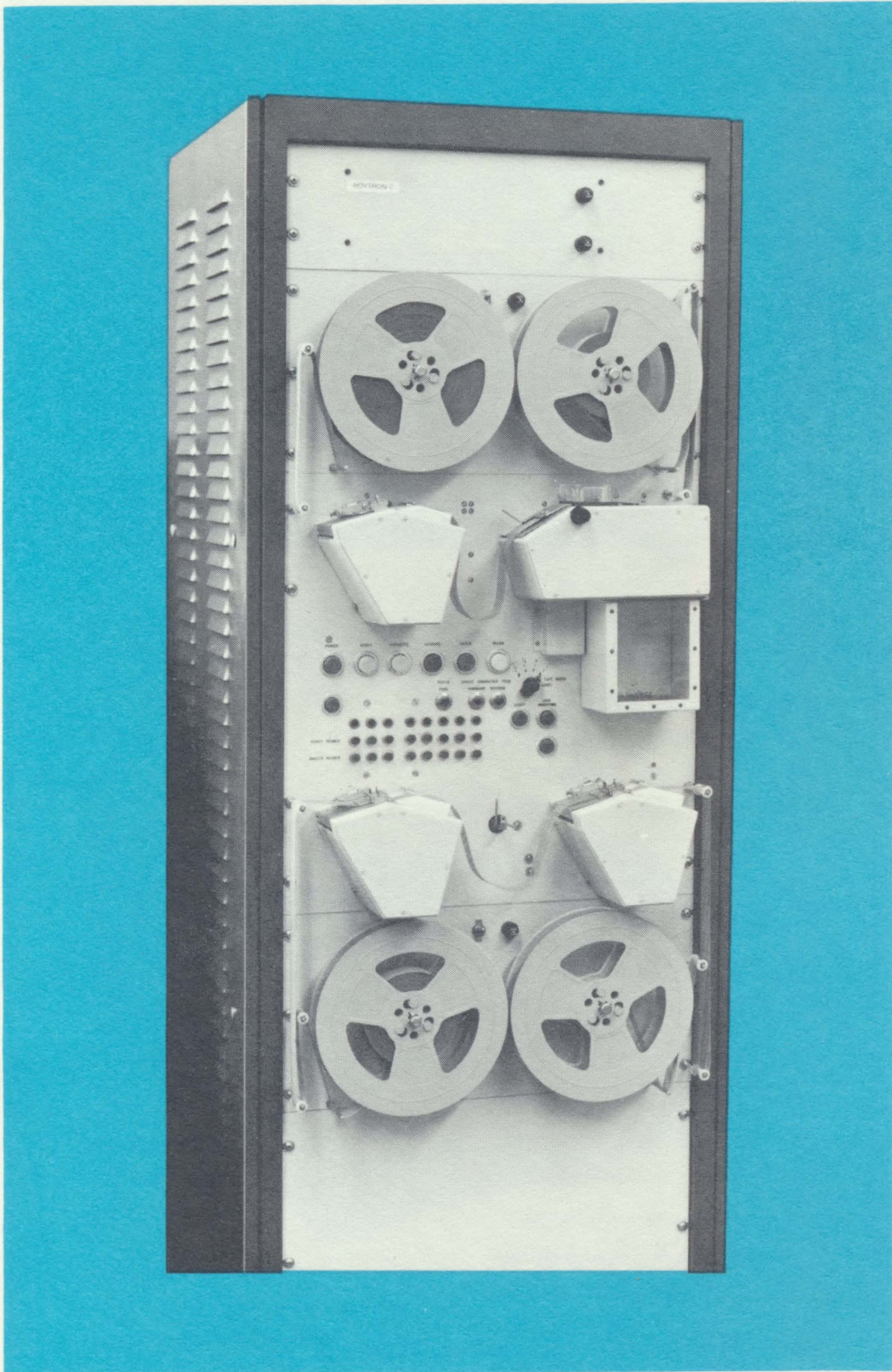

The Roytron 500 Verify-Duplicate System is a "one-pass" system for producing a verified duplicate punched paper or mylar tape. It utilizes three readers and one punch to perform all functions in one continuous cycle. A master tape, which can be spooled, looped or fan-folded, is read by two readers, the first of which activates the punch. The other master tape reader is synchronized with a third reader which scans the duplicate tape as it comes out of the punch.

A double row of lights indicates the bit configuration in both the Master Tape Verification Reader and the Duplicate Tape Verification Reader at the point of verification. If the two tapes do not match, the system will automatically stop, displaying the two non-matching code patterns. An error light also comes on. Single tape feed controls are provided for alignment of tapes and simplified error correction. An inch switch, incorporated into the unit to facilitate tape loading and error correction, advances the two tapes one character at a time.

The system operates at 50 characters per second and can be used for straight tape duplication, straight verification or simultaneous duplication and verification of five, six, seven or eight level paper or mylar tapes. Duplicated tapes are chad type, master tapes may be chad or chadless. Verified duplicates of master tape loops of up to 250 feet long can be continuously produced. Provisions for safeguarding the master and duplicate tapes during operation are included. Take up reels are provided for both master and duplicate tapes. Fan fold capabilities for both tapes are provided by detachable containers. Optional facilities for fan fold loop operation are available.

## OPTIONS

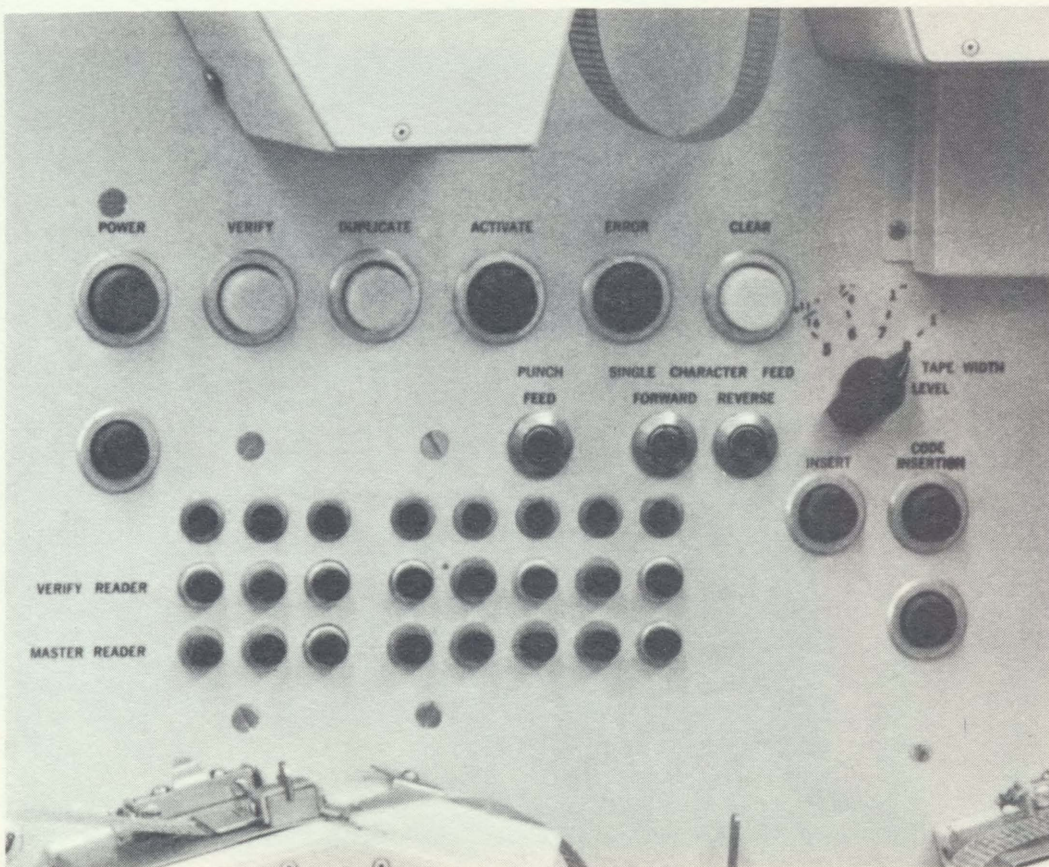

- Fan-fold capability for the master and duplicated tapes is provided through detachable containers.
- Code Insertion. When installed in the system, this option provides means for punching in the "Duplicate" tape individual bits or any desired new character not present in the master tape. The option is comprised of a series of eight switches, (one for each bit), a code insert mode and an insert switch.
- Null Inhibit. When the master reader reads a null at the 5, 6, 7 or 8 level, depending on the lever selector switch position, it prevents the punch from duplicating the null. When the two tapes are passed through the verify station, a compensation is made for the mismatching codes.



## ROYTRON TAPE SYSTEMS

## ROYTRON AUXILIARY EQUIPMENT

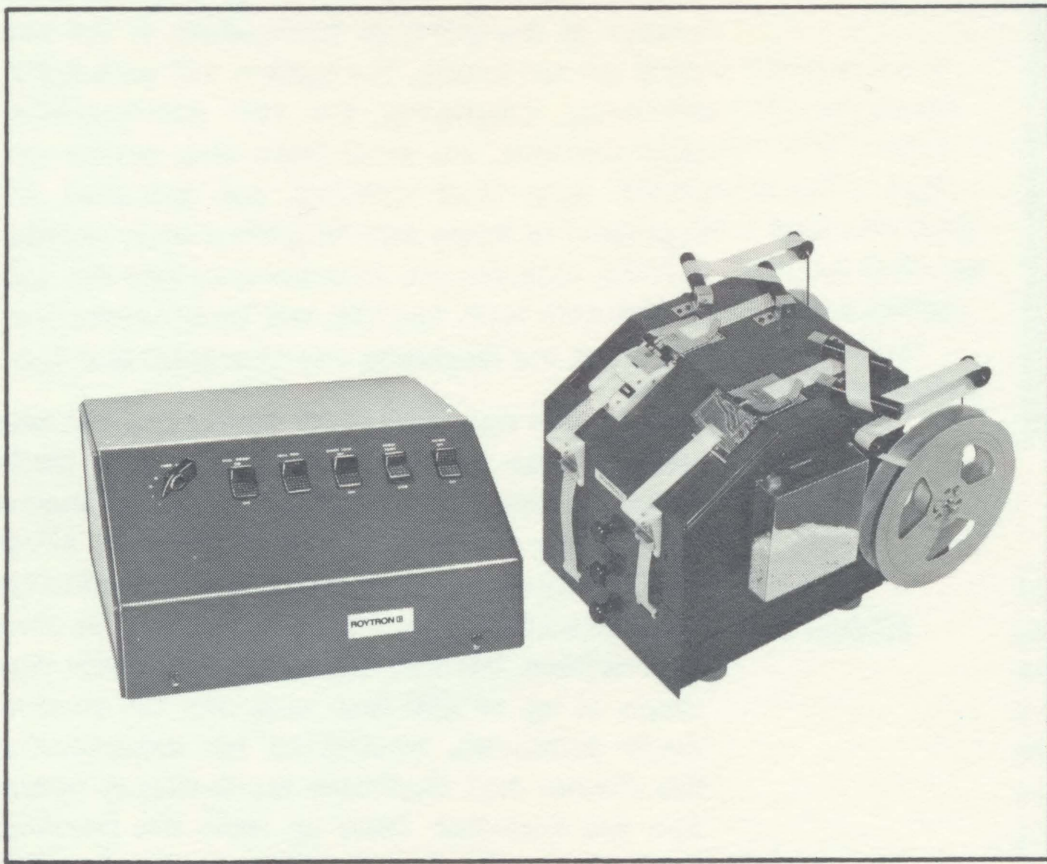

### ROYTRON 500 PUNCHED TAPE REGENERATOR

The Roytron Punched Tape Regenerator consists of a combination reader/punch station, cable-connected to a separately-housed logic, control and power unit (Model 535). It will duplicate punched tape continuously at 50 characters per second using a Model 592, and at 75 characters per second using a Model 792.

Standard features include: tape tension switches; reverse feed on both reader and punch; semi-automatic tape loading on the reader; optional regeneration of delete codes; regen lock and unlock; manual index control on punch; tape feed control to put blank or delete feeds between messages. Accommodates 1", 7/8" or 1 1/16" standard tapes with 5-, 6-, 7- or 8-level code. Tape supply drawers and tape take-up are incorporated for both the reader and the punch.

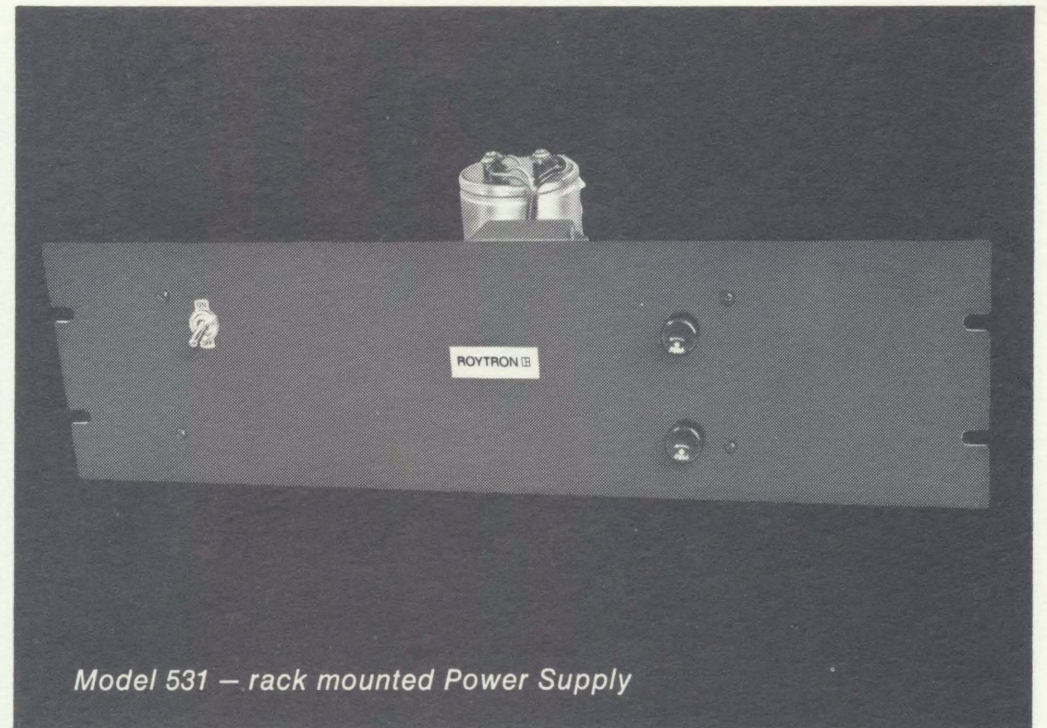

Model 531 — rack mounted Power Supply

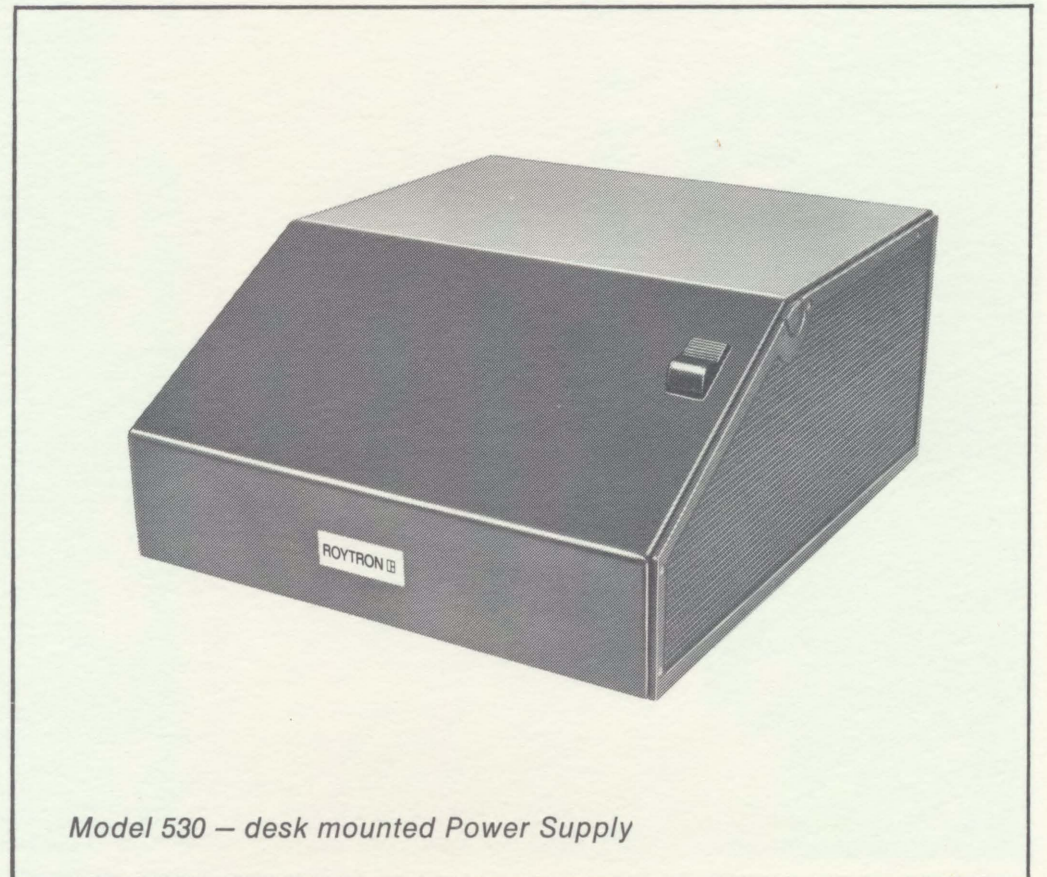

Model 530 — desk mounted Power Supply

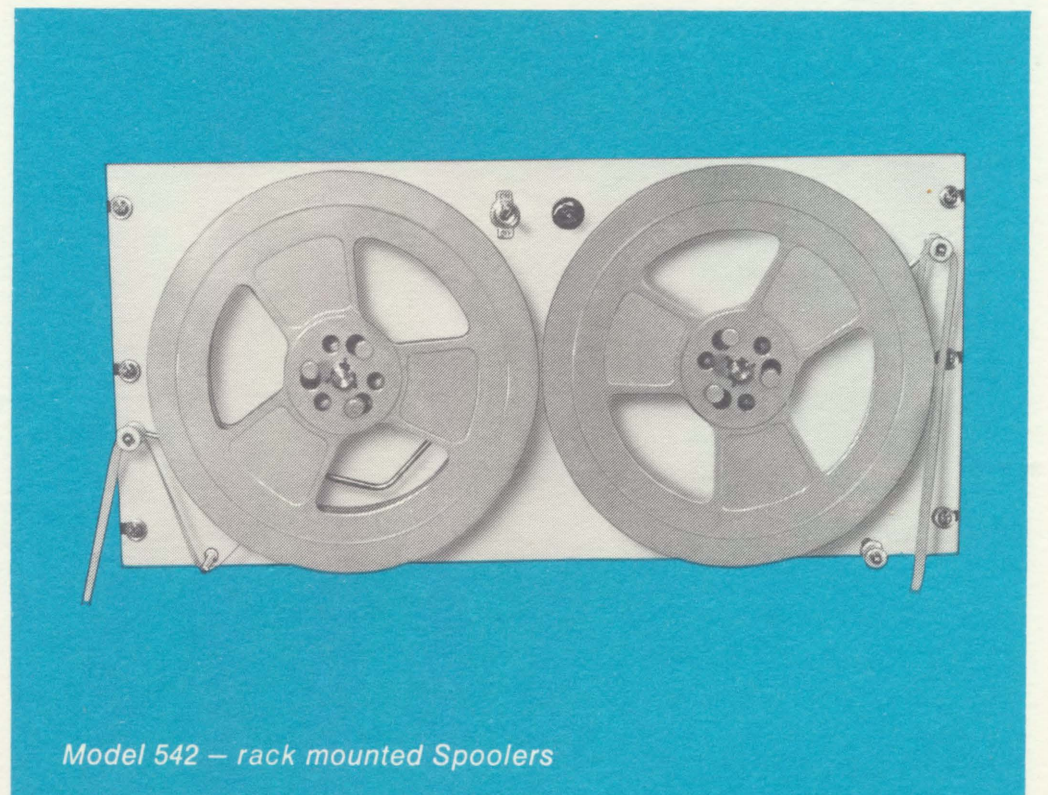

Model 542 — rack mounted Spoolers



## ROYTRON SALES OFFICES

### EASTERN AREA

Mr. Donald White  
Roytron Division  
780 N. River View Drive  
Totowa, New Jersey  
201 256-0174

### WESTERN AREA

Mr. Lloyd Mallory  
Roytron Division  
1931 S. Manchester Ave.  
Anaheim, California  
714 638-3220

## ROYTRON SALES REPRESENTATIVES

### EAST COAST

Brogan Associates  
69 Hickory Drive  
Waltham, Massachusetts  
617 894-3250

Brogan Associates  
780 N. River View Drive  
Totowa, New Jersey  
201 256-0174

Brogan Associates  
484 Thurston Road  
Rochester, New York  
716 328-0510

Brogan Associates  
202 Arterial Road  
Syracuse, New York  
315 437-2988

Brogan Associates  
80 Urban Avenue  
Westbury, L. I., N. Y.  
516 333-6683

Brogan Associates  
107 West Ridge Pike  
Conshohocken, Pa.  
215 825-0510

### SOUTHEAST

Reynolds & Associates  
904 Bob Wallace Avenue  
Huntsville, Alabama  
205 536-1941

Reynolds & Associates  
P.O. Box 1043  
Eau Gallie, Florida  
305 254-0520

Reynolds & Associates  
4677 N.W. First Street  
Ft. Lauderdale, Florida  
305 581-6611

Reynolds & Associates  
1010 Executive Drive Road  
Orlando, Florida  
305 841-4840

Reynolds & Associates  
P.O. Box 13088  
St. Petersburg, Florida  
813 345-2128

Reynolds & Associates  
P.O. Box 13173, Sta. K  
Atlanta, Georgia  
404 876-0652

H. J. Heffernan Company  
1123 North Irving Street  
Arlington, Virginia  
703 JA 2-6666

### MIDWEST

R. Edward Stemm, Inc.  
5681 West Lake Street  
Chicago, Illinois  
312 379-2700

Lloyd F. Murphy & Assoc.  
730 Chicago Avenue  
Minneapolis, Minnesota  
612 333-4511

Tower Engineering  
7016 Euclid Avenue  
Cleveland, Ohio  
216 881-3511

Tower Engineering  
2801 Far Hills Avenue  
Dayton, Ohio  
513 298-1491

### SOUTHWEST

Costello & Company  
3922 N. 30th Avenue  
Phoenix, Arizona  
602 266-4448

Costello & Company  
2090 W. Littleton Blvd.  
Littleton, Colorado  
303 798-8635

Costello & Company  
5635 Yale Blvd.  
Dallas, Texas  
214 EM 3-9031

Costello & Company  
4848 Guiton Street  
Houston, Texas  
713 665-5413

### WEST COAST

Costello & Company  
5795 West Washington Blvd.  
Culver City, California  
213 937-2980

Costello & Company  
535 Middlefield Road  
Palo Alto, California  
415 DA 1-3745

### CANADA

Datagraphics  
2239 Prescott Highway  
Ottawa, Ontario

### EUROPE

B.F.I. Electronics, Ltd.  
Sinclair House—The Avenue  
London W13, England

B.F.I.  
52 Avede New York  
Paris 16 eme, France

B.F.I. Elektronik Gmbh.  
Hainerweg 26/28  
6 Frankfurt/Main  
West Germany

**New York Office for  
B. Freudenberg, Inc.**  
B. Freudenberg, Inc.  
50 Rockefeller Plaza  
New York, N. Y.  
212 PL 2-9130

### FAR EAST

Kyokuto Boeki Kaisha, Ltd.  
7th Floor, New Otemachi Bldg.  
4 2-Chome, Otemachi, Chigada-Hu  
Tokyo, Japan

**New York Office for  
Kyokuto Boeki Kaisha**  
Far East Mercantile Corp.  
50 East 42nd St.  
New York, N. Y.  
212 MU 7-8564

## ROYTRON SERVICE CENTERS

### EAST COAST

Royal Typewriter Company, Inc.  
1700 Wisconsin Avenue, N.W.  
Washington, D. C.  
202 FE 7-8900

Royal Typewriter Company, Inc.  
1280 Soldiers Field Road  
Boston, Massachusetts  
617 782-7032

Royal Typewriter Company, Inc.  
386 Fulton Avenue  
Hempstead, New York  
516 IV 3-3800

Royal Typewriter Company, Inc.  
572 North Broadway  
White Plains, New York  
914 WH 9-0233

Royal Typewriter Company, Inc.  
3913 Chestnut Street  
Philadelphia, Pa.  
215 EV 2-7900

Royal Typewriter Company, Inc.  
913 Pennsylvania Avenue  
Pittsburgh, Pa.  
412 AT 1-9630

### SOUTHEAST

Royal Typewriter Company, Inc.  
1117 W. Peachtree Street, N.W.  
Atlanta, Georgia  
404 TR 3-2211

### MIDWEST

Royal Typewriter Company, Inc.  
530 N. Lake Shore Drive  
Chicago, Illinois  
312 SU 7-2020

### SOUTHWEST

Royal Typewriter Company, Inc.  
100 W. 11th Avenue  
Denver, Colorado  
303 244-9294

Royal Typewriter Company, Inc.  
2801 Maple Avenue  
Dallas, Texas  
214 RI 7-7531

### WEST COAST

Royal Typewriter Company, Inc.  
2828 Beverly Blvd.  
Los Angeles, California  
213 385-5201

Royal Typewriter Company, Inc.  
54 Tenth Street  
San Francisco, California  
415 MA 6-2757



# ROYTRON

ROYAL TYPEWRITER COMPANY, INC. A DIVISION OF LITTON INDUSTRIES

150 NEW PARK AVENUE, HARTFORD, CONN. 06106 PHONE (203) 233-2621

SALES OFFICES AND SERVICE CENTERS LOCATED IN ALL PRINCIPAL CITIES