

**SONY**

**SDK-5000/5200/M SERIES**  
**SDT-5000/5200/M SERIES**  
DDS TAPE DRIVE

OPERATION/MAINTENANCE  
MANUAL

## NOTICE

This document contains proprietary information which is protected by copyright. All rights reserved. No part of this document may be photocopied, reproduced or translated to another language without prior written consent of Sony. The information contained in this document is subject to change without notice.

SONY MAKES NO WARRANTY OF ANY KIND WITH REGARD TO THIS DOCUMENT. Sony shall not be liable for errors contained herein, or indirect, special, incidental or consequential damages in connection with the furnishing, performance, or use of this document.

Printed in USA

October 1994

© 1994 Sony Electronics Inc.

Business and Professional Products Group

Technical Publications, 3300 Zanker Road, San Jose, California 95134

## 1.0 INTRODUCTION

### Overview

The SDK-5000/5200/M and SDT-5000/5200/M series tape drives are Digital Data Storage (DDS) devices used for high-capacity data storage.

The drive can store up to 8 GB on a single 120m tape when data compression is used, and can read and write DDS and DDS-2 format tapes.

In addition, the built-in SCSI-2 interface allows the drive to be used with a broad range of computer platforms and software.

The unit has an average sustained transfer rate of 732 KB/second with compression enabled, and data reliability is achieved through the Read After Write (RAW) function and three distinct levels of Error Correction Code (ECC).

## Features

Major features of the unit include:

- 80,000 hour Mean Time Before Failure (MTBF) at 20% duty cycle
- Support for 60, 90 and 120 meter tape lengths
- 1MB data buffer
- Frame re-write function
- High speed search (200x normal read/write speed)
- Variable or fixed recording block length
- SCSI-2 sequential access command set
- Random read
- N-Group write (optional)
- Dual partition tape (optional)

## Introduction

### Models

There are two types of models available:

External versions:

**SDK-5000/M** – single-ended SCSI with data compression;

**SDK-5200/M** – single-ended SCSI without data compression.

Internal versions:

**SDT-5000/M** – single-ended SCSI 3.5" HH with data compression;

**SDT-5200/M** – single-ended SCSI 5.25" HH without data compression.

### Accessories

The following accessories are available:

- **Kit-5S1W-2** (SDT models only)  
5.25" bezel mounting kit, Sony gray
- **Kit-5S1B-2** (SDT models only)  
5.25" bezel mounting kit, black
- **Kit-5ATG-2** (SDT models only)  
Bezel mounting kit, platinum gray
- **DG5CLa**  
Cleaning tape, 120m

For accessory ordering information, contact your local Sony dealer at 1-800-352-7669.

## 2.0 INSTALLATION

### **Packing/Unpacking**

When initially unpacking the unit, be sure to save the packing materials in case it should become necessary to ship the drive to another destination.

Before shipment, make sure that there is not a tape in the drive before repacking the unit.

### **Hardware Requirements**

#### **SDK-5000/5200/M:**

- Power cable (supplied)
- External terminator (supplied)
- 50-pin Centronics male-to-male SCSI connector
- SCSI host adaptor

#### **SDT-5000/5200/M:**

- 50-pin SCSI ribbon cable
- SCSI host adaptor or embedded SCSI
- Power supply cable from external computer

### **Software Requirements**

DDS format tape drives are designed to operate with a wide variety of software applications on multiple platforms and operating systems.

For software compatibility information, contact Sony Technical Support at 1-800-326-9551.

### Environmental Considerations

The unit should be placed in an area such that it will not be exposed to direct sunlight, high temperature, high humidity or mechanical vibration.

Temperature limits (operating):

41°F to 104°F (5°C to 40°C), 35% RH

Storage temperature range

-40°F to 158°F (-40°C to 70°C)

Altitude range:

Zero to 7,000 feet

Suspended particulate (operating):

Less than 150 microgram/m<sup>3</sup>

Vibration (operating):

Swept sine 3 to 500Hz @ 0.25G peak,  
1 octave/min., 3 axis, 3 directions

Vibration (non-operating):

Swept sine 3 to 500Hz @ 0.5G peak,  
1 octave/min., 3 axis, 3 directions

Shock (operating):

No data loss,  
Half sine, 5G peak, 3ms,  
3 axis, 2 directions, 10 second interval

Shock (non-operating):

No damage,  
Half sine 90G peak, 3ms (30G peak, 11ms),  
3 axis, 2 directions, 10 second interval

Installation

**Dimensions**

The dimensions for SDT series units are shown in Figure 2-1.

SDK series dimensions are as follows:

- Width: 6.9"
- Height: 2.6"
- Depth: 9.6"

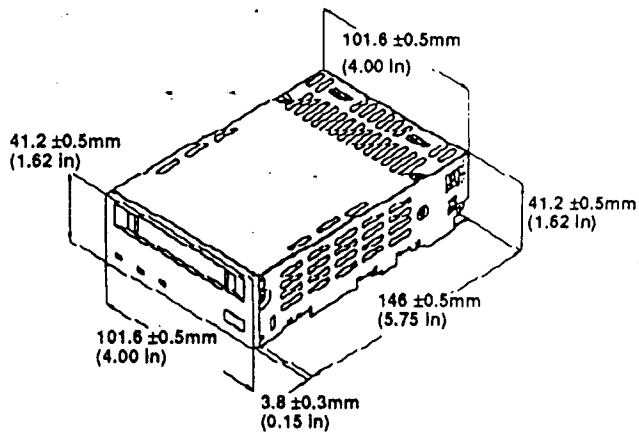

Figure 2-1. SDT Dimensions



### Mounting Hole Locations

The mounting holes for SDT series units are shown in Figure 2-2. Four mounting screws, size M3 (metric) are required.

**CAUTION:** To prevent damage to the drive, mounting screw thread length should not exceed 2.5mm.

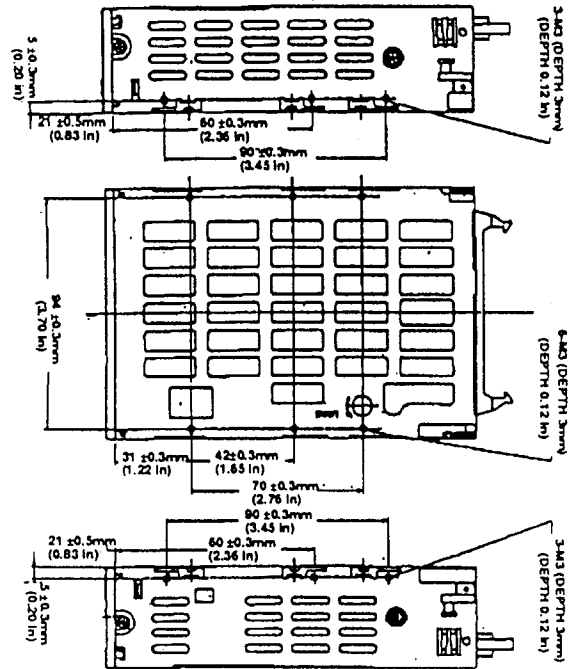

Figure 2-2. SDT Mounting Holes

*Installation*

**Orientation**

The SDT series can be installed in three different mounting positions, as shown in Figure 2-3. Each position has a maximum tolerance of  $\pm 10$  degrees.

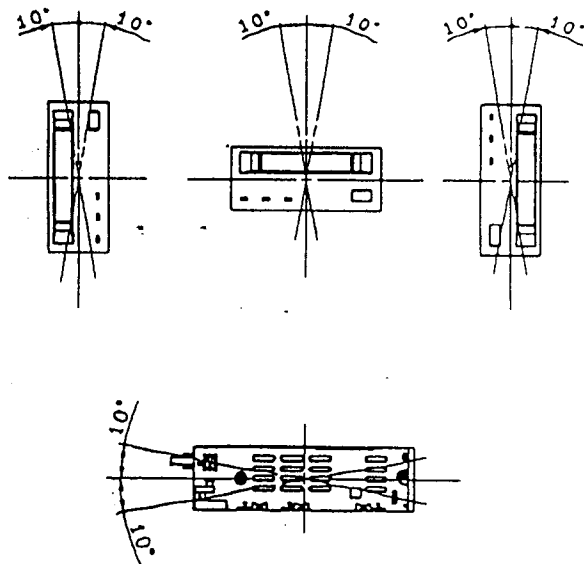

Figure 2-3. Drive Orientation

### External Connections

The power, jumper, and SCSI connections for SDK and SDT units are shown in Figures 2-4 and 2-5, respectively.

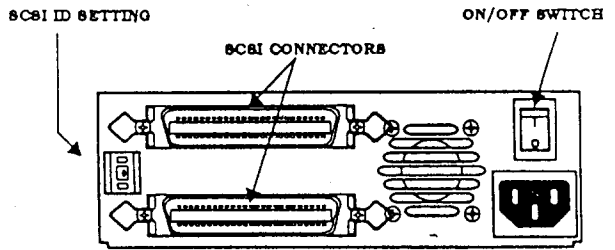

Figure 2-4. SDK External Connections

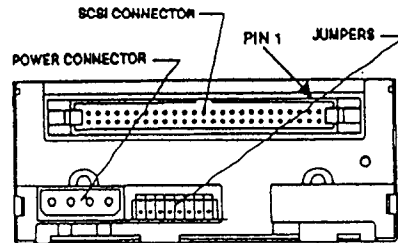

Figure 2-5. SDT External Connections

Installation

**Power Requirements**

**NOTE:** Never install or remove the power connector when the unit is powered on.

**SDK Series**

Power specifications for the SDK series are as follows:

40W @ 120VAC  
20W @ 220VAC

**SDT Series**

The power connector for SDT units is shown in Figure 2-6. Power specifications are as follows:

Voltage	Ripple (max)	Current	
		Typical	Max
5V $\pm$ 5%	100mV p-p	0.8A	1.4A
12V $\pm$ 5%	100mV p-p	0.2A	0.5A

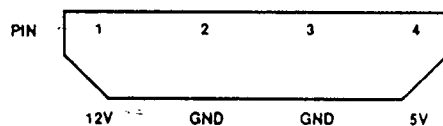

Figure 2-6. SDT Power Connector

### Jumper Configuration

The jumper configuration connector for SDT units is shown in Figure 2-7.

**NOTE:** Never install or remove jumpers when the unit is powered on.

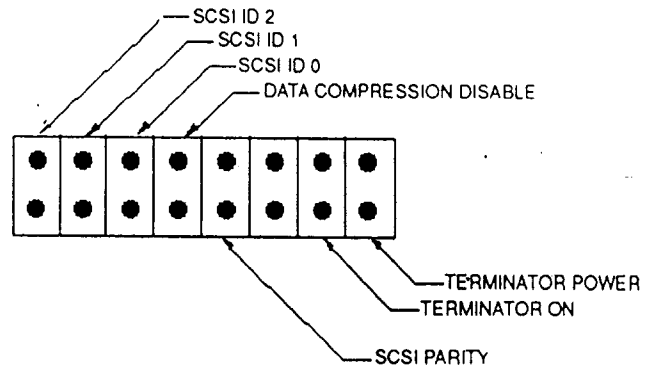

Figure 2-7. Jumper Configuration

### **Unloading a Tape**

A cassette may be unloaded in one of two ways: in response to a SCSI Unload Command, or by pressing the EJECT button located on the front of the unit.

Unload time for a single partition tape is less than 20 seconds after the command is issued or the key is pressed.

### **Write-protecting a Tape**

To write-protect a tape, slide the tab on the back of the cassette to the open position. In this way, data can be read but not written to the tape.

### **Using the Cleaning Tape**

Although the unit has a built-in head cleaner designed to last the life of the drive, a cleaning tape should be used periodically to clean the tape path.

Minimum recommended cleaning is at the LED request, which is displayed after every 24 hours of drum rotation (refer to page 3-3).

### Emergency Tape Removal

**CAUTION:** This procedure must be performed only by mechanically qualified personnel to avoid damage to the tape. Do not proceed if it appears the tape or drive will be damaged.

1. Refer to Figure 3-1. Remove the drive from the chassis or enclosure to allow access to the bottom and left side of the drive.
2. Remove the top cover to the drive.
3. Rotate the motor shaft by turning the UNLOAD/LOAD adjustment on the bottom of the drive clockwise until the threading mechanism is in its initial position.
4. Press the ratchet mechanism on the left side of the drive until all tape slack is completely removed.
5. Continue to rotate the motor shaft clockwise until the tape lifts out of the drive mechanism and ejects.

**NOTE:** If you feel a click in the turning mechanism, stop turning. This means you have reached the end of the mechanism's unload path. Turn in the opposite direction until the clicking stops.

6. Take the drive to your Sony Regional Service Center for repair, or call Sony Service at (408) 922-0699.

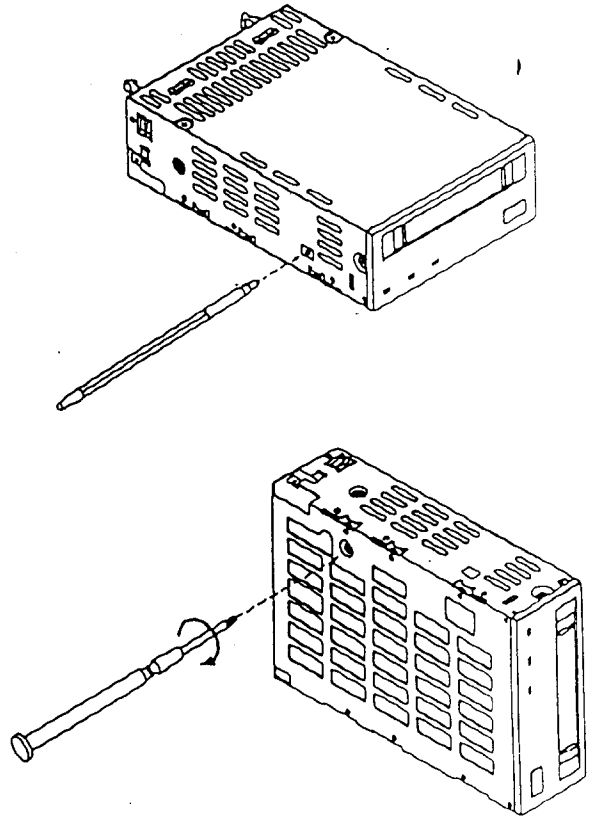

Figure 3-1. Emergency Tape Removal



*Operation*

### **SCSI Messages and Commands**

The following SCSI messages and commands are supported:

#### SCSI Messages:

- Abort
- Bus Drive Reset
- Command Complete
- Disconnect
- Extended Message
- Identify (with and without Disconnect)
- Initiator Detected Error
- Linked Command Complete
- Linked Command Complete (with Flag)
- Message Parity Error
- Message Reject
- No Operation
- Restore Pointers
- Save Data Pointer
- Synchronous Data Transfer Request

SCSI Commands:

Erase  
Extended Diagnostic  
Inquiry  
Load/Unload  
Locate  
Log Select  
Log Sense  
Mode Select (6)  
Mode Sense (6)  
Prevent Allow Medium Removal  
Read  
Read Block Limits  
Read Buffer  
Read Log  
Read Position  
Receive Diagnostic Results  
Recover Buffered Data  
Release Unit  
Request Sense  
Reserve Unit  
Rewind  
Seek Block  
Send Diagnostic  
Space  
Test Unit Ready  
Verify  
Write  
Write Buffer  
Write Filemarks

*Operation*

### **Read After Write Error Correction**

For Read After Write (RAW) error correction, each frame can be rewritten up to 127 times.

With N-Group writing, where every group is written a fixed number of times, the upper limit is 8.

**APPENDIX A SPECIFICATIONS****Specifications**

All specifications are typical at 25°C and subject to change without notice.

**Power requirements:**

5VDC, 12VDC ±5% (SDT-5000/M)

5VDC, 12VDC ±5% (SDT-5200/M)

120/220VAC (SDK-5000/M)

120/220VAC (SDK-52000/M)

**Power consumption:**

6.5 W (SDT-5000/5200/M)

40/20W (SDK-5000/5200/M)

**Linear recording density:**

61,000 BPI

**Access time:**

35 sec (max.)

**Drum rotation speed:**

4,000 RPM

**Uncorrectable error rate:**Less than  $10^{-15}$  bits**High burst transfer rate:**

3MB/sec asynchronous

5MB/sec synchronous

**Ambient noise (A = curved weight):**

No greater than 25dB (A)

**Streaming read/write noise:**

35dB (A)

**Inset/eject noise:**

60dB (A)

*Specifications*

**Electromagnetic interference (EMI):**

**Radiated, conducted:**

**FTZ/FCC class B,**

**VCCI-2 equivalent**

**ESD discharge voltage:**

**Less than 15kV, no operation failure**

**Less than 20kV, no drive damage**

**APPENDIX B TROUBLESHOOTING****CANNOT INSERT TAPE INTO DRIVE**

- Ensure there is not a tape already in the drive by pressing the EJECT button.  
If the power was turned off with a tape in the drive, the tape will rewind to the beginning when the power is turned back on.
- Power the unit off. Wait five seconds, then power the unit on. Observe the drive for normal power-up sequence. If the LEDs do not illuminate properly, check the power supply and the power cable connection.

**CANNOT EJECT TAPE FROM DRIVE**

- If the PREVENT ALLOW MEDIA REMOVAL SCSI command has been sent to the drive with the prevent bit set to one, the tape will remain in the drive even after an UNLOAD command, and the EJECT key will be disabled.  
To override this condition the host computer can either: send a PREVENT ALLOW MEDIA REMOVAL command with the prevent bit clear, or issue a SCSI bus reset command; or you can turn the power to the drive off and then back on.  
If you have changed the bezel of the drive, verify that it has been installed correctly.  
If the tape will still not eject, the drive must be returned to Sony for service.

### **NO RESPONSE TO SCSI COMMANDS**

If the drive powers up and loads/unloads tapes properly but will not respond to SCSI commands, check for the following.

- If a SCSI bus reset does not cause the drive to power-on reset:
  - ensure all of the cables and connectors are properly seated and undamaged;
  - ensure pin 1 of the SCSI cable is aligned with pin 1 of the SCSI connector.
  
- If a SCSI bus reset causes the drive to power-on reset, then the problem is with the SCSI bus addressing or termination. Proceed as follows:
  - ensure that the SCSI ID jumpers are properly configured (refer to page 2-9);
  - ensure that the SCSI devices at each end of the SCSI cable are terminated, and that no terminator plugs are installed on any other SCSI devices (refer to page 2-12).

### **Sony Technical Support**

Technical assistance is available toll free, by calling 1-800-326-9551.