

MATRIX PRINTERS

Models:

**2233/2235
5533/5535**

PREFACE

This document is the Standard Maintenance (STD) Manual for the 2233/2235 5533/5535 Dot Matrix Printers. It is organized in accordance with the approved STD outline established at the Field/Home Office Publications meetings conducted on September 14th and 15th, 1982. The scope of this manual reflects the type of maintenance philosophy selected for this product (swap unit, printed circuit assembly, chip level or any combination thereof).

The purpose of this manual is to provide the Wang-trained Customer Engineer (CE) with instructions to operate, troubleshoot and repair the 2233/2235 5533/5535. It will be updated on a regular schedule.

Fourth Edition (July 1984)

This reprint is the new converted number for 729-0859-B and incorporates document 729-0859-B1. The material in this document may only be used for the purpose stated in the Preface. Updates and/or changes to this document will be published as Publications Update Bulletins (PUB's) or subsequent editions.

This document is the property of Wang Laboratories, Inc. All information contained herein is considered company proprietary, and its use is restricted solely for the purpose of assisting the Wang-trained CE in servicing this Wang product. Reproduction of all or any part of this document is prohibited without the prior consent of Wang Laboratories, Inc.

© Copyright WANG Labs., Inc. 1981, 1983, 1984

CONTENTS

CHAPTER 1 - INTRODUCTION		PAGE
1.1	Introduction	
1.2	Related Documentation	1-1
1.3	Dot Matrix Printer Models (2233/2235 5533/5535)	1-1
1.4	Printer Configurations	1-1
1.5	Printer Checklist	1-1
1.6	Printer Specifications	1-3
1.6.1	Models 2333/2235	1-4
1.6.2	Models 5533/5535	1-4
		1-6
CHAPTER 2 THEORY OF OPERATION		
2.1	Introduction	
2.2.1	Z80A CPU PCB (210-7953B/210-7593-1B)	2-1
2.2.2	Address and Data Bus Lines	2-1
2.2.3	Printer Prime F/F	2-2
2.2.4	Data Strobe F/F	2-3
2.2.5	Home Sensor	2-3
2.2.6	Right Sensor	2-4
2.2.7	Column Strobe Control	2-4
2.2.8	Driver/PS Regulator PCB P/N (210-7594)	2-4
2.2.9	Print head Operation	2-4
2.2.10	Keyboard Input Register	2-6
2.2.11	Cover Open/Paper Out Register	2-7
2.3	Model 5533/5535 Dot Matrix Printers	2-7
2.3.1	Direct Memory Access	2-8
2.3.2	PIO CPU PCB P/N (210-7348)	2-8
2.3.3	Data Link PCB P/N (210-7446)	2-8
2.3.4	RAM Memory PCB P/N (210-7547), (210-7847-A)	2-8
2.3.5	Select Switch	2-9
		2-9
CHAPTER 3 OPERATION		
3.1	Introduction	
3.2	Model 2233/2235 Controls and Indicators	3-1
3.2.1	ON/OFF Switch and Power Indicator	3-1
3.2.2	Select Switch and Select Indicator	3-1
3.2.3	Line Feed Switch	3-1
3.2.4	Top of Form Switch	3-2
3.2.5	Form Override Switch and Paper Out Indicator	3-2
3.2.6	Clear Switch and Indicator	3-2
3.2.7	Servo Fuse Indicator	3-2
3.3	MODEL 5533/5535 Controls and Indicators	3-4
3.3.1	ON/OFF Switch and Power Indicator	3-4
3.3.2	Select Switch and Select Indicator	3-4
3.3.3	Top Of Form Switch	3-4
3.3.4	Change Paper Indicator	3-5
3.3.5	Malfunction Indicator	3-5
3.3.7	Servo Fuse Indicator	3-5
		3-6

	PAGE
3.4 Cover Open Switch	3-6
3.5 Paper Loading	3-6
3.6 Ribbon Cartridge Replacement (All Models)	3-7
3.7 Print Adjustment	3-9
3.8 Operating Characteristics	3-10

CHAPTER 4 INSTALLATION

4.1 Introduction	4-1
4.2 Unpacking Packing and Inspection	4-1
4.2.1 Unpacking	4-1
4.2.2 Packing	4-3
4.3 Initial Printer Checks and Adjustments	4-3
4.4 Printer Power-On Procedure	4-12
4.5 Printer Self-Test	4-12
4.5.1 Power-Up Diagnostic Error Indicators	4-13
4.6 Switch Selected Print Quality Tests	4-14
4.7 2233/2235 Printer Diagnostics (2200 Systems)	4-21
4.7.1 Diagnostic Load Procedure	4-21
4.7.2 Operating Instructions	4-21
4.8 Printer Diagnostics Model 5533/5535	4-24
4.8.1 Load Procedure	4-24
4.9 Miscellaneous	4-26
4.10 Printer Signal Cables	4-26
4.11 Power Source 115/230 VAC Conversion	4-26
4.12 Paper Rack Installation	4-27

CHAPTER 5 PREVENTIVE AND CORRECTIVE MAINTENANCE

5.1 Introduction	5-1
5.2. Tools and Test Equipment	5-1
5.3 Checks and Adjustments	5-1
5.3.1 Print Head Retraction lever Check	5-1
5.3.2 Print Head Retraction Lever Adjustment	5-3
5.3.3 Matrix Print Head To Striker Bar Clearance Check	5-3
5.3.4 Matrix Print Head To Striker Bar Adjustment	5-3
5.3.5 Ribbon Guide Shield Adjustment and Carriage Notch Check	5-4
5.3.6 Striker Bar To Paper Guide Clearance Check	5-6
5.3.7 Striker Bar To Paper Guide Clearance Adjustment	5-6
5.3.8 Paper Drive Belt Tension Check	5-7
5.3.9 Paper Drive Belt Adjustment	5-7
5.3.10 Carriage Belt Tension Check	5-8
5.3.11 Carriage Belt Tension Adjustment	5-8
5.3.12 Left Hand Margin Sensor Check	5-8
5.3.13 Left Hand Sensor Margin Alignment	5-10
5.3.14 Right Sensor Check	5-10
5.3.15 Encoder Disk Check	5-12
5.3.16 Encoder Disk Alignment	5-12

	PAGE	
5.3.17	Power Supply Voltage Check	5-16
5.3.18	Speed Check and Adjustments	5-16
5.3.19	Right Sensor Check	5-18
5.3.20	Right Carriage Limit Sensor Adjustment	5-18
5.3.21	Paper Tension Spring Check	5-19
5.3.22	Paper Tension Spring Adjustments	5-19
5.4	Removal and Replacement	5-21
5.4.1	Motherboard P/N (210-7595), (210-7595-1)	5-21
5.4.2	Print Head Flex Cable P/N (220-3142)	5-23
5.4.3	Keyboard Cable P/N (220-3141)	5-23
5.4.4	Margin Sensor Cable Harness P/N (220-3184)	5-25
5.4.5	Power Supply Assembly P/N (270-0690)	5-25
5.4.6	Keyboard R & R P/N (271-1223), (271-1224)	5-28
5.4.7	Print Head Carriage Drive Motor P/N (279-5233-15)	5-28
5.4.8	Print Head Carriage Assembly Removal P/N (279-5233-19)	5-31
5.4.9	Print Head Carriage Assembly Replacement P/N (279-5233-19)	5-31
5.4.10	Paper Feed Motor P/N (279-5233-37)	5-33
5.4.11	End Cap P/N (449-0404)	5-33
5.4.12	Vernier Cone P/N (449-0405) Vernier Pulley P/N (449-0406)	5-33
5.4.13	Wire Rope Assembly P/N (600-9106)	5-35
5.4.14	Print Head P/N (725-0096)	5-35
5.4.15	Paper-Feed Tractor Removal P/N (725-1212), (725-1213)	5-35
5.4.16	Paper-Feed Tractor Replacement P/N (725-1212), (725-1213)	5-37
5.4.17	Front Carriage Shaft Lubrication	5-37
CHAPTER 6	SCHEMATICS	
6.1	Introduction	6-1
CHAPTER 7	ILLUSTRATED PARTS BREAKDOWN	
7.1	Introduction	7-1
CHAPTER 8	TROUBLESHOOTING	
8.1	Introduction	8-1
Appendix A	Paper Specifications	A-1
Appendix B	Module Test Descriptions	B-1
Appendix C	Printer Control Codes Models 2233/2235	C-1
Appendix D	Interconnect Diagrams	D-1

FIGURES

NO.	TITLE	PAGE
2-1	Printer Block Diagram	2-5
2-2	Serial Data Link (Models 5533/5535)	2-10
3-1	Controls and Indicators	3-3
3-2	Ribbon Cartridge Removal	3-8
4-1	Packing/Unpacking	4-2
4-2	Top Cover Removal	4-4
4-3	Voltage Selector Plug	4-5
4-4	J1 Installation PI/O CPU PCB P/N (210-7953B), (-1B)	4-8
4-5	Speed Control Jumpers (J1 and J2) PWR/Driver PCB P/N (210-7954)	4-9
4-6	PI/O CPU PCB P/N (210-7348)	4-10
4-7	Data Link PCB Switch and Jumper Settings	4-11
4-8	Test Switch and Error Indicators	4-15
4-9	Five Line Test	4-17
4-10	Spiral Pattern Test	4-18
4-11	Staircase Pattern Test	4-19
4-12	Vertical Bar Test	4-20
5-1	Print Head Retraction Lever	5-2
5-2	Print Head To Striker Bar Clearance	5-4
5-3	Ribbon Guide Shield Adjustment	5-5
5-3A	Carriage Notch	5-5
5-4	Striker Bar To Paper Guide Clearance Check	5-6
5-5	Paper Drive Belt Tension	5-7
5-6	Carriage Belt Tension	5-9
5-7	Left and Right Sensor Settings	5-11
5-8	Encoder Disk Removal	5-13
5-9	Encoder Disk	5-14
5-10	Power Supply Test Points	5-17
5-11	Paper Tension Spring Check	5-20
5-12	Motherboard Removal	5-22
5-13	Print Head Flex Cable	5-24
5-14	Margin Sensor Cable Harness	5-26
5-15	Power Supply Removal	5-27
5-16	Keyboard Model 2233/2235 P/N (271-1223)	5-29
5-17	Keyboard Model 5533/5535 P/N (271-1224)	5-29
5-18	Print Head Carriage Drive Motor	5-30
5-19	Print Head Carriage Assembly	5-32
5-20	Top and Bottom Pulley Diagram	5-34
5-21	Paper Feed Tractor	5-36
5-22	Carriage Shaft Lubrication	5-38

TABLES

TABLE	TITLE	PAGE
1-1	Printer PCB and Jumper Configuration	1-2
1-2	Printer Speeds	3-10
2-2	Pitch Selection	3-10
4-1	2233/2235 Power-Up Indicators	4-13
4-2	5533/5535 Power-Up Indicators	4-13
4-3	Print Quality Print Summary	4-14
8-1	Troubleshooting Chart	8-1

CHAPTER

1

**INTRO-
DUCTION**

CHAPTER 1 INTRODUCTION

1.1 SCOPE

This manual provides procedures necessary to pack, unpack, install and maintain Dot Matrix Printer Models 2233/2235 5533/5535. A detailed summary of printer configurations and a block-level theory discussion is provided. Error codes associated with power-up testing allow for fault isolation to the component level.

1.2 RELATED DOCUMENTATION

The following documentation is available for more detail regarding the 2233/2235 5533/5535 Dot Matrix Printers.

Document	Reorder Number
Model 2233 Printer User Manual	700-6854
Model 2235 Printer User Manual	700-6816
Model 5533/5535 Bidirectional User Manual	700-6954A

1.3 DOT MATRIX PRINTER MODELS (2233/2235 5533/5535)

The 2233/5533 2235/5535 Dot Matrix Printers are bidirectional printers intended for use on OIS, VS and 2200 Systems. The 2233/2235 printers accept 8 bit parallel data input and are intended for use of 2200 Systems. The 2233 is a slower version of the 2235. These printers print the ASCII 96 character set.

The 5533/5535 printers accept serial binary data input and are intended for use on WP, OIS and VS Systems. These serial printers print the 96 ASCII character set and 39 special characters for a total of 113 characters. The 5533 is marketed as 12 pitch serial printer that may be set for 10 pitch via the forms control utility in data processing mode on VS Systems. The 5535 is marketed as a 10 pitch serial printer and may be enabled for 12 pitch via the forms control utility in data processing mode on VS Systems.

All printers are capable of utilizing two impact dot matrices. For detail regarding switch setting and jumper configurations refer to Paragraph 1.4, Printer Configurations.

1.4 PRINTER CONFIGURATIONS

Hardware changes on the CPU and Pwr Driver PCB permit the speed of the printer and the print format to be changed by adding or removing jumpers on the two boards. With jumpers installed, the printer is wired for the higher print rate. With jumpers removed, the printer will print at the slower rate. Refer to Table 1-1 for more detail.

NOTE: E-REV compatibility must be observed with these hardware changes. A Pwr Driver PCB P/N (210-7594) with an E-Rev of 9 or higher must be used with a CPU PCB P/N (210-7593B/-1B) having an E-Rev of 7 or higher.

Table 1-1
Printer PCB and Jumper Configurations

Pwr Driver PCB (P/N 210-7594)	JPl/JP2	CPU	JP1	Power-Up Default	
2233	YES	OUT	210-7593B or 210-8393B	OUT OUT	12(P) Pitch*
2235	YES	IN	210-7593B or 210-8393B	IN IN	10 or 12P depending on (SW 5)
2233A	YES	OUT	210-8393R	OUT	12P*
2235A	YES	IN	210-8393R	IN	10 or 12P depending on (SW 5)
2233R	YES	OUT	210-7593B or 210-8393B	OUT OUT	12P*
2235R	YES	IN	210-7593B or 210-8393B	IN IN	10 or 12P depending on (SW 5)
5533	YES	OUT	210-7593-1B or 210-8393-1B	OUT OUT	12P**
5535	YES	IN	210-7593-1B or 210-8393-1B	IN IN	10P SW 5 OFF***
5533-1	YES	OUT	210-7593-1B or 210-8393-1B	OUT OUT	12P**
5535-1	YES	IN	210-7593-1B or 210-8393-1B	IN IN	10P SW 5 OFF***

* If 10 pitch power-up default is required install JP1. When JP1 (CPU Board) is installed SW 5 on the keyboard becomes active (on). With SW 5 on, 10 pitch (default) is enabled. With SW 5 off, 12 pitch (default) is enabled. With only this jumper installed, the speed test does not function correctly. JP 1 must be removed to perform speed adj. test and then reinstalled to allow the printer to default to 10 pitch.

** These printers are marketed as 12 pitch printers. Twelve pitch is a default value. To enable 10 pitch, the VS System must support data processing mode and forms control utility. If JP1 on the CPU Board is installed the printer may be enabled to default to 10 pitch on power-up by making SW 5 on the keyboard active (on). With SW 5 off, 12 pitch (default) is enabled.

***These printers are marketed as 10 pitch printers only. Ten pitch is a default value. To enable 12 pitch, the VS System must support data processing mode and forms control utility. If JP1 on the CPU Board is installed the printer may be enabled to default to 12 pitch on power-up by making SW 5 on the keyboard active (on). With SW 5 on, 10 pitch (default) is enabled. With SW 5 off, 12 pitch (default) is enabled.

Pwr/Driver PCB Jumper (J1 and J2) Installation

When installed, (JP1 and JP2) on the Pwr/Driver Board, the printer is configured to operate as the higher speed xx35 version. When not installed the printer is configured to operate as the lower speed xx33 version .

1.5 PRINTER CHECKLIST

22xxA Printers

The 22xxA class of printers default to 51 lines per page.

22xxR Printers

The 22xxR class of printers are intended for use on VS remote systems.

55xx-1 Printers

The 55xx-1 class of printers are 64K RAM based printers intended for use on Alliance based Systems.

2200 Printer Control Codes

2200 Printer control is completely programmable via an extensive selection of control codes. An electronic Direct Access Vertical Format Unit (DAVFU) can be loaded under program control to establish the vertical format. Other codes permit the following functions: (1) highlighted printing, expanded print (2) line feed, (3) carriage return, (4) form feed and (5) pitch selection. Refer to Appendix B for more detail regarding printer control codes.

1.6 SPECIFICATIONS

1.6.1 Model 2233/2235 Specifications

Printer Size

Height9.5 in. (24.2 cm.)
Height (with stand)....36.8 in. (93.5 cm.)
Width.....27.0 in. (68.6 cm.)
Depth.....20.9 in. (53.0 cm.)
Depth with stand.....27.0 in. (68.6 cm.)

Approximate Net Weight

68.0 lb (30.8 kg)

Printer Speed (characters per second-cps)

2233

120 cps (12.2 pitch)
100 cps (10 pitch)

2235

220 cps at (12.2 pitch)
180 cps at (10 pitch)

Character Configuration

7 by 9 dot matrix (12.2-pitch)
9 by 9 dot matrix (10-pitch)

10 or 12.2 characters per inch (4 or 4.9 characters per centimeter)
horizontally.

6 or 8 lines per inch (2.4 or 3.2 lines per centimeter) vertically.
(Programmable, standard is 6 lines per inch)

Character Set

Full ASCII 96 characters, both uppercase and lowercase.

Line Width

132 characters per line (10-pitch) (2235)
158 characters per line (12.2 pitch) (2233/2235)

Ribbon

Cartridge ink ribbon, recirculating

Programmable Control Functions (Appendix B)

Audio Alarm, Line Feed, Form Feed, Vertical Tab, Underscore, Expanded Print, Top of form, Carriage Return, Clear Buffer, Delete, Select Pitch, Load VFU, VFU Channel Skip, Skip Lines, Select Vertical Line Density, Select Font, Superscript and Subscript Printing.

Power Requirements

115 or 230 Vac \pm 10%
60 or 50 Hz \pm 1 Hz
1.10/0.55A, 126 watts

Fuses

3.0 amp (SB) for 115 Vac
1.5 amp (SB) for 230 Vac
2.5 amp (SB) for dc carriage motor

Cables

12 ft. (3.66m) cable with connector to CPU (Max Length from CPU=50')
6-ft (2.4m) cable to power source

Operating Environment

50 Deg.F to 80 Deg.F (10 Deg. C to 27 Deg C)
35% to 65% relative humidity, noncondensing

1.6.2 Model 5533/5535 Specifications

Printer Size

Height.....9.5 in. (24.1 cm)
Width.....26.4 in. (67.1 cm)
Depth.....20.8 in. (52.8 cm)
Depth with stand.....27.0 in. (68.6 cm)

Approximate Net Weight

68.0 lb (30.6 kg)

Printer Speed

Model 5533--120 characters per second at 12.2 pitch
Model 5535--180 characters per second at 10 pitch

Character Configuration

Model 5533--(7 by 9 dot matrix)
12.2 characters per inch (4.8 characters/cm) horizontally
6 lines per inch (2.4 lines/cm) vertically

Model 5535--9 x 9 dot matrix
10 characters per inch (4 characters/cm) horizontally
6 lines per inch (2.4 lines/cm) vertically

Character Set

113-character set
39 special characters

Line Width

132 characters Model 5535 (10 pitch)
158 characters Model 5533 (12.2 pitch)

Ribbon

Cartridge ink ribbon, recirculating

Power Requirements

115/230 Vac \pm 10%
60/50 Hz \pm 1 Hz
2.66A, 306 Watts

Fuses

3.0 amp (SB) for 115 Vac
1.5 amp (SB) for 230 Vac
2.5 amp (SB) for dc carriage motor

Cable

25.0 ft (7.6m) cable to Master CPU
6.0 ft (1.8m) cable to power source

Operating Environment

50 Deg. to 90 deg. F (10 deg.C to 32 deg. C)
35% to 65% relative humidity, noncondensing

Paper Specifications (All Models)

Maximum width14.9 in. (37.8cm)
Minimum width.....3.5 in. (8.9cm)
Maximum number.....Five copies plus original

Paper Stock

Material: Margin-perforated fan-fold card or paper stock
Single-part forms: 15 to 20-lb bond

Multipart forms:

2-ply.....15/15-lb bond, 7-lb carbon
3-ply.....15/12/15-lb bond, 7-lb carbon
4-ply.....12/12/12/15-lb bond, 7-lb carbon
5-ply.....12/12/12/12/15-lb bond, 5-lb carbon
6-ply.....12/12/12/12/12/15-lb bond, 5-lb carbon

CHAPTER

2

THEORY

OF

OPERA-

TIONS

CHAPTER 2 THEORY OF OPERATION

2.1 INTRODUCTION

The following paragraphs provide a block-level description that applies to the 2233/2235 5533/5535 Dot Matrix Printers. The block-level description in Paragraph (2.3), applies to the 5533/5535 Dot Matrix Printers only.

- Z80 CPU PCB P/N (210-7593-B), (210-7593-1B)
- Address and Data Bus lines
- Printer Prime F/F
- Data Strobe F/F
- Home Sensor
- Column Strobe Control
- Print Head Operation
- Driver/PS Regulator PCB P/N (210-7594)
- Keyboard Input register
- Cover Open/Paper Out Register

2.2.1 Z80A CPU PCB 7593-B/210-7593-1B

The Z80A CPU (L47) is the heart of the Dot Matrix Printers. The Z80 inputs and transfers host system data for processing, provides timing, and controls programming of the Programmable Input/Output device (PI/O) (L49). The Z80 CPU is clocked from a 3 MHz clock which is derived from a divide-by-2 circuit driven by a crystal oscillator at 6 MHz.

Port A of the PI/O receives command codes, operating codes, and system data from the host once printer power-up diagnostics have been completed.. Port B is an 8-bit bidirectional bus which is used for control information between the PI/O and printer. Both channels are accessed by the Z80 CPU software. No interrupts are used except for the column strobes.

2.2.2 Address and Data Bus Lines

Address lines A0 and A1 control programming of the PI/O. Address Lines A0, A1 and A2; and control lines "Write", "Read" and "I/O Request" (IORQ); are used by IN/OUT decoders (L23, L24) to select one of sixteen input/output lines. The decoded address lines enable printing and printer status to be monitored by the host system via the Load Status Register, enables error codes to be displayed on the printer front panel via the Error Display Register and enables input to the Status In Register. The command codes issued by the Z80 CPU to control printer operation may be referenced from Decoder chips (L23, L24). The following examples illustrate the code necessary to initiate a print operation and the code necessary to set the Status In Register and enable diagnostic switch settings.

To print a full line of characters, a Carriage return plus a line feed is needed and the paper feed motor needs stepping. Each OUT 05 steps the paper 1/48 of an inch. The I/O code to perform this operation is an OUT 05 (INC PAPER STEP). An OUT 05 is decoded as (A0 = bit 1) (A1=bit 2) and (A2 = bit 4). Both A0 and A4 are set to 1. The WRITE bit is set to 1, as a write operation is an output request. Every printer function requires an I/O request (IORQ set to 1).

Address Lines						
A0	A1	A2	WRITE	READ	IORQ	OUTPUT
1	0	1	1	0	1	OUT 05

The Status In Register is enabled by a STATUS IN COMMAND (IN 07), and is used as an input to self-test switches (5 position dip switch on the front panel) as shown by the following example:

Address Lines						
A0	A1	A2	WRITE	READ	IORQ	OUTPUT
1	1	1	0	1	1	IN 07

The switch setting information is placed on the data bus to be processed by the Z80 CPU. The results of the test sequence can be monitored from the front control panel.

Data on address lines A0-A10 are applied to Address Decoders via the Z80-A CPU Address Bus to select PROM (L42-L45) and RAM chips (L21 and L22). The four 2K PROM chips contain diagnostic code, printer control codes and code to enable pitch selection.

1K RAM is used for character code (for the print line), control code, DAVFU, and the pin buffer (decoded from the hex code received from the host system). 1K RAM is also used as a scratch pad for the Z80 CPU and for storage of code used to load the odd and even pin registers.

Data Bus lines D0-D7 comprise an 8 bit bidirectional bus used to transfer data between the Z80 CPU, and the PI/O.

2.2.3 Printer Prime F/F

The Printer Prime F/F (L13) is set by the host system to reset the printer logic prior to commencing a printout by issuing signal STB A. The software reset of the Prime F/F is recognized by the Z80A when input port B (bit 2) is set. The Prime F/F is checked during power-up as one of the self tests by Test PFF (Test Prime F/F, IN "03") and reset by the Z80A CPU software.

2.2.4 Data Strobe F/F

When the host 2200 system sends an eight-bit code (D0-D7) to control the printer or hex code for printing, the following steps occur:

Data is placed on data bus A and clocked into the PI/O in parallel formatted bytes. After the data bus has settled, the host system will send a data strobe (STB A) which strobes the data into the PI/O. It will also set the Data Strobe F/F (L13). The data strobe F/F activates bit 3 of input port B and also sends a Busy signal back to the host system. The BUSY signal is part of the handshaking communication between the printer and host system. If the printer has been SELECTED, the printer CPU checks port B, bit 3 for a hex coded byte from the host system.

If bit 3 is inactive, the program will loop and keep checking as long as the select switch is set. If bit 3 is active, hex code is loaded in the PI/O, the Z80A will read the (A) port and store it in RAM. Once the byte is read, the PI/O will trigger the one-shot Acknowledge (ACK) F/F L31 which resets the Data Strobe F/F and sends an ACK (handshake) signal to the host computer indicating receipt of the byte. This procedure continues until all data has been received by the printer. The Data Strobe F/F is checked during power-up as one of the self tests. It is set by test signal DSFF (Data Strobe F/F, IN 02) and reset by the ACK oneshot.

2.2.5 Home Sensor

The home sensor is used to index the same left hand travel limit. The output of the home sensor is routed to port B, bit 5 of the PI/O used to inform the Z80A that the print head is at the home position for a new line of print. The home sensor also clears the Column Strobe Control (L31).

2.2.6 Right Sensor

The right sensor sends a signal to PI/O port B, bit 6. The right sensor is used as a starting reference for printing in the reverse direction.

2.2.7 Column Strobe Control

To print a line of characters, the following will occur:

The print head is at the home position. The home sensor clears the Column Strobe Control (L51). The Z80A instructs the carriage servo motor to go forward which turns the strobe wheel generating column strobos which are not recognized until gated by the index strobe. Once the print head has moved beyond the home sensor, the column strobe control will no longer be cleared. The column strobos are not recognized until the first index strobe passes the home sensor which enables the column strobe control permitting the strobos to be sent to the PI/O port B, bit 4. There are 110 column strobos per revolution of the strobe wheel.

At the point of starting to print, the Z80A will be in a loop looking for bit 4 of port B of the PI/O to be active. If it is active, an IN 05 will then be issued to clear the Column Strobe F/F. Bit 4 when active also informs the Z80A to load and fire the proper pins on the print head. This will continue for data being printed on this particular line.

2.2.8 Driver/PS Regulator PCB (P/N 210-7594)

The servo control block 7594 represents the Driver/PS Regulator PCB. The Servo Control block controls the direction and speed of the servo motor, moves paper by pulsing the paper stepper motor and controls printing by enabling the odd and even pin registers.

To move the carriage assembly forward (FWD) at a controlled velocity requires the Fwd F/F to be set by command OUT 01 with the Feedback F/F set by data bit $D_1=1$. With Data Bit $D_1 = 0$ the velocity of the servo motor is controlled only by the column strobos. An OUT 01 command (FWD) when issued will set the Fwd F/F and the Feedback F/F to move the carriage assembly from left to right. To reverse the direction of travel would require an OUT 02 command. The OUT 02 command resets the Fwd F/F and sets the Rev F/F.

The servo motor, which drives the strobe wheel, utilizes the column strobe from the strobe wheel for feedback control. Reverse travel of the servo motor driven carriage assembly and reverse printing is dependent on the position of the carriage at the time of reversal. The carriage will reverse direction or continue to the right sensor depending on the proximity of the carriage with respect to the home sensor or right sensor.

The servo will only move under the control of the Z80A processor. Software controls determine when the carriage will move, stop, direction of travel, carriage speed and printing. The printer(s) can print in both forward and reverse directions.

2.2.9 Print Head Operation

The operation of the print head is controlled by the following control blocks located in the right lower section of Figure 2-1.

1. Odd pins register (L61)
2. Even pins register (L62)
3. Pin drivers
4. Fire pins F/F (L9)
5. Pin fire control (L6, L35)

The print operation of a matrix character by selecting 10 or 12.2 pitch is discussed in the following steps:

Column strobes are not enabled until the INDEX STROBE of the strobe wheel has enabled column strobe control. The first column strobe, when detected by the PI/O, initiates a routine to print the first part of a character. Characters are printed in 7x9 or 9x9 matrices, dependent on pitch selection. A 7x9 matrix would require 7 firings of the Odd and Even pins of the print head to complete one character.

The Z80A accesses the desired pitch PROM font for both the odd and even pins of the first vertical print pass of the character matrix. The first part of the desired character to be printed will be accessed from the PROM and loaded into the Odd and Even pin registers (L61 and L62) sequentially via the data bus.

The five odd bits (1's and 0's) are loaded into the odd pins register (L61) by OUT 03 followed by four even pin bits loaded into (L62) by OUT 04 command. OUT 04 triggers the Fire Pin F/F which fires the odd and even pin drivers simultaneously on the print head. This procedure repeats for each line of characters which is the time it takes for the print head to travel from the home position to the right sensor or computed end of the line.

During the printing sequence the Pin Fire Control (L6, L35) counters count 3 MHz clock pulses. When a predetermined count is reached, the pin fire control will reset the Fire Pin F/F L9. This disables the outputs of the Odd and Even pin registers turning the pin drivers off. The pin drivers are on the Pwr Driver PCB P/N (210-7594).

2.2.10 Keyboard Input Register

Keyboard control switches, when depressed, provide signals which are processed when command decode IN 00 is issued, gating the switch code onto the data bus. If the printer is selected (on-line), and the Clear switch is illuminated, deselect the printer and press the Clear switch which clears the line buffer. Reselect the printer.

The four switches in the upper right top row illustrated in Figure 2-1 are on the control panel for Models 2233/2235 used with 2200 Host Systems.

2.2.11 Cover Open/Paper Out Register

The Cover Open (CO)/Paper Out (PO) register (L56) has inputs from individual switches activated by the conditions of a cover open or a paper out situation. An IN 01 command from the Z80A will present either of these conditions on the front control Panel (LEDs). If the cover open switch is activated, the printer will complete the current line and return the print head to the home position. If the paper out switch is activated, a software error will light the Forms-Override LED.

2.3 MODEL 5533/5535 DOT MATRIX PRINTERS

The following paragraphs describe operation of the 5533/5535 "serial" Dot Matrix Printers. The descriptions are based on the following functional blocks:

- Direct Memory Access
- PIO CPU PCB 210-7348
- Data Link PCB 210-7446
- RAM Memory

2.3.1 Direct Memory Access

The transfer of serial data to and from the host system and the printer, is via DMA operation. The maximum amount of data bytes transferred during one DMA operation is 256 bytes (referred to as a block or page of data). A single byte is the minimum data to be transferred during a DMA. Each of the six (6) DMA operations require an instruction byte to be decoded internally within the printer device to set the conditions for processing each of the six instructions.

2.3.2 PIO CPU PCB (P/N 210-7348)

The PI/O CPU PCB board provides conversion of serial data from the host system to parallel data for internal use. The parallel data consists of two address bytes for each data byte to be printed. Each data byte is written into the specified address of the RAM memory board P/N (210-7547). Data retrieved, (read) from memory via a DMA operation, requires conversion from parallel to serial for processing by the host system.

The 8080 CPU (L15) processes and issues the two byte address followed by the single byte of data loaded into RAM memory for a 1-byte write command. If the command instruction is a 256-byte write then the number of bytes stored will be 256 bytes.

2.3.3 Data Link PCB P/N (210-7446)

The Data link PCB is the data link control logic for decoding six DMA instructions. The instruction bytes are identified as follows:

1. Status
2. Restart
3. 1-Byte Read
4. 1-Byte Write
5. 256-Byte Read
6. 256-Byte Write

Handshaking controls for Port A of the Z80A-PI/O are initiated by the Data Link PCB. The handshaking and control signals are:

- Select
- DSTB (Data Strobe)
- Busy
- Acknlg (Acknowledge)

A Data Strobe (DSTB) signal is generated by an OUT 0A command from L28 and L14 which loads a byte of data into the PI/O. Signal (A RDY) from the PIO, when active, indicates that the PORT A output register has been loaded and the peripheral data bus is stable and ready for transferring a byte of data.

Signal A RDY triggers logic that produces a Busy signal which is sent to the Data Link PCB while the data byte is gated onto the Z80A data bus. An Acknowledge (ACK) is triggered after the data is transferred to the Z80A when A RDY is no longer active. ACK is wired to ACKNLG on the Data Link PCB. This procedure repeats until the printer has completed printing the complete document.

The instruction register (L4, L5) recognizes only the instruction bytes, which when decoded, provide byte timing, DMA timing, sets receive or transmit modes of operation and clears the data link after each operation. Data output registers (L29 and L31) provide the print data via Port A of the Z80A-PIO. (The same 8-bit input port used by parallel printer models).

2.3.4 RAM Memory PCB P/N (210-7547) (210-7847-A)

The RAM Memory board provides interim temporary storage of print data transmitted serially for printers designed to be used with WP and OIS systems. The data is stored and retrieved by the 8080 CPU processor used in the 5533/5535 model printers. The 8080 CPU controls the data to be output by the Data Link.

2.3.5 Select Switch

The select switch for 5533/5535 Models is wired direct to the Select F/F (L35) on the Data Link PCB. This change resulted in the removal of two 10 ohm resistors R7 and R21 shown in Figure 4-1. The resistors, when removed, isolate the Select F/F L3 on the CPU I/O PCB used with 2233/2235 model printers. The Select F/F L35 now initiates the transfer of data from the RAM memory to the printer. The select signal commences the transfer of data via the 8080 CPU (L15) data bus which is accessed from the RAM memory. Each data byte is clocked into data output registers (L29) and (L31) by an OUT 08 command onto the Port A bus of the Z80A-PIO.

COMPOSITE 3-BOARD DATA LINK

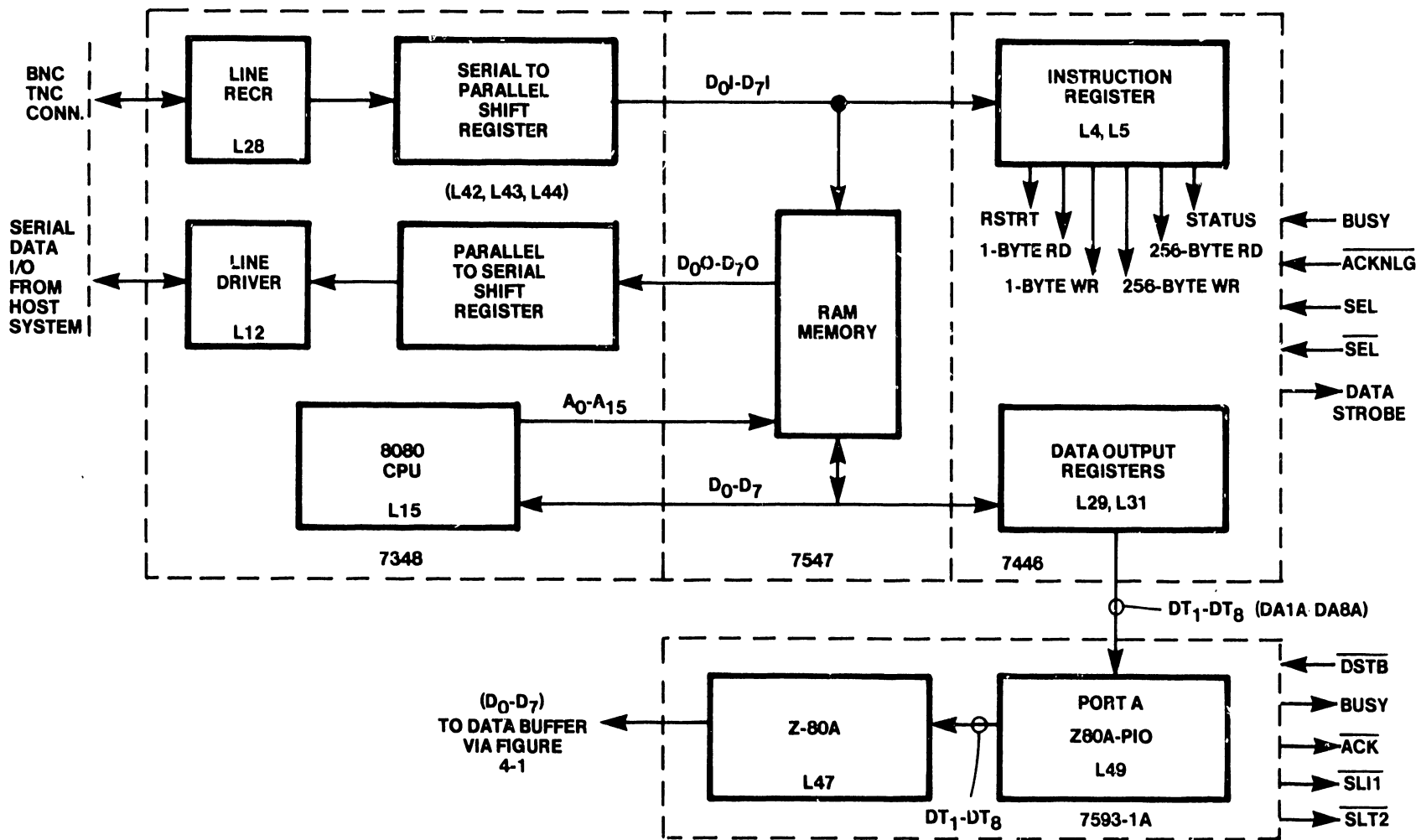

D_0I-D_7I = DATA IN TO DATALINK

D_0O-D_7O = DATA OUT FROM DATALINK

DT_1-DT_8 = DATA TO PRINTER

D_0-D_7 = DATA I/O FROM CPU'S Z80A & 8080

Figure 2-2 Serial Data Link (Models 5533/5535)

CHAPTER

3

OPERA-

TION

CHAPTER 3 OPERATION

3.1 INTRODUCTION

Chapter 3 describes Models 2233x/2235x and 5533x/5535x printer controls and indicators, power-up sequence, ribbon cartridge mounting, and paper loading procedures.

3.2 MODEL 2233x/2235x CONTROLS and INDICATORS

The Model 2233x/2235x Matrix Printers contain identical switches that control printer operations and indicators that indicate printer status (refer to Figure 3-1).

3.2.1 ON/OFF Switch and Power Indicator

The ON/OFF switch is located on the right side of the printer rear panel as viewed from the front. To turn the power ON, press the ON side of the rocker switch. The POWER indicator lamp illuminates on the front control panel. Press the OFF side of the rocker switch to turn power off.

3.2.2 Select Switch and Select Indicator

The SELECT switch is located on the front control panel. When pressed once, the SELECT switch places the printer in the READY condition to receive data from the host system. When the printer is ready to receive data, the indicator lamp at the upper right corner of the SELECT switch is illuminated.

When pressed a second time, the SELECT switch deselects the printer and extinguishes the indicator.

The printer will finish printing the line before it will stop. Therefore, the SELECT switch can be used to halt printing temporarily without causing data loss in the print buffer (for example, when aligning forms or changing a ribbon cartridge).

NOTE: Though the SELECT indicator lamp is illuminated and the printer is enabled to receive data, it must still be selected as the system printing device by using the BASIC language execution of a SELECT statement. Refer to Appendix C for instructions on the method of how to SELECT either Model 2233x/2235x for a printout.

3.2.3 Line/Feed Switch

The LINE FEED switch is located on the front control panel. This switch operates only when the printer is deselected and the SELECT indicator is extinguished. When this switch is pressed and released, paper is advanced one (1) line. When the switch is pressed and held in, paper advances continuously.

3.2.4 Top Of Form Switch

The TOP OF FORM switch is located on the front control panel. This switch operates only when the printer is deselected and the SELECT indicator is extinguished. When the TOP OF FORM switch is pressed, paper is automatically advanced to the top of the page. Refer to Chapter 5 of Appendix C for instructions on setting the TOP-OF-FORM position automatically using the Direct Access Vertical Format Unit (DAVFU).

3.2.5 Form Override Switch and Paper Out Indicator

The FORM OVERRIDE switch is located on the front control panel. This switch operates only when the printer is deselected and the SELECT indicator is extinguished. It is used to complete printing a page after the printer has sensed a paper-out condition. When out of paper, the printer stops and the Paper-Out indicator lamp is illuminated which is located on the upper right corner of the FORM OVERRIDE switch. If the printer is then deselected, the printer will print one line each time the FORM OVERRIDE switch is pressed.

3.2.6 Clear Switch and Indicator

The CLEAR switch is located on the front control panel. Pressing this switch clears the printer line buffer. The CLEAR switch operates only when the printer is deselected and the SELECT indicator is extinguished.

The CLEAR switch may also be used to extinguish the diagnostics error indicators (refer to diagnostics error indicators in Paragraph 4.5.1).

The MALFUNCTION indicator located at the upper right corner of the CLEAR switch, when illuminated, signals that a hardware error has been detected by diagnostic routines run by the printer when the power ON switch is pressed. If the diagnostic routines run successfully, a beep tone is sounded. When a hardware error is detected, the diagnostics illuminate binary coded error indicators located to the right of the control panel (visible when the front printer cover is raised).

If the printer stops operating and the malfunction indicator is on, deselect the printer, press the CLEAR switch, then press the SELECT switch. Repeat the above procedure several times. If the MALFUNCTION indicator remains on, check to see which of the error indicator codes are on, then refer to Chapter Four, Table 4-1 to identify the error code.

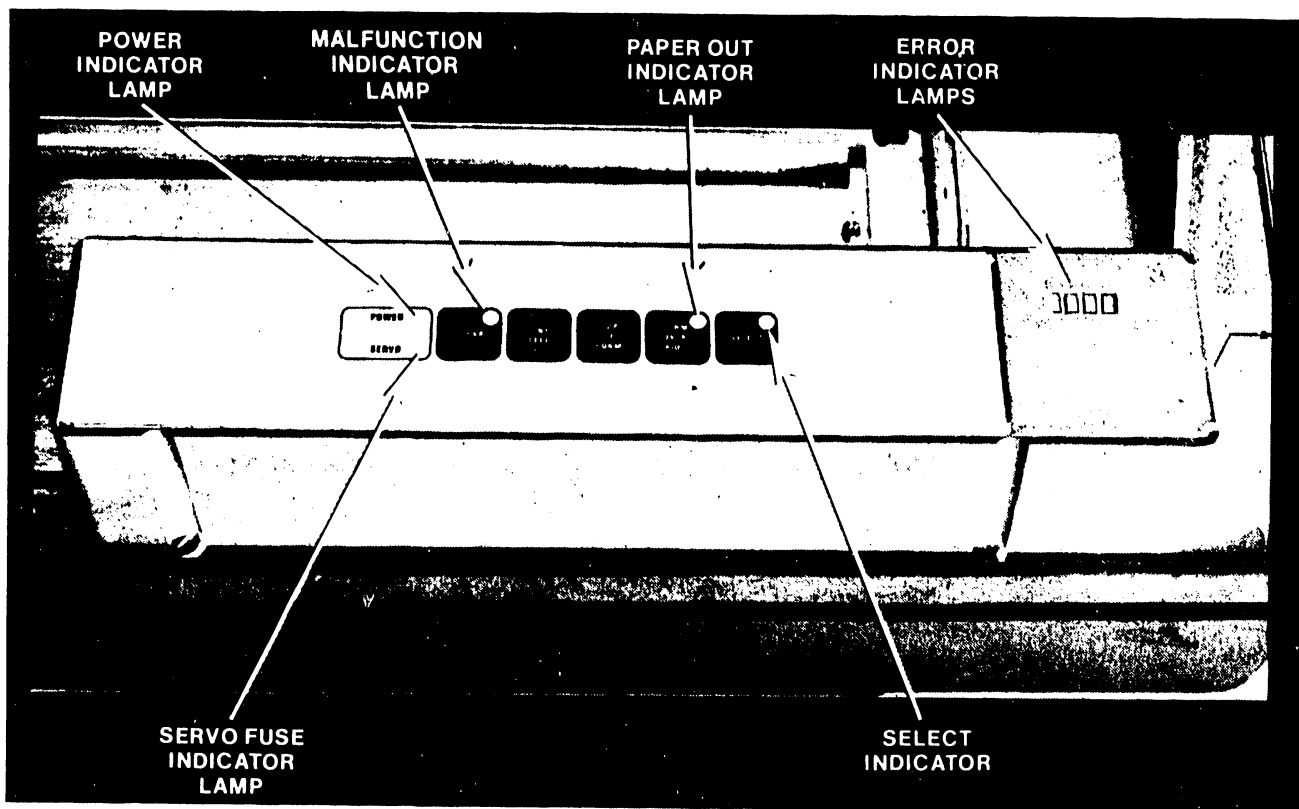

Controls and Indicators Model 2233/2235

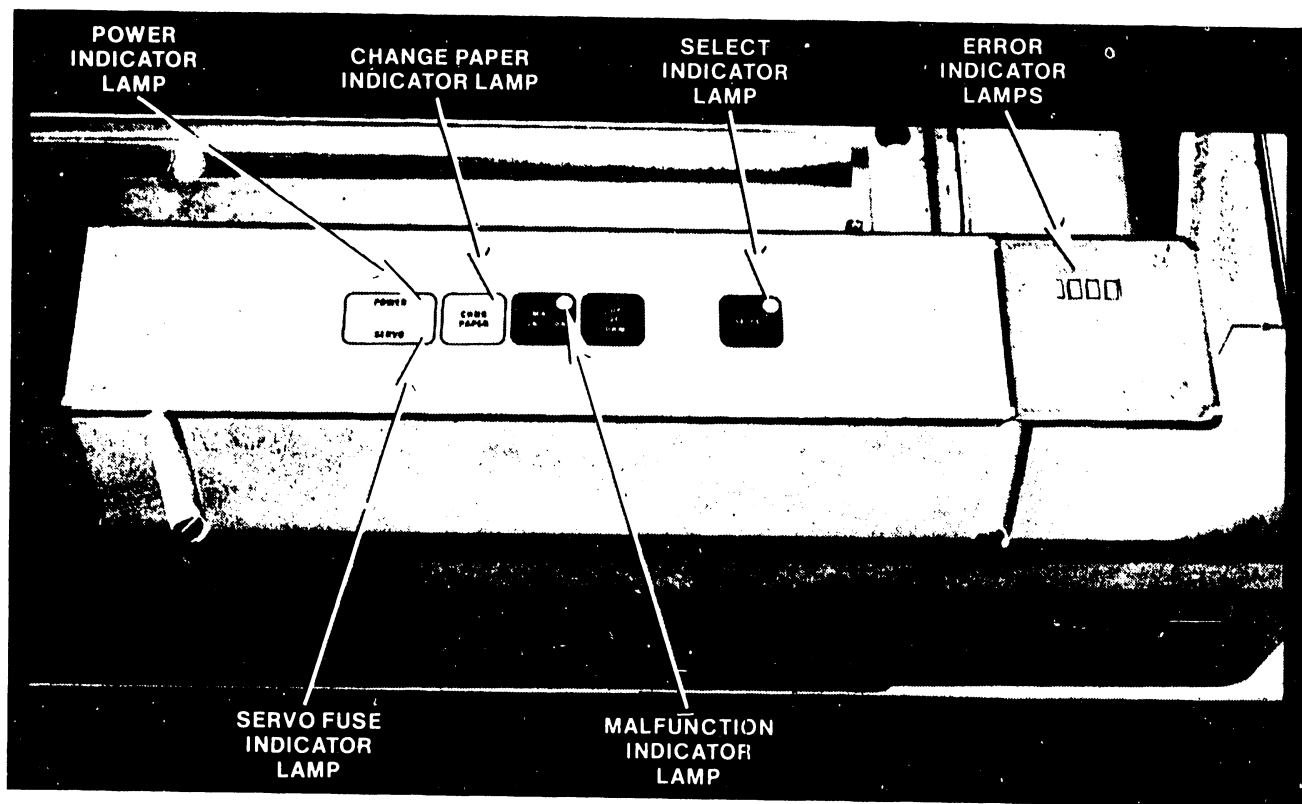

Figure 3-1 Controls and Indicators Model 5533/5535

3.2.7 Servo Fuse Indicator

When illuminated, the SERVO fuse indicator located at the far left of the printer front panel indicates the time necessary before the 50V power supply voltage drains off.

3.3 MODEL 5533/5535 CONTROLS and INDICATORS

The Model 5533/5535 Matrix Printers contain switches that control the manual operations of the printer and a series of indicators that signal printer status refer to Figure 3-1.

3.3.1 ON/OFF Switch and Power Indicator

The ON/OFF switch is located in the left corner of the printer rear panel. To turn the printer ON, press the ON side of the rocker switch. This illuminates the POWER indicator on the printer front control panel. To turn the printer OFF, press the OFF side of the rocker switch.

3.3.2 Select Switch and Select Indicator

The SELECT switch is located on the printer front control panel. The SELECT switch is pressed to initially activate the printer or restart the printer after it has been manually or automatically deselected. When the printer is able to receive text from the Word Processor (WP), Office Information system (OIS) or VS System, the indicator at the upper right corner of the SELECT switch is illuminated.

Pressed a second time, the SELECT switch deselects the printer and extinguishes the indicator. The printer will finish printing the line and then stop. The SELECT switch can be used to halt printing temporarily without causing data loss in the print buffer (for example, when aligning forms or changing ribbon).

3.3.3 Top Of Form Switch

The TOP OF FORM switch is located on the printer front control panel. This switch operates only when the printer is deselected and the SELECT indicator is extinguished. Initially, paper should be adjusted manually to the paper top of form position by turning the platen knob, located on the left side of the platen, until the desired top of form is reached. Subsequently, when the TOP OF FORM switch is pressed, paper is automatically advanced to the top of the next form.

The TOP OF FORM switch has a major advantage, when at some point on a page an alignment problem is noticed, the entire page can be reprinted, provided the last line of the page has not yet been printed. To reprint the page, deselect the printer. Press the TOP OF FORM switch; the printer will eject to the top of the next page. Next, reselect the printer; the entire page will be reprinted.

3.3.4 Change Paper Indicator

When near the end of continuous form paper, the printer stops, sounds an audible tone and illuminates the CHANGE PAPER indicator lamp on the front control panel refer to Figure 3-1. When paper runs out, insert more paper and press the SELECT switch. To print more lines on the existing page, press the Select switch once for each line.

3.3.5 Malfunction Indicators

The MALFUNCTION indicator is located on the printer front control panel. An illuminated MALFUNCTION indicator signals that a hardware error has been detected by diagnostic routines run by the printer. Refer to Chapter Four, Table 4-2 to identify the error. If the diagnostic routines run successfully, a beep tone is sounded.

3.3.7 Servo Fuse Indicator

When illuminated, the SERVO FUSE indicator located at the left of the front control panel indicates the time necessary before the 50V power supply voltage drains off.

If the servo fuse blows, it is typically caused by a paper or ribbon jam. To recover from this condition, replace the fuse and turn the printer power ON. If the new fuse blows, check the power supply or the Pwr/Driver PCB P/N (210-7594).

3.4 COVER OPEN SWITCH

The cover open switch shuts off servo power when the operator raises the printer cover. The Cover Open LED error sequence (1011) will be displayed when the printer cover is open.

It is possible to disable this switch when performing service procedures by pulling upward on the cover open switch plunger. The VFU error sequences (0100, 0110) indicate an error in the coding of the Vertical Format that can be corrected by the user. Refer to Appendix C for a discussion of the Direct Access Vertical Format Unit (DAVFU).

3.5 PAPER LOADING (All Models)

1. Deselect the printer
2. Raise the printer cover and lock the support bar.
3. Pull the print head retraction lever downward toward the front of the printer to move the print head away from the striker bar.
4. Hand feed a sheet of the continuous-form pin-feed paper into the slot at either the bottom or bottom front of the printer until it appears between the pin-feed gates. If the distance between the pin-feed gates must be adjusted, push the gate adjustment levers upward and slide the gates to the proper positions. Slide paper through the slot at the base of the printer cover to rest flat on the back of the printer.

5. Open the pin-feed gates. Pull the paper and engage the first four holes evenly on the tractor pins beneath both pin-feed gates.
6. After the paper is in position, close the pin-feed gates, raise the print head retraction lever to the point where it contacts the forms thickness lever.
7. For proper vertical positioning of paper, use the platen knob located to the left of the platen and manually roll paper for the desired top-of-form position. Paper perforation should line up to top edge of striker bar.
8. Fine vertical adjustments can be made when the platen knob is pulled out and rotated. While holding out the platen knob, press the TOP OF FORM switch. When the TOP OF FORM switch is pressed, paper is automatically advanced to the top of the next form.

NOTE: For Models 2233/2235, TOP OF FORM position can also be set programmably by the Direct Access Vertical Format Unit (DAVFU). Refer to the Appendix C, Chapter 5 for more detail regarding DAVFU. Press the TOP OF FORM switch to automatically advance the paper until the Vertical Format Unit reaches the specified top-of-form encoded in the DAVFU. The default page length is 66 lines.

3.6 RIBBON CARTRIDGE REPLACEMENT (All Models)

Perform the following procedure to replace the ribbon cartridge.

1. Deselect the printer.
2. Raise the printer cover. Pull the middle of the cover support bar assembly forward to the locked position as shown in Figure 3-2.
3. Locate the print head retraction lever to the left of the print head carriage (Figure 3-2). Pull this lever toward the front of the printer to move the print head away from the striker bar.
4. Move the print head carriage about 2" (5 cm) to the right for better accessibility to the ribbon cartridge.
5. Remove the cartridge by pulling the cartridge release toward the front of the printer as shown in Figure 3-2. Lift the cartridge up slightly and remove it from the printer.
6. To replace the new cartridge, tighten the ribbon by rotating the knob in the direction shown by the arrow on the cartridge casing.

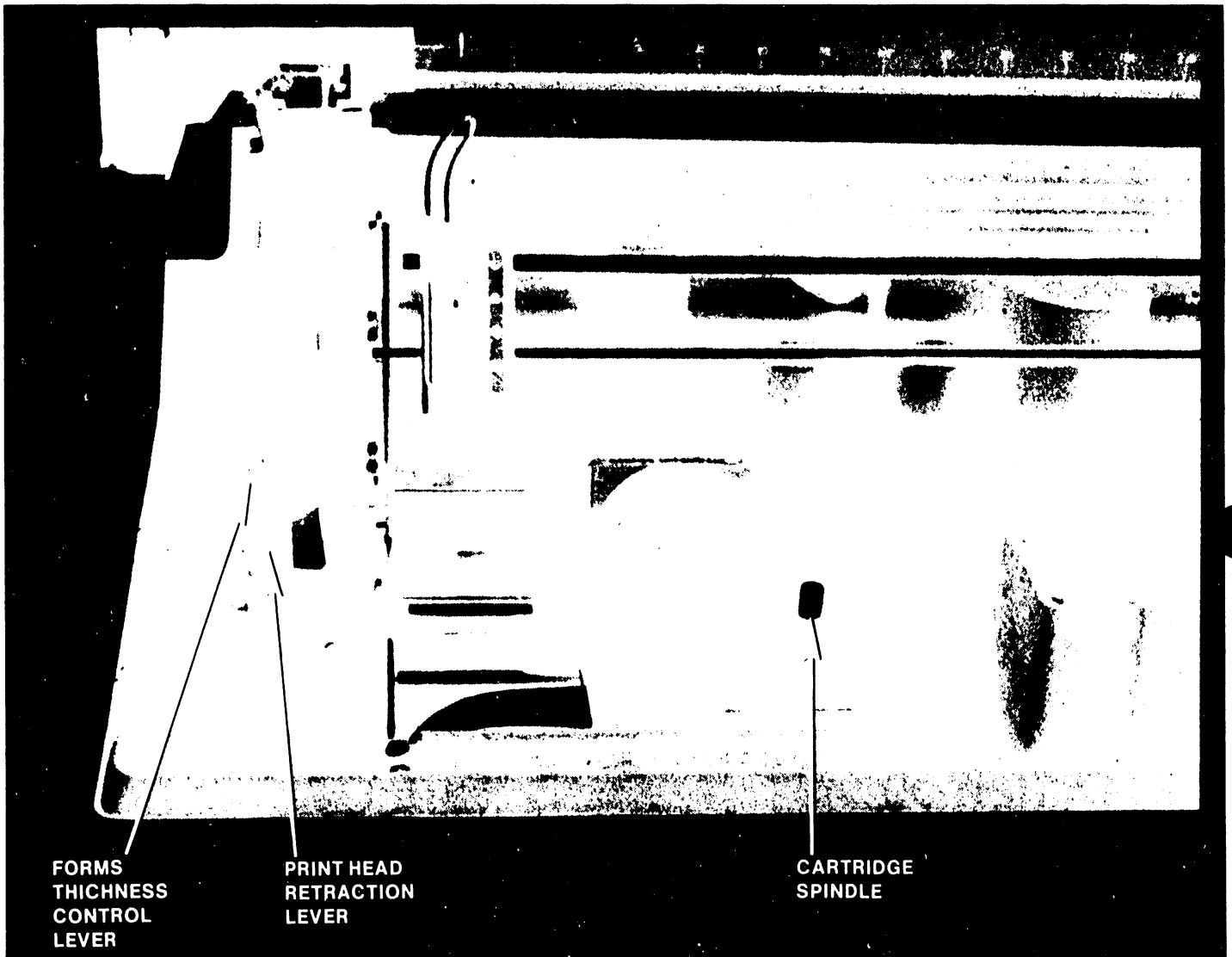

Figure 3-2 Ribbon Cartridge Removal

7. Lower the cartridge onto the print head carriage so that the ribbon passes in front of the print head ribbon guide. While holding the cartridge in the horizontal position, pull it toward you about 1/4" until the front of the cartridge drops into the brackets refer to Figure 3-2. Push the cartridge down until the carriage release locks the cartridge into position. Insure the cartridge is securely locked and the ribbon drive is engaged by rotating cartridge knob.
8. Raise the print head retraction lever to the point where it contacts the forms thickness lever. When the ribbon is replaced, the print head retraction lever is the only adjustment lever that is required to move.
9. Close the printer cover by pushing the hinge at the middle of the cover support bar, and lower the cover.
10. Select the printer and resume printing.

3.7 PRINT ADJUSTMENT

To adjust the print intensity for different form thicknesses, perform the following procedure:

1. Prior to print adjustment, be sure that the proper form paper is loaded and the power switch is OFF.
2. Raise the cover of the printer to the locked bar position.
3. Locate the forms thickness lever refer to Figure 3-2. Note that the forms thickness lever has nine position notches for variable print adjustments. When the lever is positioned towards the rear of the printer, the print head moves closer to the striker bar. When the lever is positioned toward the front of the printer the distance between the striker bar and the print head increases.
4. Position the forms thickness lever towards the rear of the printer to darken the imprint and accomodate single forms. Conversely, moving the lever to the front will lighten the imprint and accomodate thicker or multiple forms.
5. When the print head has been properly adjusted, close the printer cover. The printer operates only when the cover is closed. If, during printer operation, the paper does not feed smoothly because it catches on the front surface of the print head, set the forms thickness lever toward the front one additional notch.

NOTE: After replacing a new ribbon, start the print head Forms Thickness at setting 5 and adjust accordingly for best print results. Position 1 does not indicate use of 1 part paper. Position 2-3 are the normal position for 1 part paper.

3.8 OPERATING CHARACTERISTICS

Refer to the following Table for reference to printer speed pitch settings and applicable dot matrix printing formats.

Table 1-3
Printing Speeds

Printer	Speed	Pitch	Matrix Format
All xx33x	100 CPS	10P =	9x9 dot matrix
	120 CPS	12P =	7x9 dot matrix
All xx35x	180 CPS	10P =	9x9 dot matrix
	222 CPS	12P =	7x9 dot matrix

3.8.1 Pitch Selection

The Carriage Return Line Feed (CRLF) is used for pitch selection only. The above switch setting produces the following default pitch selections for each printer model.

Table 2-3
Pitch Selection

Model	Default	CLRF Switch Setting
2233	12.2	Don't Care **
2235	10	OFF
	12.2	ON
5533	12.2	Don't Care **
5535	10	OFF
	12.2	ON*

*12.2 pitch is not supported on WP/OIS Systems or VS Systems operating in word processing.

** Unless JP1 on the CPU Board P/N (210-7593xx) is installed.

CHAPTER

4

**INSTAL-
LATION**

CHAPTER 4 INSTALLATION

4.1 INTRODUCTION

Chapter Four supplies information necessary to unpack, pack and install Dot Matrix Printer Models 2233/2235 5533/5535. Diagnostic test procedures are also provided. Site considerations are not provided in this manual; refer to Wang Site Preparation Manual for recommendations when installing Wang printers.

4.2 UNPACKING, PACKING and INSPECTION

Verify that the following items are provided in the shipping container

- Paper Rack
- Box of Paper
- Power Cord
- Parallel or Serial Interface Cable
- Two ribbons cartridges
- Printer User Manual

When installing the printer, ensure that the ventilation openings on the left and right sides of the printer are unobstructed.

4.2.1 Unpacking

1. Cut the packing straps and remove the printer from the box. Refer to Figure 4-1.
3. Remove the fitted left and right hand styrofoam inserts used to secure the printer in the shipping container.
4. Remove tape that secures the paper rack, interface cable and power cord to the cardboard used to protect the top cover. Remove the rack, cable, power cord and cardboard from the top cover and set aside.
4. Lift the printer from the styrofoam base and the plywood base.
5. Store the shipping material in the event that the printer is reshipped.

NOTE: Inspect the Printer for damage. If damage is evident during this or subsequent inspections, file an appropriate claim with the carrier and notify the WLI Distribution Center (Dept. #90), Quality Assurance Dept., Mail Stop 2636.

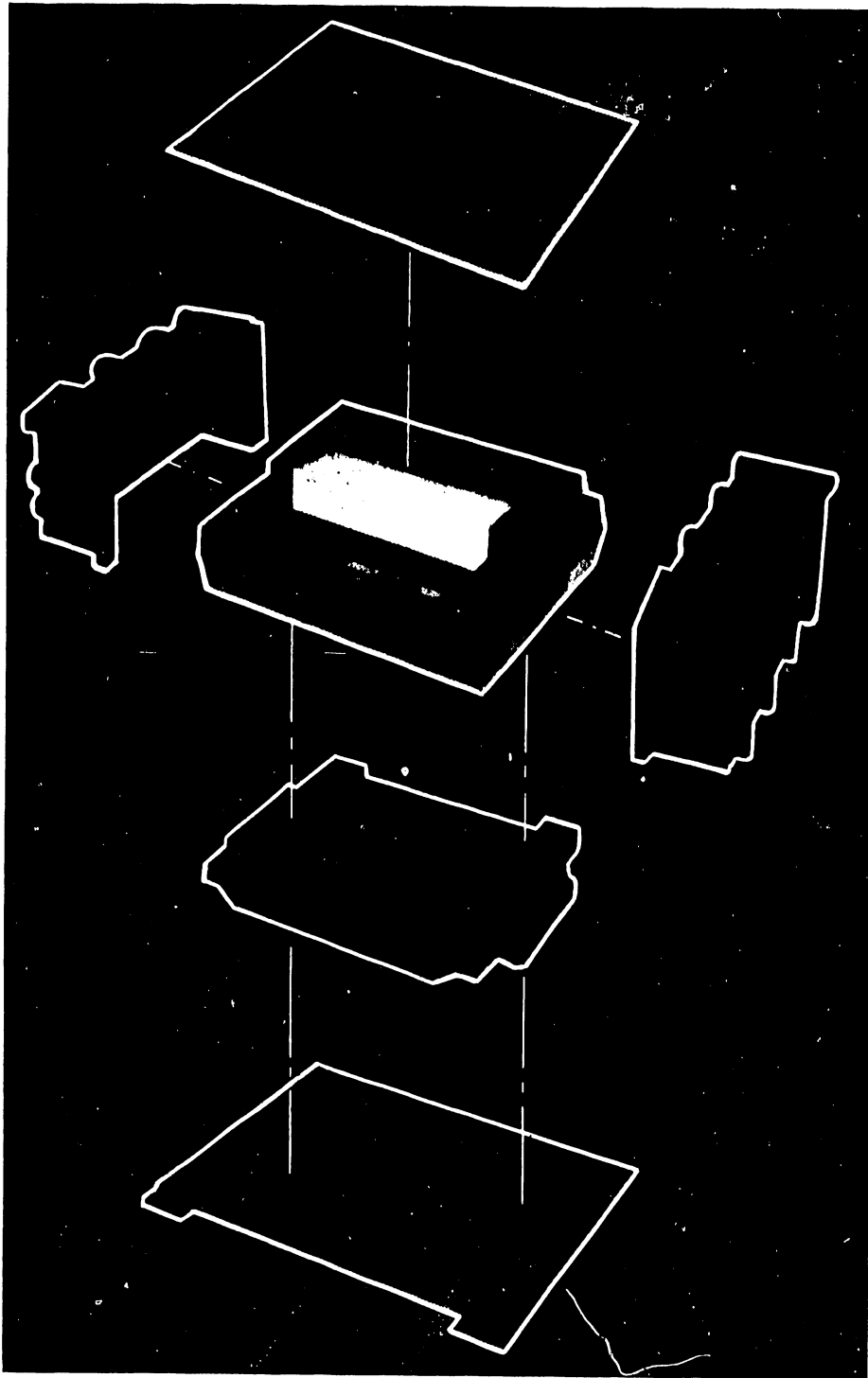

Figure 4-1 Packing Unpacking

4.2.2 Packing

1. Place the plywood and styrofoam bases on a flat surface. Refer to Figure 4-1.
2. Set the printer on the styrofoam base.
3. Fit the left and right hand styrofoam inserts to the printer.
4. Set the cardboard section on the top cover.
5. Wrap the paper rack in shipping material and place on the cardboard with interface cable and power cord. Secure with tape.
6. Fit the shipping container over the printer and secure the printer to the container with strapping.

4.3 Initial Printer Checks and Adjustments

Perform the following procedures to inspect the printer before connecting it to a power source. Refer to Appendix D for reference to printer interconnect diagrams for all models.

NOTE: Before connecting the printer to a power source ensure that the source voltage and line frequency are compatible with the power requirements of the printer.

1. Loosen the two captive thumbscrews located on the rear panel of the printer. See (Figure 4-2), item (A) for screw location.
2. Open the front top cover of the printer to the latched position. Pull the middle of the hinged cover support bar Figure 4-2, item (B) forward until the bar locks into position.
3. Disengage the top end of the cover support bar by gently pulling the bar sideways off the ball head retaining pin. If the rubber grommet becomes detached, reinstall it in the bar Figure 4-2, item (C).
4. Release the top cover by pulling forward on the top edge of the plastic tabs located on the right and left sides of the printer Figure 4-2, item (D). Carefully lift the cover from the printer.
5. Check the 115/230 voltage selector plug Refer to Figure 4-3.
6. Remove the Phillips-head screw to remove PC Board retaining cover to access the PCBs.

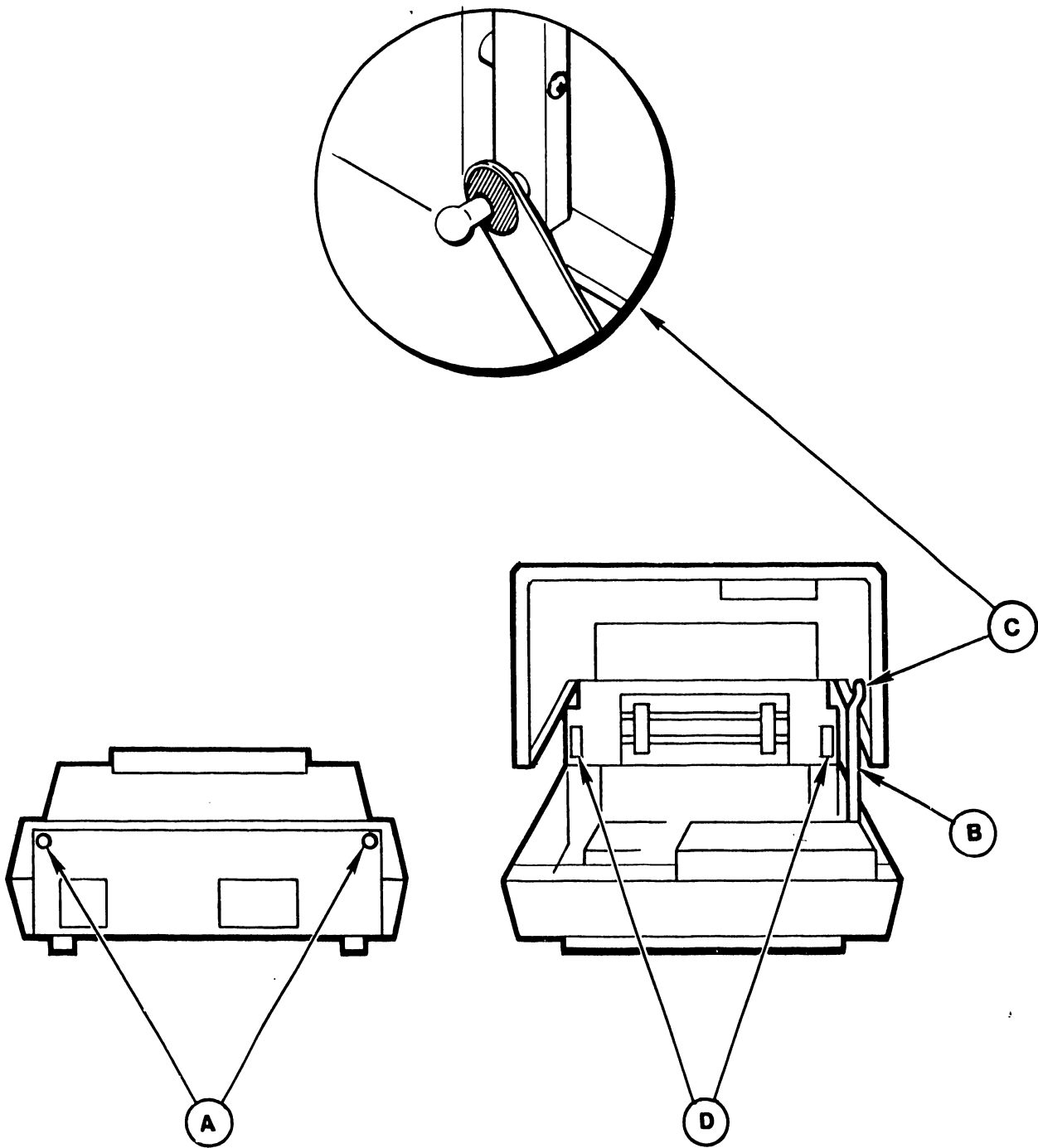

Figure 4-2 Top Cover Removal



Figure 4-3 Voltage Selector Plug

7. Remove the appropriate PCB to set switch settings and check jumpers for normal operation as follows:

2233 Printer:

No PCB switch settings or jumpers.

2235 Printer:

CPU PI/O PCB P/N (210-7593B), (210-8393B)

SW 5 on the keyboard becomes active with JP1 installed as described in Chapter 1, Section 1.3 also see Figure 4-4.

PWR/Driver PCB P/N (210-7594)

With (JP1 and JP2) on the Pwr/Driver Board installed, the printer is configured to operate as the higher speed xx35 version. When not installed the printer is configured to operate as the lower speed xx33 version. Refer to Figure 4-5.

5533 Printer

PIO CPU P/N (210-7348)

Required switch settings are shown Figure 4-6.

Data Link PCB P/N (210-7446)

Required switch settings and jumper configurations are shown in Figure 4-7.

5535 Printer: Same switch settings as described above for Model 5533 and the additional settings that are described below:

CPU PI/O PCB P/N (210-7593B), (210-8393-1B)

SW 5 on the keyboard becomes active with JP1 installed as described in Chapter 1, Paragraph 1.3, also see Figure 4-4.

PWR/Driver PCB P/N (210-7594)

With (JP1 and JP2) on the Pwr/Driver Board installed, the printer is configured to operate as the higher speed xx35 version. When not installed the printer is configured to operate as the lower speed xx33 version. Refer to Figure 4-5.

8. Install PCBs and check that all cable connections are intact.
9. Remove tape used to secure the print head carriage.
10. Ensure that the proper voltage selector plug refer to Figures 4-3 is installed prior to plugging in the power cord. Set the printer power switch on the rear panel to the OFF position. Connect the printer power cord to a standard three-prong power outlet.
11. Set the printer ac power ON/OFF switch to ON.
12. Perform the power supply voltage checks and adjustments contained in Paragraph 5.3.17.
13. Install the ribbon cartridge and load paper forms in the printer Chapter 3, Section 3.5 and 3.6. Also, read descriptions of printer operating controls.
14. Perform the carriage speed check and adjustment contained in paragraph 5.3.
15. Set printer power ON to perform the FIVE-LINE TEST procedure . When the printer power switch is turned to ON, a momentary beep should be heard from the printer indicating that it is ready to print. Refer to Section 4.5 for more detail regarding the Five - Line Test and Figure 4-9 for a printout of test results.

Model 2233/2235:--Press and hold the FORM OVERRIDE switch, then press the LINE FEED switch. Five lines of test characters will be printed.

Model 5533/5535:--Press and hold the MALFUNCTION switch; then press the TOP OF FORM switch. Five lines of test characters will be printed.

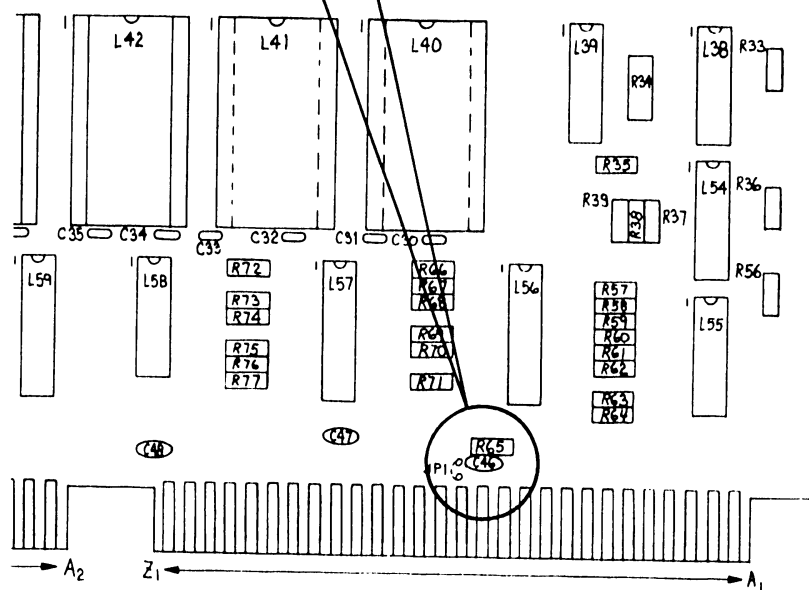
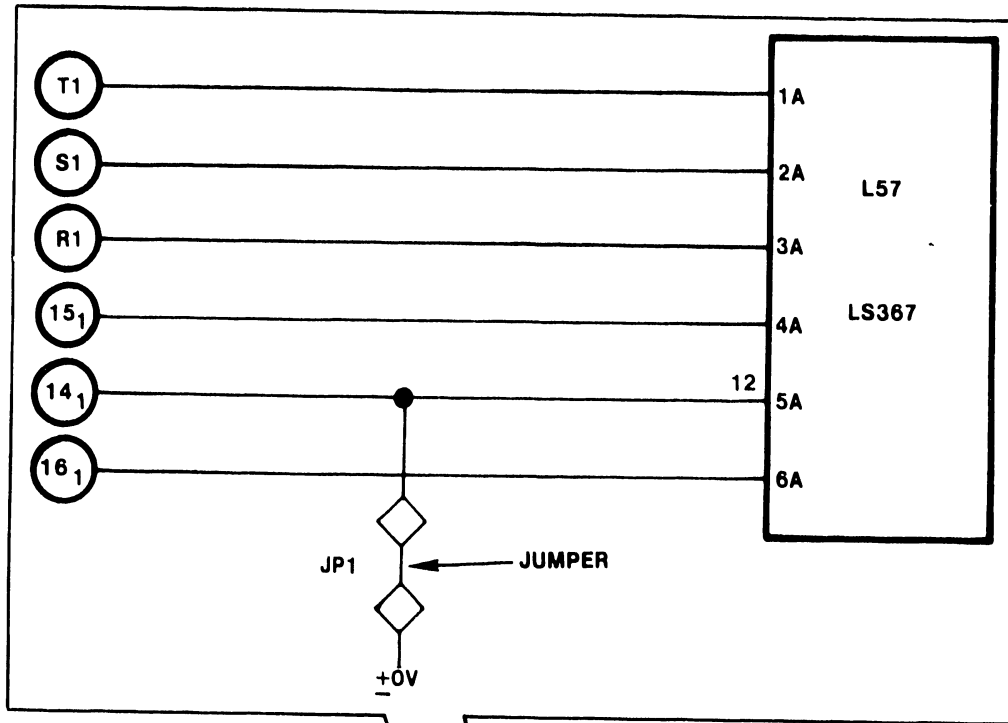

Figure 4-4 J1 Installation CPU PI/O P/N (210-7593B), (-1B)

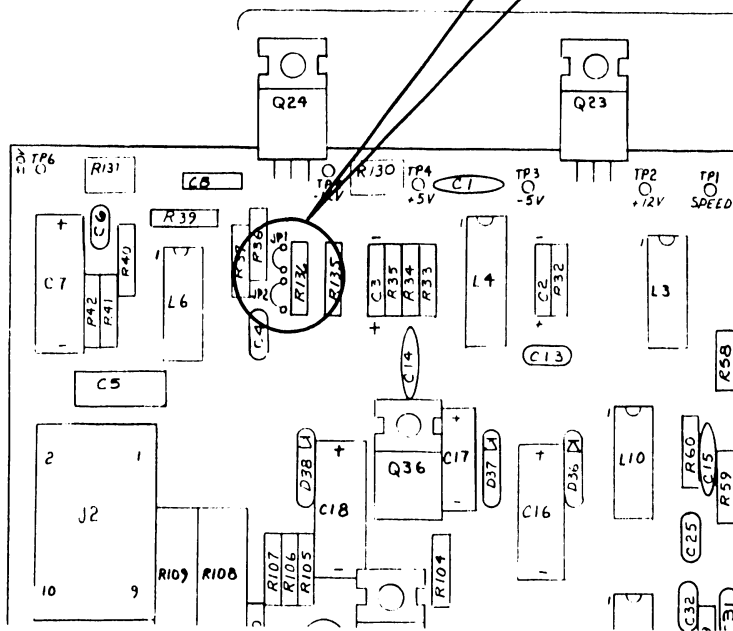
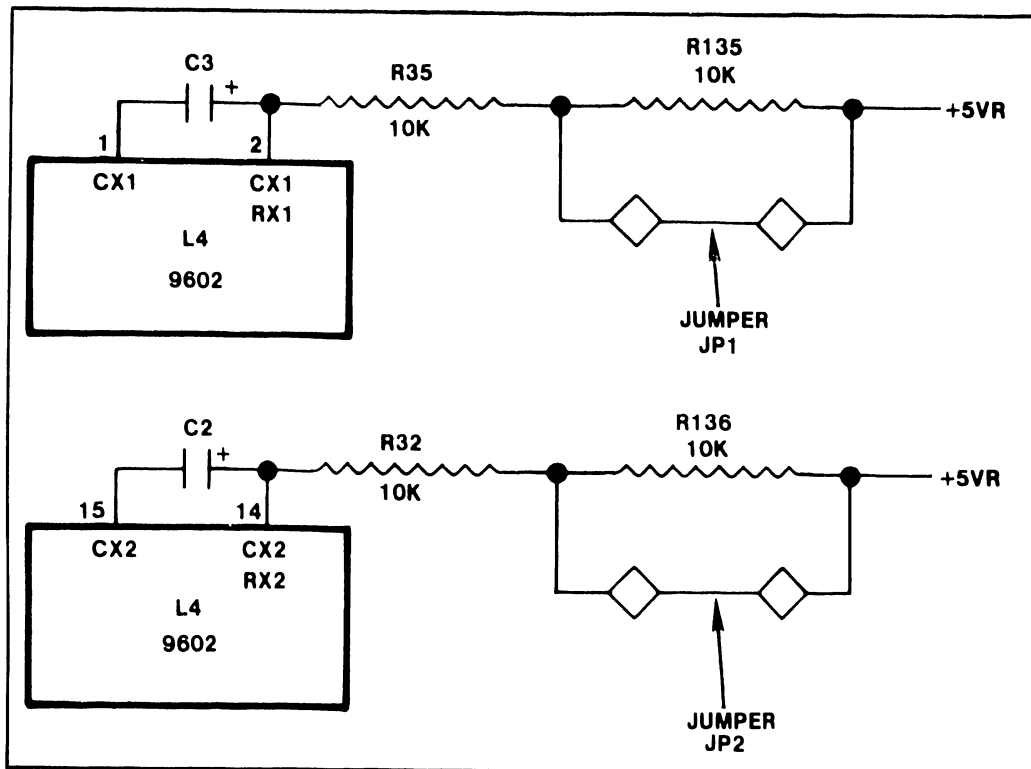

Figure 4-5 Speed Control Jumpers (J1 and J2)
PWR/Driver PCB P/N (210-7594)

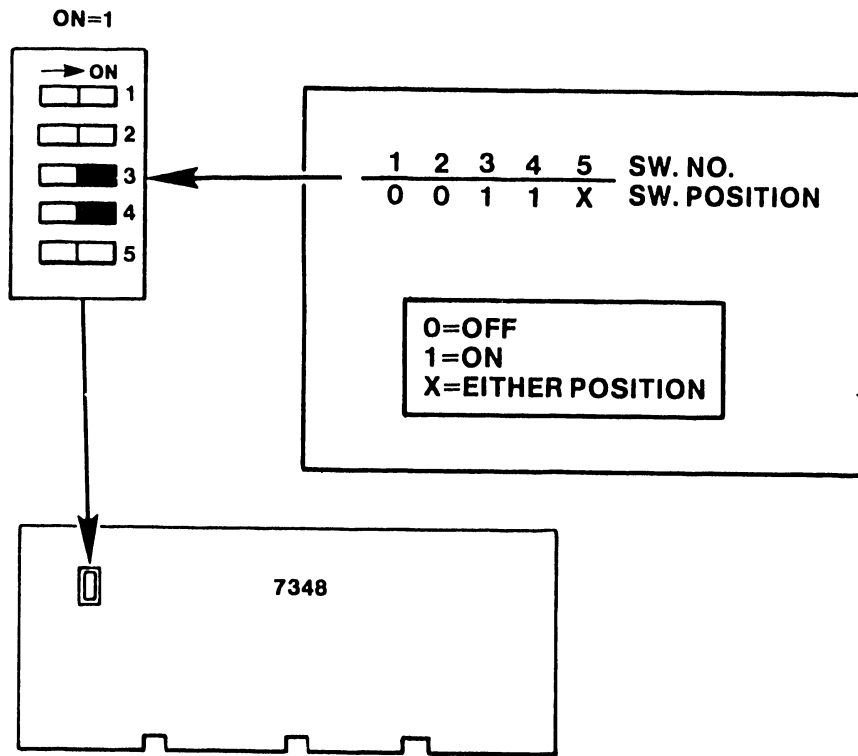

Figure 4-6 PIO CPU PCB P/N 210-7348

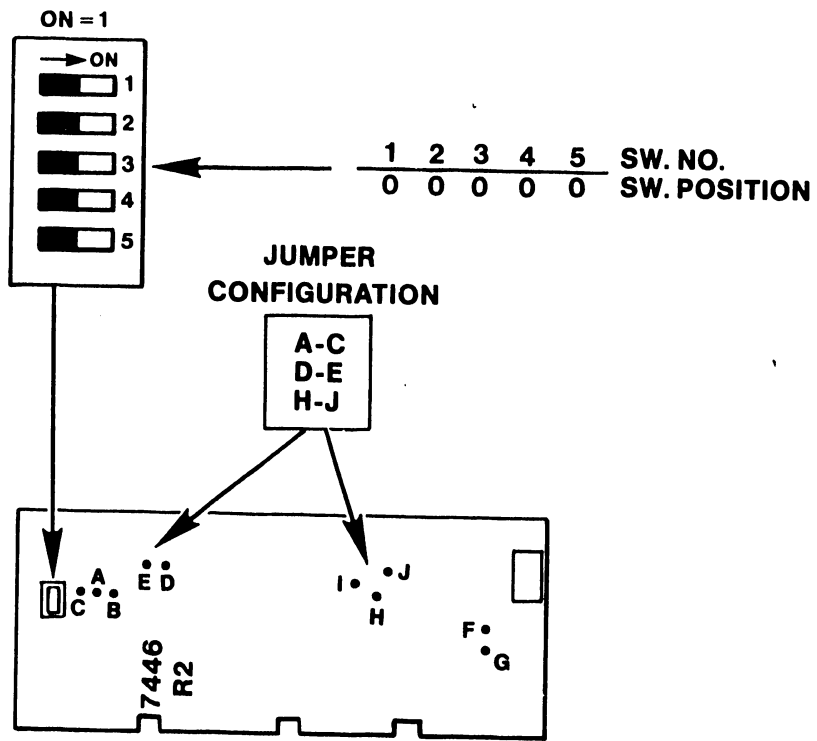

Figure 4-7 Data link PCB Switch and Jumper Settings

4.4 PRINTER POWER-ON PROCEDURE

Perform the following steps to turn printer power on.

1. Set printer power On by pressing the ON side of the power switch. This will illuminate the POWER indicator on the control panel.
2. Set the forms thickness lever for good print quality. Place the lever at a 5 setting for a safe start. The forms thickness can now be adjusted as described in Paragraph 3.7.
3. Select the printer to receive documents by pressing the SELECT switch on the printer control panel. The SELECT indicator located on the switch will illuminate.
4. Verify that the printer is ready for use by printing a customer supplied document or by performing Print Quality Test procedures in Section 4.5.

4.5 PRINTER SELF-TEST

The Matrix Printer Models 2233/2235 and 5533/5535 contain a built-in test that will indicate the cause of failure in the event that the printer fails to operate properly when initially turned on. Four LED indicators located to the right of the control panel are shown in Table 4-1, 4-2 which display a series of binary error codes.

Turn printer ON. A 'beep' tone should sound the moment the printer power is turned ON indicating that the printer is ready. If the tone is not heard, there is a possibility of a printer malfunction. Lift the front cover of the printer and check the four LED error indicators located to the right of the control panel.

4.5.1 Power Up Diagnostic Error Indicators (All Models)

An illuminated MALFUNCTION indicator signals a printer error such as a PROM error or a Vertical Format Unit (VFU) loading error. If the printer stops operating and the MALFUNCTION indicator is ON, attempt to reinitialize the printer by pressing the front panel SELECT switch repeatedly. If the MALFUNCTION indicator remains ON, check the error indicators in the following Tables.

When the Top Cover is opened an error sequence is displayed (1 0 1 1). The VFU error sequence indicates an error in the coding of the Vertical Format that can be corrected by the user. Refer to the Appendix C, Chapter 5 for more detail regarding Direct Access Vertical Format Unit (DAVFU).

Table 4-1
2233/2235 Power-Up Error Indicators

LED Error Codes 8 4 2 1	Error Description
0 0 0 1	Prom Error
0 0 1 0	RAM Address Error
0 0 1 1	RAM Memory Error
0 0 1 0	BIT 6 Not Set in VFU Data (2200 Problem)
0 1 1 0	Too Many VFU Data Bytes Sent
0 1 1 1	Strobe Flip-Flop Does Not Set
1 0 0 0	Strobe Flip-Flop Does Not Reset
1 0 0 1	Prime Flip-Flop Does Not Set
1 0 1 0	Prime Flip-Flop Does Not Reset
1 0 1 1	Cover Open (Close Cover)
1 1 0 0	No Column Strobes
1 1 0 1	Right Sensor Out Of Adjustment

Table 4-2
5533/5535 Power-Up Error Indicators

LED Error Codes 8 4 2 1	Error Description
0 0 0 1	Prom Error
0 0 1 0	RAM Address Error
0 0 1 1	RAM Memory Error
0 1 1 1	Strobe Flip-Flop Does Not Set
1 0 0 0	Strobe Flip-Flop Does Not Reset
1 0 1 1	Cover Open (Close Cover)
1 1 0 0	No Column Strobes
1 1 0 1	Right Sensor Out Of Adjustment

4.6 SWITCH-SELECTED PRINT QUALITY TESTS

The printer contains switch selectable tests for print quality. The Test Switch is located under the cover to the right of the control panel. To access the switch remove two Phillips-Head screws and remove the cover. The switch is shown in Figure 4-8.

The switch settings referenced in the following paragraphs correspond to the markings etched on the keyboard assembly, not the markings on the switch. Refer to Table 4-3 for a summary of the tests. A description of each test follows.

The STROBE switch is initially set to the OFF position. To perform any of the following tests, initially set switches 1, 2 and 4 to the positions indicated. Start the test by setting the STROBE switch to ON. After the test is complete, reset the STROBE switch to the OFF position.

Table 4-3 Print Quality Test Summary

Test	Switch	LED	Error Indicators Condition
	Settings 1 2 4 Strobe	Indicators 8 4 2 1	
LED	0 0 0 1	1 1 1 1	Good
5 Line	1 0 0 1	N/A	
Spiral Pattern	0 1 0 1	N/A	
Data Strobe F/F and Prime F/F	1 1 0 1	1 0 0 0	Data Strobe F/F failed to set. Data Strobe F/F failed to reset.
Carriage Speed	0 0 1 1	1 0 0 0 0 0 0 1 0 1 1 0	Speed too Slow Speed too Fast Correct Speed
Staircase Pattern	1 0 1 1	N/A	
Vertical Bar	0 1 1 1	N/A	
Paper Advance	1 1 1 1	N/A	

LED TEST: Select code 1, 2, 4 OFF (binary 0). All four (4) LED's will light.

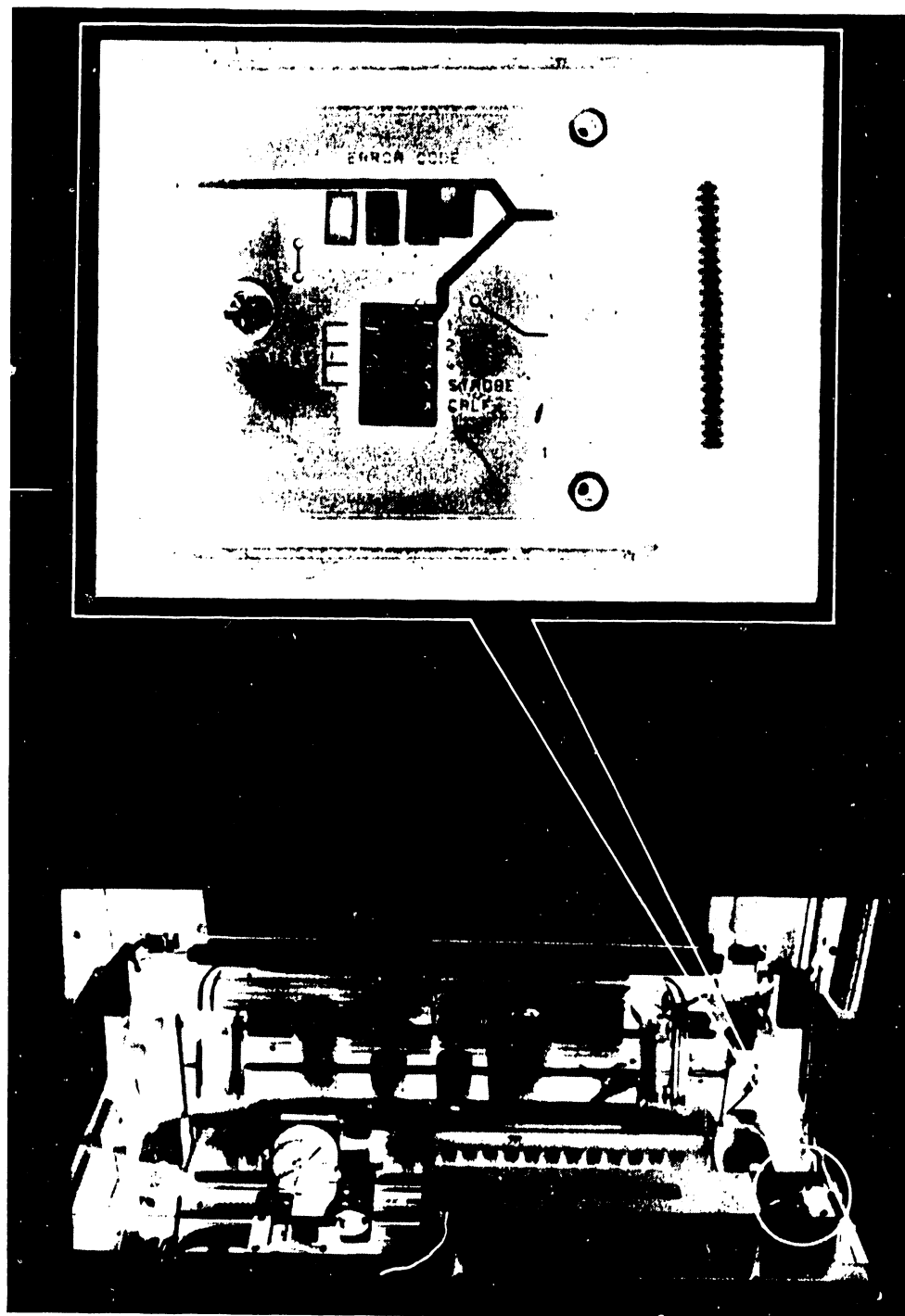

Figure 4-8 Test Switch and Error Indicators

Five line Test - Select (binary 1) code 1 ON, 2 and 4 OFF. Line 1 consists of a row of vertical bars. Line 2 and 3 consist of the words TAB which are printed at the beginning of the lines and the words TEST printed at the end of the lines. Line 4 consists of a full line of underlined ASCII characters and Line 5 prints a staircase pattern testing the firing of each pin in the print matrix. A printout of this test is shown in Figure 4-9.

Spiral Pattern test - Select (binary code 2); switch 2 ON, switch 1 and 4 OFF. This test is designed to check and verify that there is no interaction between the internal print buffer, the data bus and other internal electrical interference associated with the desired print character. The routine prints all the printable characters (except for HEX 20) in a spiral pattern. The printout of this test is shown in Figure 4-10.

Data Strobe F/F and Prime F/F Test - Select (binary code 3), 1 and 2 ON, 4 OFF. If the data strobe Flip-Flop fails to set, binary 8 will be displayed on the LEDs above the switches. If the Flip-Flop fails to reset, binary 9 will be displayed. If the test passes a binary coded three will be displayed via the front control panel LEDs.

Carriage Speed Test - Select (binary code 4) switches 1 and 2 OFF, 4 ON. The LEDs will display the carriage speed as shown in Table 4-3.

If the carriage speed is too slow or too fast, perform the adjustment described in Paragraph 5.3.18.

Staircase Pattern Test - Select (binary code 5) switches 1 and 4 ON, 2 OFF. This test verifies that each of the nine printer pins are firing correctly. A staircase pattern of dashes (-) is printed with a vertical line at each end. The printout of this test is shown in Figure 4-11.

Vertical Bar Test: Select (binary code 6) switches 2 and 4 ON. This test will determine if the right sensor adjustment is correct. If the right side vertical row of bars do not appear to be in a straight line (some are shifted to the right or left), the right sensor should be checked as described in Paragraph 5.3.19, 5.3.20. The printout of this test is shown in Figure 4-13.

Paper Advance Test: Select (binary code 7) switches 1, 2, 4 ON. The paper will advance repeatedly, one line at a time.

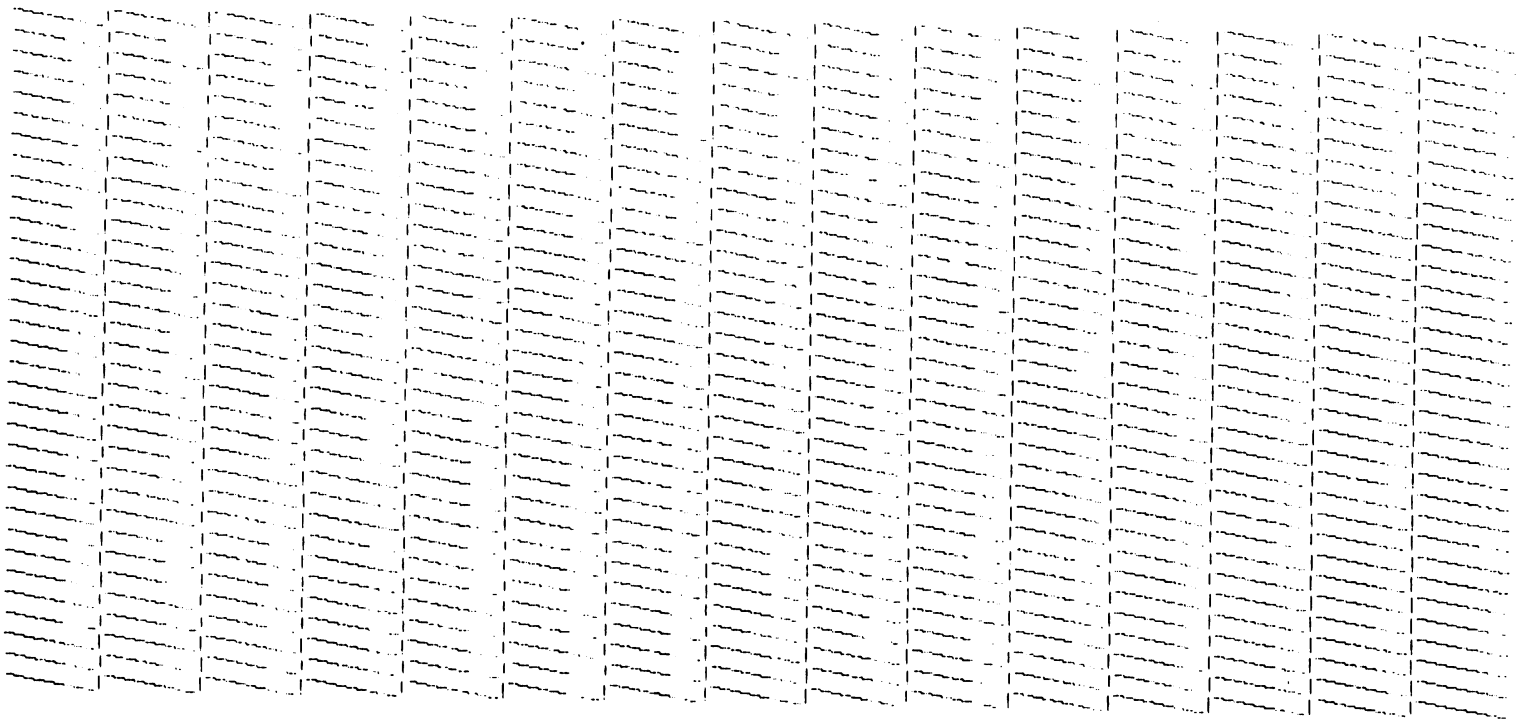

Figure 4-11 Staircase Pattern Test

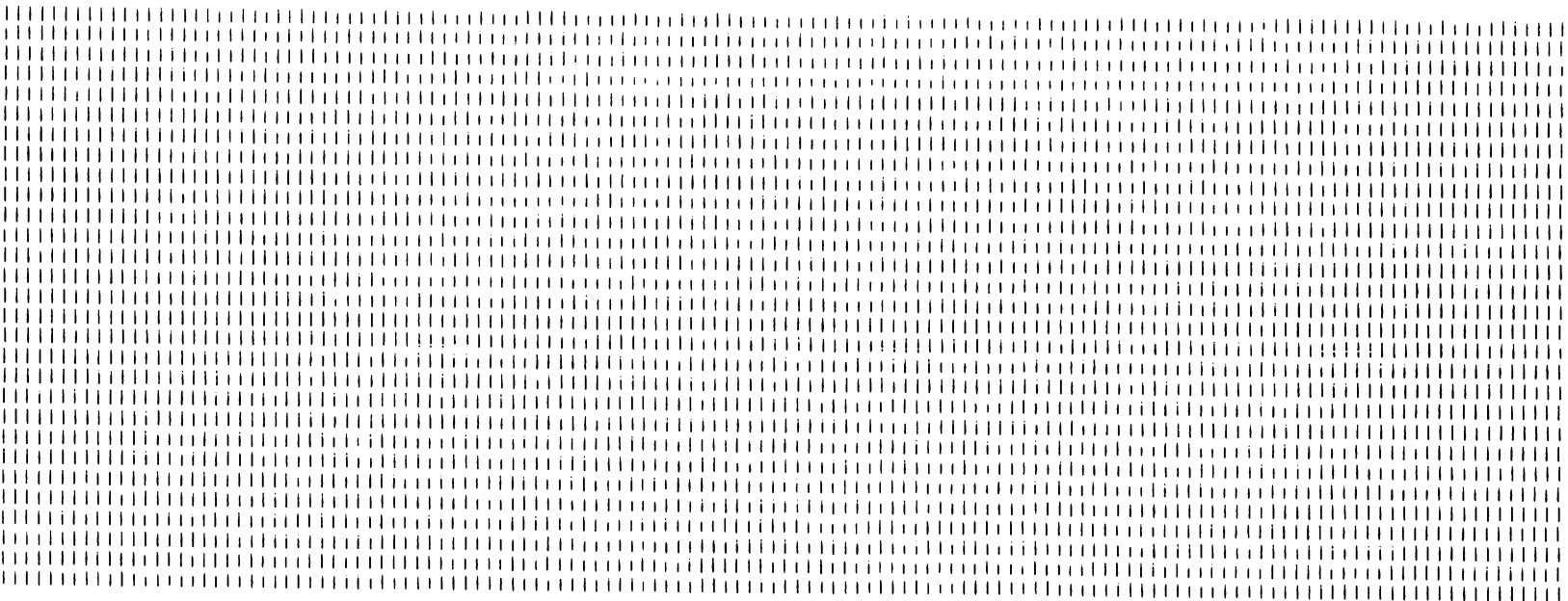

Figure 4-12 Vertical Bar Test

4.7 2233/2235 PRINTER DIAGNOSTICS (2200 Systems)

The printer diagnostic (P/N 702-0145) tests all print functions (including pitch, font and special features), internal software and all mechanical control features.

This diagnostic has no error indication capabilities. All errors must be detected by the operator who must visually inspect the copy of the printout and compare with the sample provided. Refer to Appendix B for a description of the diagnostic tests.

4.7.1 Diagnostic Load Procedure

1. Insert the diagnostic floppy diskette. Insure the correct disk drive is selected.
2. To load the diagnostic, type "LOAD RUN".
3. Press 'Return/Execute'. The printer should be loaded with two-tone paper. The TOP OF FORM starts at the second color (one-half inch from the top). Ensure that the printer is selected.

4.7.2 Operating Instructions

All menu selections that appear on the screen will have numbers (starting at 0) to represent the options. On all but the first menu, the operator can select the 0 option by depressing 'Return/Execute'. It is not necessary to key in '0'.

The first menu asks for the master disk address. This is the drive that has the diagnostic diskette. The other menus appear in order as seen below:

MENU 2
Type of test (0 = Confidence Test)
 (1 = QA Acceptance)

MENU 3
Pitch (0 = 10)
 (1 = 12.2)

MENU 4
Lines Per Inch (0 = 6)
 (1 = 8)

MENU 5

Automatic Line Feed (0 = Yes)
 (1 = No)

MENU 6

- 1) All tests
- 2) Tests 5 and 6 only
- 3) Tests 1-17
- 4) Tests 1-21
- 5) Selectability

If #1 is selected, the diagnostic will run all the tests in this order:

Tests 5 and 6; Tests 1-21; Tests 1-17; Tests 5 and 6; Tests 1-17. The reason for rerunning the tests is that 3 different VFU's will be loaded (indicated by '*'). The operator will be able to recognize the changes, especially in Test 5.

If 'Selectability' is chosen, the operator is given another option:

MENU 7

Loop on Routine (0 = No)
 (1 = Yes)

Then, another menu is displayed listing all the tests:

MENU 8

- | | |
|----------------------------|---------------------------------------|
| 1. Data Buffer Test | 11. Pin Firing Test |
| 2. Spiral Pattern Test | 12. Pitch Test |
| 3. Character Set Test | 13. Quarter Line Feed Down Test |
| 4. Line Feed Test | 14. Line Feed Down Test |
| 5. Vertical Tab Test | 15. Variable Vertical Spacing Test |
| 6. End of Document Test | 16. Line Feed Override & Underscoring |
| 7. Skip Channel Test | 17. Expanded Pitch Test |
| 8. Skip Line Test | 18. Lines Per Minute Test |
| 9. Carriage Return Test | 19. Select/Deselect & Audio Alarm |
| 10. Print Consistency Test | 20. Operator Clear Test |
| | 21. Paper Out & Forms Override Test |

When the tests are completed, another menu will be displayed asking the operator if any option changes are wanted for the next run of tests.

MENU 9

Configuration Change (0 = No)
 (1 = Yes)

If Loop on Routine is not selected, the diagnostic will run the selected test and all subsequent tests.

Tests 18-21 require operator intervention. The Line Per Minute Test requires that the operator obtain a timing device with a second hand. When the printer begins, time it for one minute, then stop the test.

Test 19 (Select/Deselect & Audio Alarm Test) will print the line "OPERATOR MUST SELECT & DESELECT THIS PRINTER AT LEAST FIVE TIMES". After each line is printed, the printer audio alarm will sound and an additional line feed is issued. The operator should select and deselect at least five times.

The Operator Clear Test (Test 20) requires that the operator deselect the printer, depress 'Clear', and reselect the printer. If the clear function is not working, the operator will see "E R R O R - I N OPERATOR CLEAR FIRST". If the clear function is working, the operator will see "OPERATOR CLEAR FIRST".

Test 21 (Paper Out & Forms Override Test) asks the operator to tear the paper at the next perforation that would enter the printer. Next, the operator must deselect the printer, then depress "Line Feed" until the "Forms Override" light illuminates. Then, reselect the printer, depress "Return/Exec" on the CRT, and depress "Forms Override" THREE times on the printer.

If option 1 (All Tests) is selected, the operator must reload the paper and set up the Top-Of-Form after Test 21 is finished. A message will be displayed on the CRT and the audio alarm will be sounded.

Each time there is operator intervention, the 2200 CRT will display the operating instructions and sound the CRT audio alarm. When the operator has read the instructions, "Return/Exec" must be depressed to begin the test. To exit the Lines Per Minute Test and the Select/Deselect & Audio Alarm Test, the operator must also depress "Return/Exec".

If the operator should interrupt the test and want to retest the printer, Special Function Key (31) must be depressed. This will start the program over as if the initial load procedure had taken place.

When the printer test ends, the operator will be asked if any configuration changes are needed (Menu 9). If the operator responds "No", the tests will rerun with the same options and same tests. If "Yes" is selected, Menu 2 will be displayed and the operator can change the options.

4.8 DIAGNOSTIC PRINTER MODELS 5533/5535

Model 5533/5535 Printer Diagnostics are used to test all printing functions, internal software and all mechanically controlled features.

This diagnostic has no error indication capabilities. All errors must be detected by the operator who must visually inspect the copy of the printout and compare with the sample provided. Refer to Appendix B for a description of the diagnostic tests.

NOTE: The following information is based on diagnostic software release Rev. 10C0 and documentation release Rev. 9C0.

4.8.1 Load Procedure

1. Insert the floppy disk (core image file) into the disk drive and depress the I-L button.
2. A message reading "IS THIS THE TDC CONSOLE" should be displayed. Depress "Execute" and all the peripherals connected to the Master CPU will be displayed on the TDC (Test Display Console) workstation.
3. Select either 5533 or 5535 printer which will load the diagnostic. For further information, refer to the Monitor documentation.

4.8.2 Operating Instructions

Only four menus are involved with this diagnostic. The menus displayed are:

MENU 1

Type of Test	0 = Confidence Test
	1 = QA Acceptance

If the operator wants to select the Confidence Test (short version), the number '0' does not have to be typed in. By depressing 'Execute' on the TDC (Test Display Console), the test will default to the 0 option.

MENU 2

Do you want to select tests individually (Y or N)

For this option, the letter 'N' or 'Y' must be typed in for operation to continue. If 'N' is selected, the program will load the first test and run all the tests in order. If 'Y' is selected, another menu will be displayed giving the operator the option of selecting any of the thirteen (13) tests.

MENU 3

- | | |
|--------------------|------------------------------------|
| 1. Data Buffer | 7. Carriage Return |
| 2. Spiral Pattern | 8. Print Consistency |
| 3. Character Set | 9. Pin Firing |
| 4. Line Feed | A. Line Feed Override & Underscore |
| 5. Vertical Tab | B. Expanded 10 Pitch |
| 6. End of Document | C. Lines Per Minute |
| | D. Select/Deselect & Audio Alarm |

The program will run the test selected and all subsequent tests unless loop on routine has been selected.

NOTE: For Tests 10-13, letters must be typed in instead of the number

Tests C and D require operator intervention. The Lines Per Minute Test requires that the operator obtain a timing device that is capable of timing seconds. When the operator is ready to begin timing, select the printer. After 60 seconds, deselect the printer. To continue to the next text, the printer must be selected again. Test D (Select/Deselect & Audio Alarm Test) will print the line "OPERATOR MUST SELECT & DESELECT THIS PRINTER AT LEAST FIVE TIMES". After each line is printed, the printer audio alarm will sound. The operator must select and deselect the printer at least five times or else an error message will be printed (after 30 lines of print).

When the last test has finished, another option will be displayed:

MENU 4

Does the next print sample require a configuration change?
(0 = No) (1 = Yes)

If the operator wants to change test types, type '1'. The first menu will be displayed again. If no changes are desired, hit 'Execute'. Regardless of whether a change is wanted or not, the option of selecting individual tests will be displayed again.

4.9 MISCELLANEOUS

Through the use of the Monitor, features such as:- (1) Halt testing, (2) Loop on test routine and (3) Count loops can be implemented. For further information on how to operate the Monitor, refer to the operational system manual. The Test Display Console (TDC) workstation is utilized to display all the status codes, messages and input controls necessary to operate this diagnostic.

The Model 5533/5535 printers have been designated as a TYPE 306. Before operation starts, the diagnostic checks to insure that the printer being tested is a TYPE 306. If it is not, a message will be displayed on the screen indicating that the printer is of the wrong type.

4.10 PRINTER SIGNAL CABLES

The signal cable P/N (220-0105-1) is supplied with Models 2233/2235. Attach the cable end with locking screws to the 36-pin rear panel printer connector and the other end to the printer controller board in WANG 2200/2200VP, 2200 LVP, 2200 MVP, 2200 SVP systems. The printer may be located a maximum of 50 ft. from the system.

The signal cable P/N (220-0148) is supplied with the Models 5533/5535. This is a twin coaxial cable having BNC and TNC connectors that attach to the corresponding connectors on the printer rear panel (shown in Figure 2-6). Connect the other end of the signal cable to the WANG OIS/WP or VS System Master rear I/O panel. Other cable lengths are available for convenience of printer location. Each cable length exceeding 25' has a different part number. The printer may be located a maximum of 50 ft. from the system.

4.11 POWER SOURCE 115/230 VAC CONVERSION

To convert matrix printer Models 2233/2235/5533/5535 to/from 115Vac or 230Vac operation, perform the following procedure.

1. Set printer power switch to OFF position.
2. Remove the top cover of the printer, using the instructions in Section 2.4, steps a,b,c,d. Locate the voltage selector plug mounted next to the input power panel.
3. To change from one operating voltage to the other, remove the existing plug from the connector and install the other plug. See Figures 4-3.
4. Change the power fuse located on the rear panel. Part numbers and fuse ratings are listed below.

115 Vac OPERATION	3.0 AMP (SB)	WL# 360-1031-SB
230 Vac OPERATION	1.5 AMP (SB)	WL# 360-1016-SB

4.12 PAPER RACK INSTALLATION

A paper rack P/N (458-1053) is furnished as standard equipment with all matrix printer models. The paper rack is packed in the shipping carton.

1. The paper rack can be installed without removing the top cover. However, while performing preliminary checks during installation, the paper rack can be attached to the removed top cover.
2. Slide the front (clip edge) of the paper rack in the direction of the arrows until it is seated securely over the front edge of the rear section of the cover.
3. Press the rear of the paper rack down under the back of the rear cover in the direction of the arrows until it snaps into place under the rear cover.
4. Loosen the 8-32 screw with the No. 8 flat washer on the outside end of the hex shaped standoff.

NOTE: Check for sufficient clearance between the upper paper pan and the lower front edge of the paper rack to be sure that the two surfaces do not bind when reinstalling the cover assembly. If the surfaces bind, perform step 5 before attempting to secure the cover to the printer.

5. Loosen the four screws and adjust upper paper pan for adequate clearance between the pan and the paper rack. Tighten the four screws.
6. Reinstall the cover assembly on the printer.
7. Secure the crimped edge at the rear of the paper rack to the hex standoff with the screw and washer. Tighten screw.

CHAPTER

5

PREVENTIVE AND CORRECTIVE MAINTENANCE

CHAPTER 5
PREVENTIVE AND CORRECTIVE
MAINTENANCE

5.1 INTRODUCTION

Chapter 5 provides information necessary to adjust and to remove and replace mechanical assemblies of the Dot Matrix Printer Models 2233/2235 5533/5535. The following procedures incorporate the latest changes that affect the printers as of the release date of this manual. Perform the adjustments in the order presented.

5.2 TOOLS REQUIRED

Part No.	Description
726-9487	Feeler Gauge Set
726-9407	Medium Phillips Screwdriver
726-9405	Small Phillips Screwdriver
726-9457	3/16" Allen Wrench
726-9444	9-64" Allen Wrench
726-9485	Rule 6", Metal
726-9491	Inspection Mirror
726-9596	Digital Volt-Meter (DVM)
726-9501	Flashlight, Pocket

5.3 CHECKS AND ADJUSTMENTS

5.3.1 Print Head Retraction Lever Check

- a. Set forms thickness lever to detent position 5. This is the mid-point of lever travel. At position 5 the lever is pointing directly upward.
- b. Set the print head retraction lever so that the set screw on the carriage shaft is facing directly upward as shown in Figure 5-1.
- c. Note the position of the retraction lever. It should also be facing directly upward. If it is not, perform the adjustment in Paragraph 5.3.2.

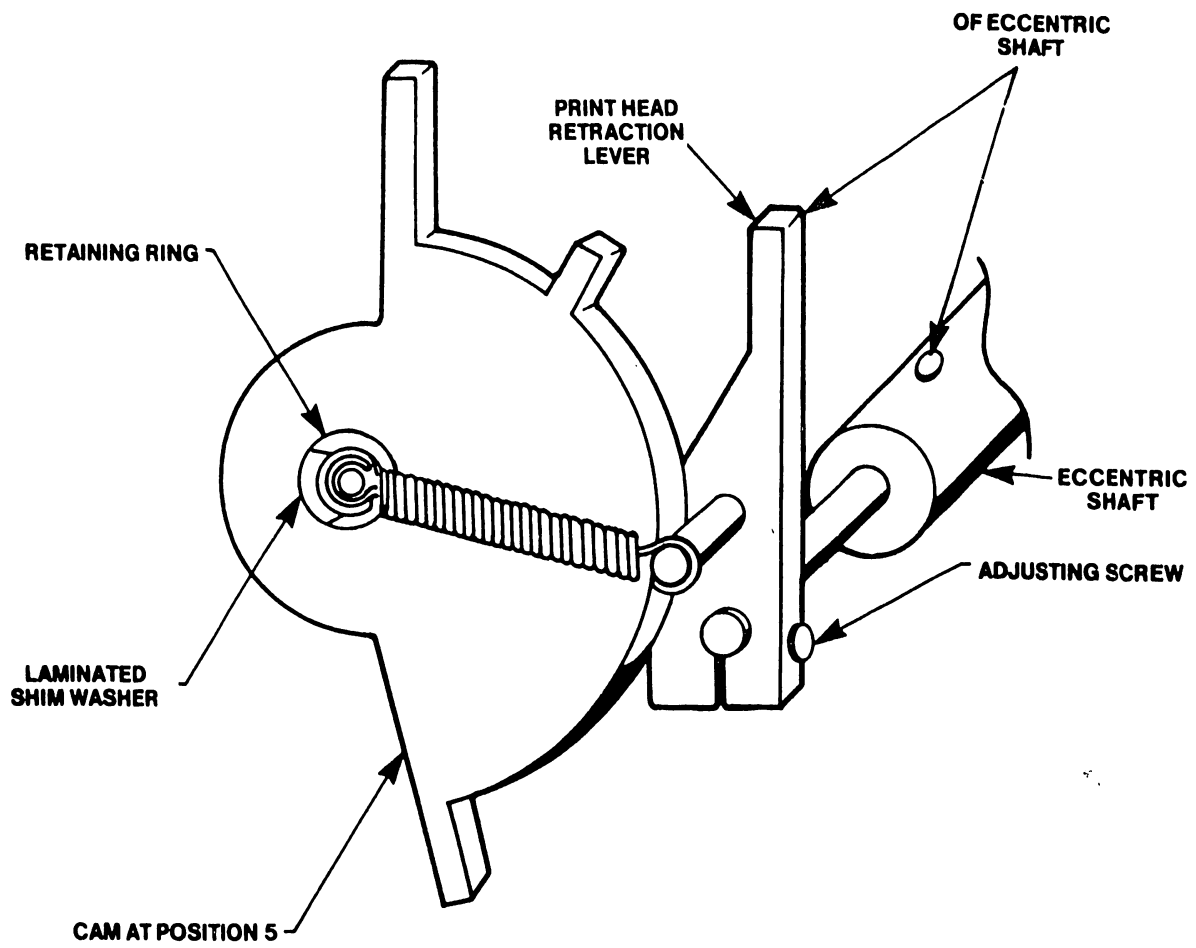

Figure 5-1 Retraction Lever

5.3.2 Print Head Retraction Lever Adjustment

- a. Set forms thickness lever to detent position 5. This is the mid-point of lever travel. At position 5 the lever is pointing directly upward.
- b. Set the print head retraction lever so that the set screw on the carriage shaft is facing directly upward as shown in Figure 5-1. Use an Allen wrench as a lever to hold shaft and maintain the straight up position of the Allen screw.
- c. Using an offset Phillips screwdriver, loosen the set screw on the print head retraction lever.
- d. While holding the carriage shaft to prevent it from rotating, move the lever so that is facing directly upward. Tighten the retraction lever set screw.

5.3.3 Matrix Print Head To Striker Bar Clearance Check

- a. Clean the front edge of the striker bar shown in Figure 5-2.
- b. Set the forms thickness lever shown in Figure 5-2 to position 1.
- c. Move the print carriage manually to the left side of the printer.
- d. Using a feeler guage, check the clearance between the print head and the striker bar. It should be $0.018" \pm 0.001"$ ($0.46\text{mm} \pm 0.03\text{mm}$).
- e. Move the print carriage to the right side of the printer and perform the same measurement as in step d.
- f. If the clearance measured in step d. or step e. is not within the specification, perform the adjustment as outlined in Paragraph 5.3.4.

5.3.4 Matrix Print Head To Striker Bar Adjustment

- a. Clean the front face of the striker bar.
- b. Set the forms thickness lever, shown in Figure 5-2 to position 1.
- c. Using a $9/64"$ Allen wrench, loosen the two cap screws located at each end of the striker bar. See Figure 5-2 for screw location. Also loosen the three screws located on the top of the striker bar.
- d. Move the print carriage to the left side of the printer.
- e. Place an $0.18"$ feeler gauge between the front surface of the print head and the striker bar. Move the striker bar slightly as required, for an accurate clearance of $0.018" \pm 0.001"$ ($0.46\text{mm} \pm 0.03\text{mm}$).

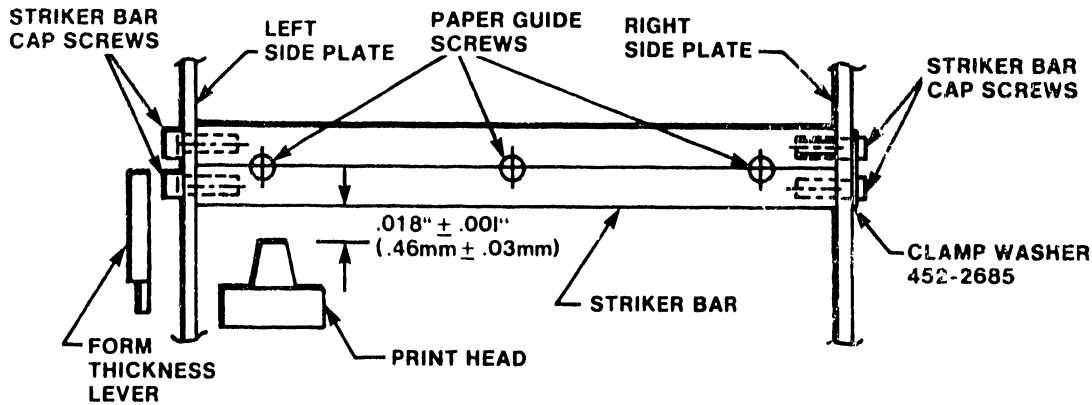

Figure 5-2 Print Head to Striker Bar Clearance

- f. Move the print head carriage to the right side of the printer, and perform the same adjustment in step e. Recheck the adjustments by moving the carriage back and forth.
- g. Using the $9/64''$ Allen key wrench, tighten the two screws at each end of the striker bar. Retighten the three screws on the top of the striker bar. Recheck the clearance with the head carriage at the left side of the printer, then at the right side. If damage occurs to the front edge of the striker bar turn the bar over as the bar is reversible.

5.3.5 Ribbon Guide Shield Adjustment and Carriage Notch Check

- a. Loosen two guide adjustment screws and adjust the ribbon guide for $.017''$ gap from the striker bar as shown in Figure 5-3.

NOTE: For printers with a notch on the carriage housing verify that the notch is $1/4''$ and not $1/8''$ as shown in Figure 5-3A. If the notch measures $1/8''$ perform the following steps.

- b. Perform the Print Head Carriage Assembly Removal procedure Paragraph 5.5.8.
- c. Using a metal file increase the notch to $1/4''$ as shown in Figure 5-3A.
- d. Install the Head Carriage Assembly per Paragraph 5.5.9.

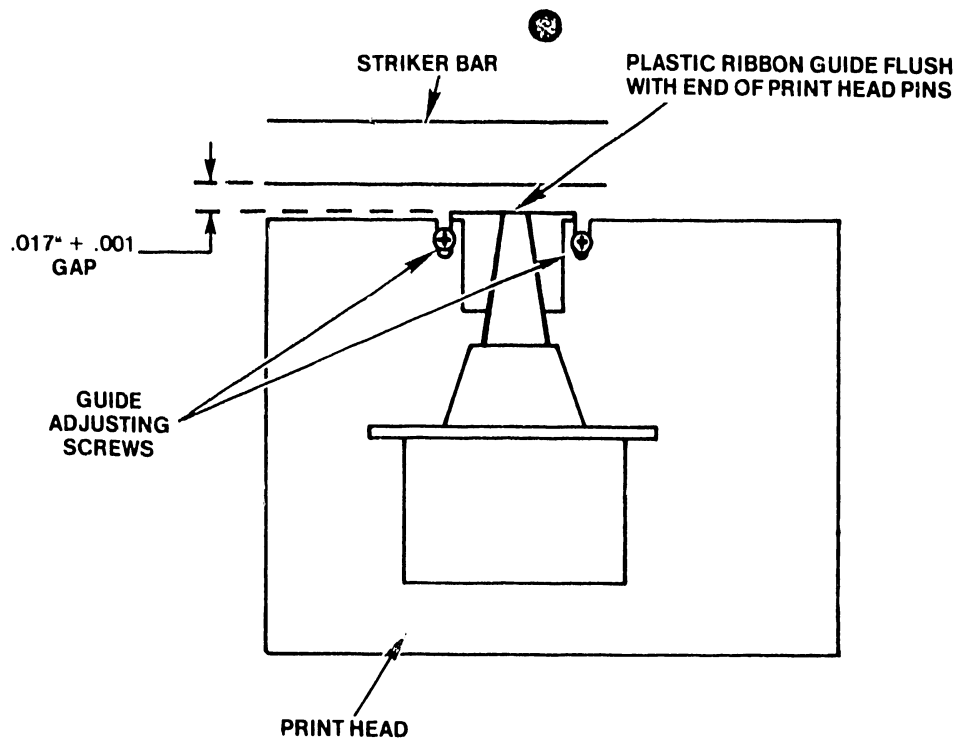

Figure 5-3 Ribbon Guide Shield Adjustment

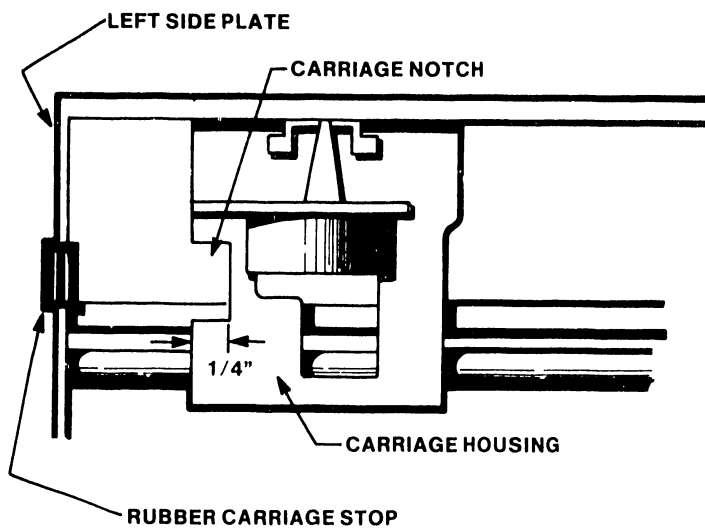

Figure 5-3A Carriage Notch

5.3.6 Striker Bar To Paper Guide Clearance Check

- a. Using a feeler gauge, check the distance between the front of the striker bar and the paper guide, as shown in Figure 5-4. The distance from the front of the striker bar to the front of the guide should be from 0.020" to 0.050" (0.5mm to 1.3mm), when measured at the left and right ends of the striker bar.
- b. If the measured distance is outside of these limits, perform the adjustment in Paragraph 5.3.7.

5.3.7 Striker Bar To Paper Guide Clearance Adjustment

- a. Using a screwdriver, loosen the three screws located on the top of the striker bar. See Figure 5-4, for screw location. Also loosen the three screws that fasten the paper guide to the baseplate.
- b. Using a feeler gauge to measure the distance from the front of the striker bar to the front of the paper guide; adjust the guide in or out until the distance is in the range of 0.020" to 0.050" (0.5mm to 1.3mm), as shown in Figure 5-4.
- c. Tighten the three screws on the top of the striker bar and the three screws that fasten the guide to the baseplate. Recheck the adjustment.

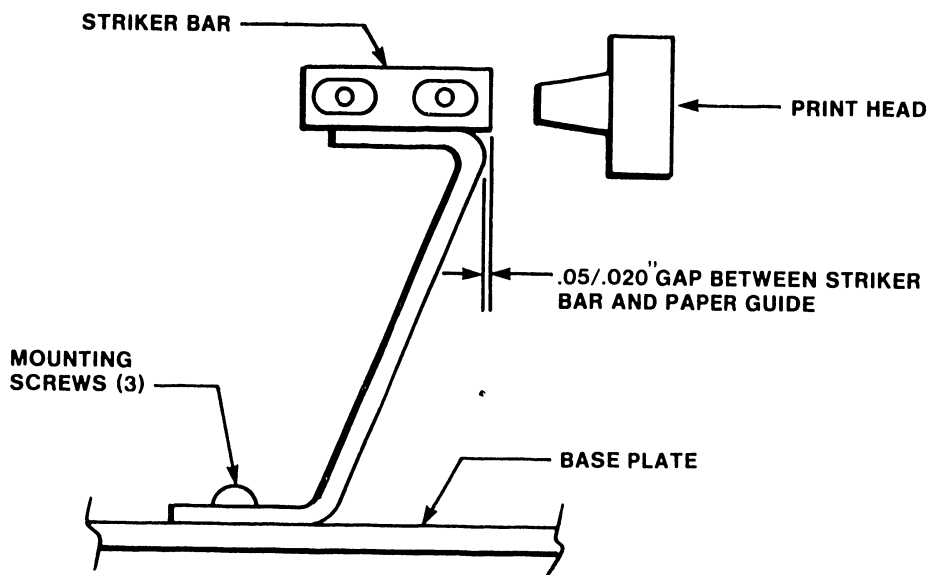

Figure 5-4 Striker Bar To Paper Guide Clearance Check

5.3.8 Paper Drive Belt Tension Check

- a. Move the head carriage to the right side of the printer.
- b. Using a spring gauge and scale, deflect the middle of the belt $1/8''$ (3.2mm). See Figure 5-5. The gauge should read 8 oz. \pm 2 oz. If the measurement is not within specifications, perform the adjustment in Paragraph 5.3.9.

5.3.9 Paper Drive Belt Adjustment

- a. Using a screwdriver, slightly loosen the three motor mounting screws shown in Figure 5-5.
- b. Shift the motor assembly to obtain the belt tension specified in Paragraph (5-8), step b.
- c. Retighten the motor mounting screws and recheck the belt tension.

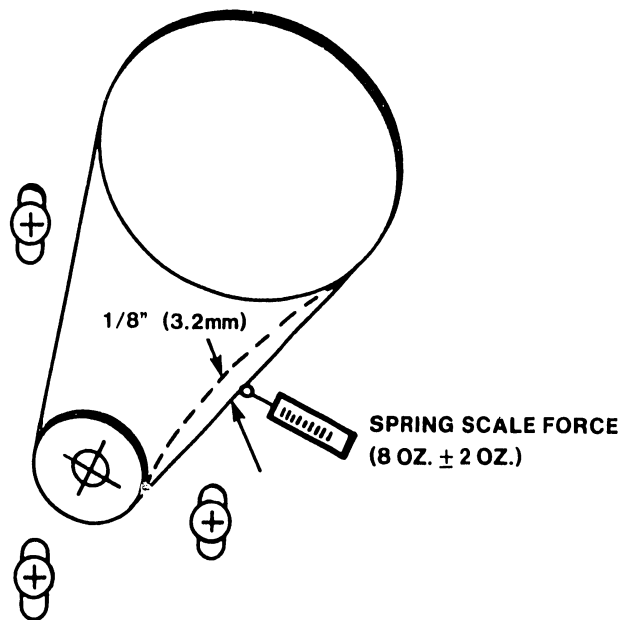

Figure 5-5 Paper Drive Belt Tension

5.3.10 Carriage Belt Tension Check

- a. Move the head carriage to the right side of the printer.
- b. Using a spring gauge, press the center of the drive belt downward using a force of 16 oz. \pm 2 oz. See Figure 5-5.
- c. Using a 6" scale, measure the distance that the belt is deflected downward by the force applied in step b. The deflection should be 0.33" (8.4mm \pm 0.8mm). If it is not within the stated values, perform the belt tension adjustment in Paragraph 5.3.11.

5.3.11 Carriage Belt Tension Adjustment

- a. Move the head carriage to the right side of the printer.
- b. Connect a 3/16" offset Allen wrench to the belt adjusting screw shown in Figure 5-6.
- c. Using a spring gauge, press the center of the drive belt downward using a force of 16 oz. \pm 2 oz. Using the Allen wrench, turn the adjusting screw until the belt deflection is 0.33" \pm 0.03" (8.4mm \pm 0.8mm).

5.3.12 Left Hand Margin Sensor Check

Certify that the left margin sensor is adjusted for a full 132 column line. Check the position of the sensor and margin as described.

- a. Move the print head carriage to the right side of the printer.
- b. Using a 6" metal scale, measure the distance from the inside of the left side plate to the right side of the left sensor as shown in Figure 5-7.
- c. The measured distance should be approximately 1-29/32" \pm .03" (1.90") (48.26mm). If it is not set to the specified limit, perform the adjustment in Paragraph 5.3.15.

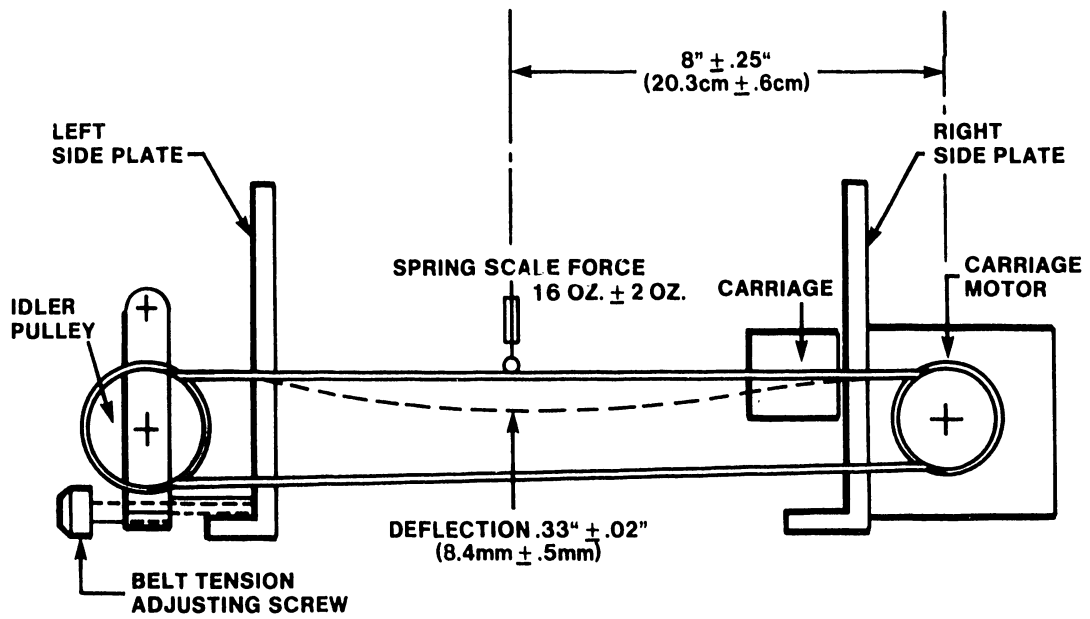

Figure 5-6 Carriage Belt Tension

5.3.13 Left Hand Sensor Margin Alignment

- a. Using a Phillips screwdriver, loosen the two screws that fasten the left sensor mounting bracket to the bottom plate. See Figure 5-7 for sensor location.
- b. Adjust the right edge of the carriage home sensor to the inside of the left side plate. The measurement will be 1.90" (48.26mm).
- c. Tighten the two mounting screws.
- d. The carriage flag plate (under the carriage housing) must be positioned $.12" + .03"$ (approx. $1/8"$) from the right side of the carriage home sensor as illustrated in Figure 5-7. To make this adjustment and measure the results, remove the print head and bracket assembly. Place the inspection mirror in back of the drive belt in front of rear carriage support shaft. View the adjustment through cutout in carriage base plate.
- e. Once this adjustment is correct, the index slot on the encoder must line up with the index sensor as shown. The index sensor is located on the end of the carriage drive motor. The index sensor is the longer sensor. Refer to Paragraphs 5-18 and 5-19.

5.3.14 Right Sensor Check

- a. Using a Phillips screwdriver, loosen the two screws that fasten the right sensor mounting bracket to the bottom plate. See Figure 5-7 for sensor location.
- b. Adjust the right edge of the right sensor for 1.35" to the side frame.

VIEW FROM FRONT OF MACHINE

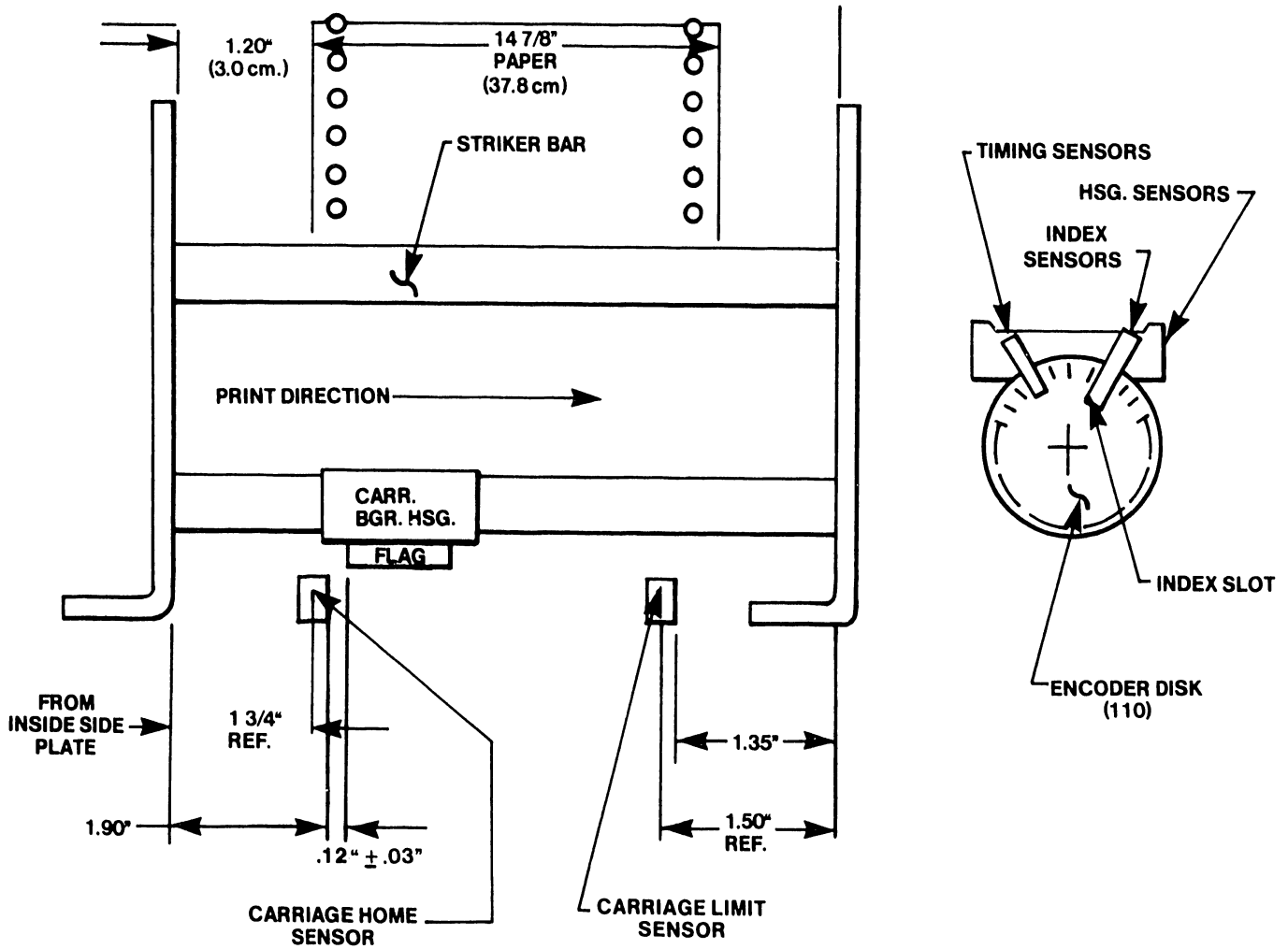

Figure 5-7 Left and Right Sensor Settings

5.3.15 Encoder Disk Check

- a. Unplug the cable at the top of the encoder cover shown in Figure 5-8.
- b. Using a medium-blade Phillips screwdriver, remove the screws that fasten the encoder disk cover and remove the cover.
- c. Position the left edge of the flag under the print head carriage assembly for a close tolerance of $.12" \pm .03"$ ($3.04\text{mm} \pm .76\text{mm}$) from the right edge of the left sensor as illustrated in Figure 5-7.
- d. Using a mirror, view the rear surface of the encoder disk shown in Figure 5-9A. The index mark (the long slit on the disk edge) should be on the center line of the index sensor $+ 1/32"$ (0.8mm) from the centerline of the index sensor, as illustrated in Figure 5-9B. The index sensor is the long sensor.
- e. If the index mark is correctly centered, replace the shield cover on the encoder disk and reconnect the cable to the encoder.
- f. If the index mark is not correctly centered, perform the adjustment in Paragraph 5.3.16.

5.3.16 Encoder Disk Alignment

- a. Unplug the cable at the top of the encoder cover illustrated in Figure 5-8.
- b. Using a number 2 Phillips screwdriver, remove the screws that fasten the encoder disk cover. Remove the cover.
- c. Using a 3-32" Allen key, loosen the setscrew on the encoder shaft Figure 5-9C.
- d. Position the head carriage so that the left edge of the flag under the head carriage is $.12" \pm .03"$ (3.04mm) from the right edge of the home sensor as illustrated in Figure 5-9.

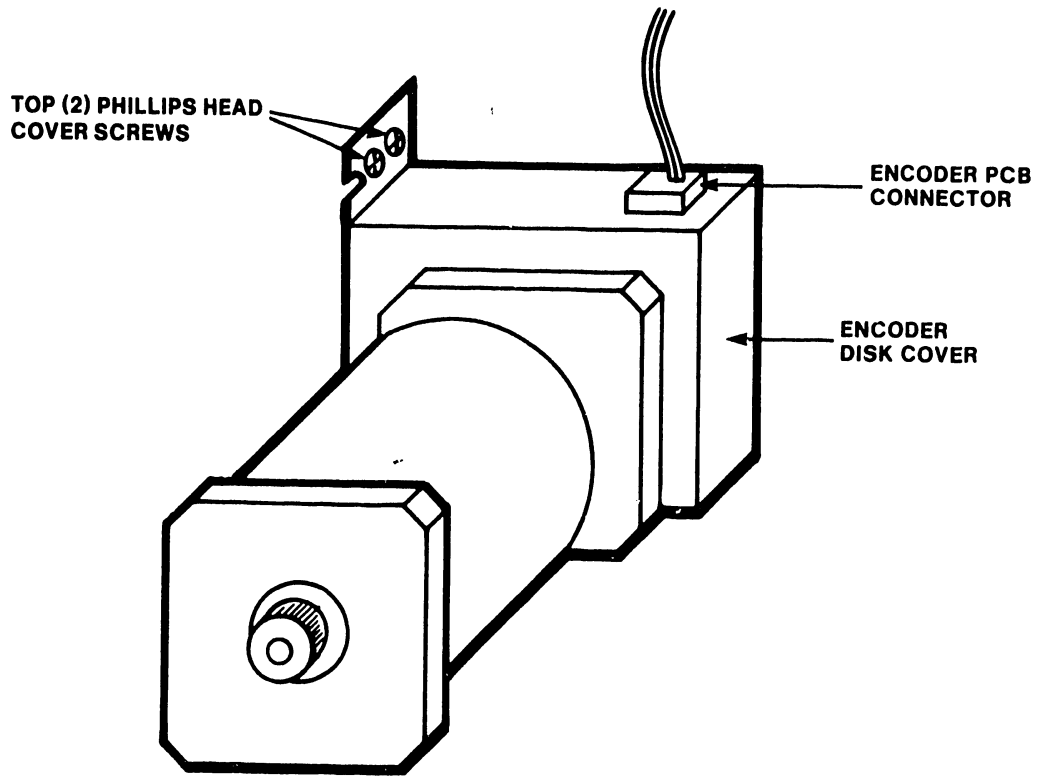

Figure 5-8 Encoder Disk Removal

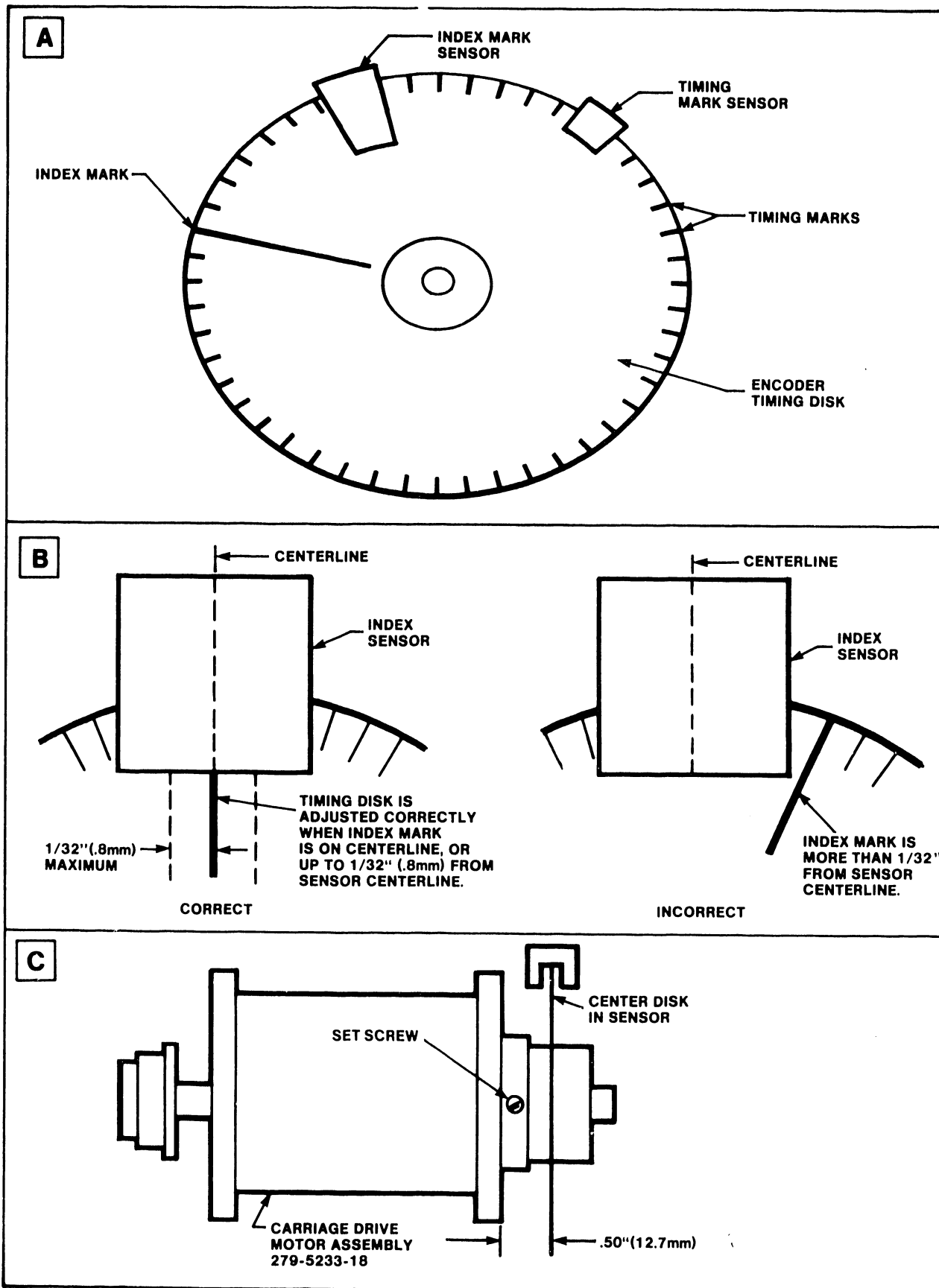

Figure 5-9 Encoder Disk

- e. Using a mirror, view the rear surface of the encoder disk shown in Figure 5-9A. The index mark (the long slit on the disk edge) should be on the center of the index sensor + $1/32$ " (0.8mm) from the centerline of the index sensor as shown in Figure 5-9B.
- f. While holding the front pulley of the carriage drive motor to prevent it from rotating, rotate the encoder disk to center the index mark under the index sensor as shown in Figure 5-9B.
- g. Position the disk in or out, if necessary, to approximately center the disk in the opening of the index sensor Figure 5-9C, then retighten the setscrew on the encoder shaft.
- h. Repeat steps c, d, e, f of the Encoder Disk Check procedure Paragraph 5.3.18.
- i. Replace the disk cover and replace the encoder connector.

5.3.17 Power Supply Voltage Checks

- a. Remove the printer top cover. See Paragraph 4.3, steps 1-5 for cover removal procedure.
- b. Set printer power switch to ON.
- c. Connect a DVM + lead to TP4, the +5 volt test point located on the top edge of the Driver/PS Regulator PCB P/N (210-7594). See Figure 5-10 for Test Point location. Connect the DVM - lead to TP6 (± 0V), located at the top left edge of the PCB.
- d. The voltage should be $5V \pm .1V$. If necessary, adjust the +5V potentiometer (R131) shown in Figure 5-10.
- e. Check for the presence of the following power supply voltages (non-adjustable). The test points are illustrated in Figure 5-10.

TP2 +12V
TP3 -5V
TP5 -12V

5.3.18 Speed Check and Adjustment

- a. Unscrew and remove the switch cover plate located to the right of the front panel control switches.
- b. Set the test switches as follows:
- c. The LED's above the switches (may be blinking) will indicate the carriage speed, as follows:

X 0 0 0	Speed too slow	X = LED lighted
0 0 0 X	Speed too fast	0 = LED not lighted
0 X X 0	Speed is correct	

- d. If the speed is too slow or too fast, adjust R130 on the PWR Driver PCB P/N (210-7594), shown in Figure 5-10 to obtain the "speed is correct" LED pattern.
- e. Conclude the test by setting the test switches to the following pattern:

Figure 5-10 Power Supply Test Points

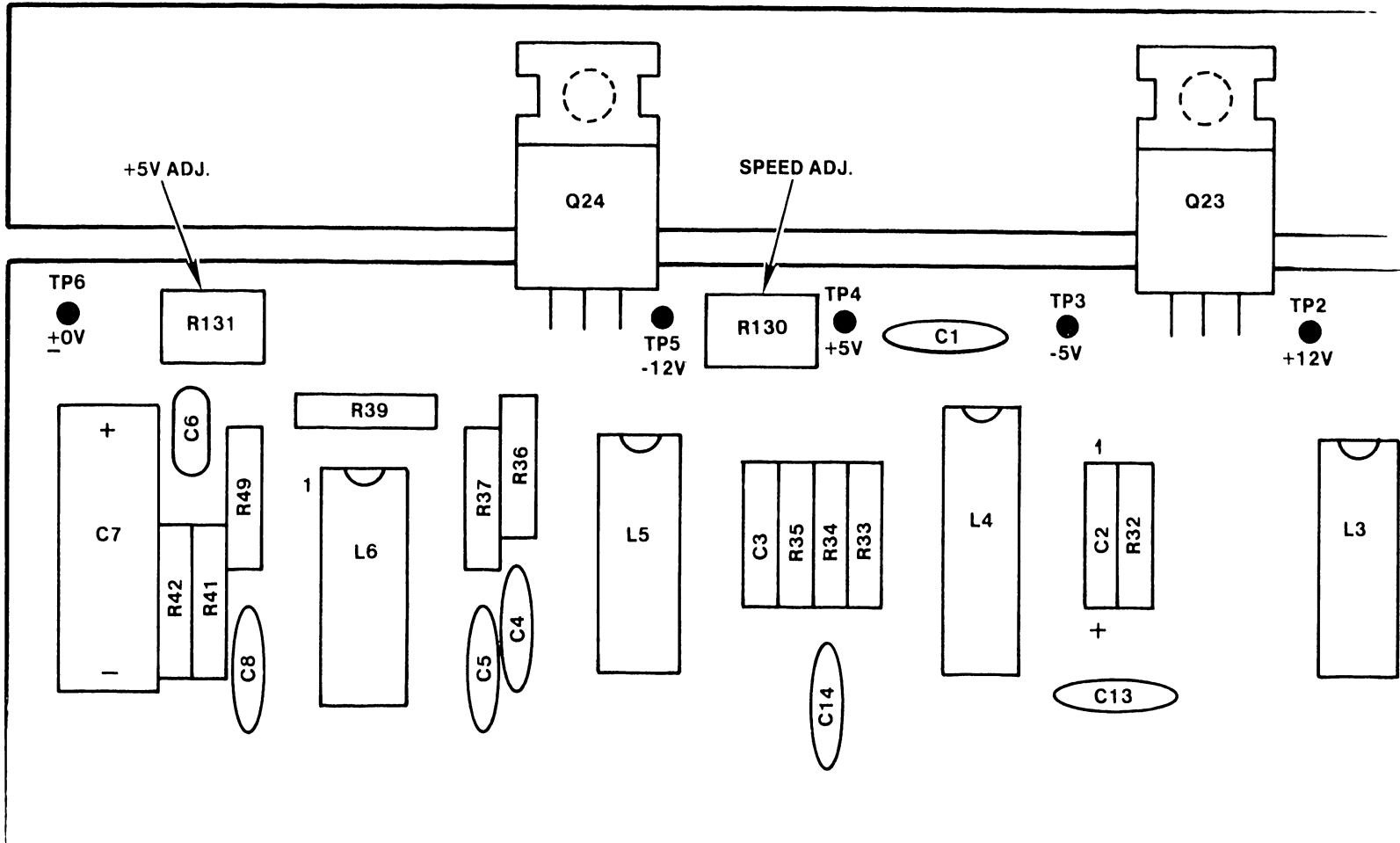

5.3.19 Right Sensor Check

- a. Press the SELECT switch until the SELECT indicator lights.
- b. Set test switches 2, 4 and STROBE to ON.
- c. Initiate the vertical bar print test by pressing and releasing the SELECT switch and turning OFF the SELECT indicator.
- d. While printing approximately 10 lines of vertical bars, observe that only the two middle test indicators illuminate as the carriage is sweeping across the paper.

NOTE: To stop the test, press and release the SELECT switch (SELECT lamp ON).

- e. Check each line of vertical bars to see that the rightmost bar is aligned with the rightmost bar in the line above and the line below.
- f. If an incorrect indication is noticed in either step d. or step e. perform the Right Sensor adjustment procedure in Paragraph 5.3.21.

5.3.20 Right Carriage Limit Sensor Adjustment

- a. Slightly loosen the two screws that fasten the right sensor to the bottom plate. See Figure 5-7, for carriage limit sensor location.
- b. Using the SELECT switch, initiate a two-line printout and stop the carriage at the left.
- c. Initiate another two-line printout and again stop the carriage at the left. Check that the right-most vertical bars of both lines match up as shown below. If not, reposition the right sensor and repeat this step until the lines match up.
- d. Tighten the right sensor mounting screws and recheck for correct indications as specified in step b.

5.3.21. Paper Tension Spring Check

- a. Print several pages of single thickness paper (not a multipart form). If the left or right tractor sprockets rip or distort the paper holes, perform the spring adjustment in Paragraph 5.3.22.
- b. Move the print head retraction lever to the fully retracted position. Measure the distance from the striker bar to the paper spring. See Figure 5-11. It should be no less than 1/16" (1.6mm) minimum. If not at least 1/16", perform the spring adjustment in Paragraph 5.3.22.

5.3.22 Paper Tension Spring Adjustment

- a. Insure the print head retraction lever is fully retracted. Loosen the two screws at the base of the paper tension spring illustrated in Figure 5-11.
- b. Adjust the paper spring to striker bar clearance should be a minimum gap of 1/16" (1.6mm).
- c. Pull paper up with even pressure on both sides. Widen paper spring to striker bar gap if the paper spring bends.
- d. Loosen two screws to slide spring in and out for proper gap and spring load against paper.

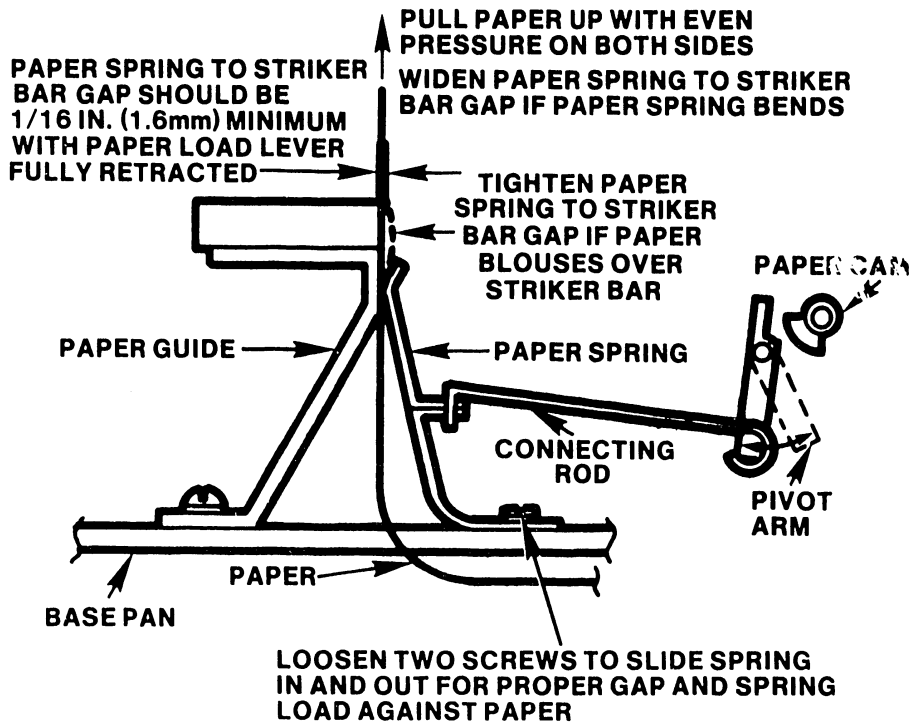

Figure 5-11 Paper Tension Spring Check

5.4 REMOVAL and REPLACEMENT PROCEDURES

5.4.1 Motherboard P/N 279-5233-70, P/N 279-5233-66 (Figure 5-12).

- a. Disconnect signal cable connector(s) on rear panel and pull power cable from the power source outlet.
- b. Remove the metal guide shield behind the paper tractors. The shield is mounted with four screws, two on each end. Remove screws and shield.
- c. Remove the PCB retainer bracket and remove all boards.
- d. Remove all cable connectors attached to the motherboard.
- e. Remove the eight screws that attach the motherboard to the baseplate. Unscrew and remove the shaft that supports the front end of the PCB retainer bracket.
- f. Remove the six screws that support the rear connector panel.
- g. Carefully lift the motherboard from the printer.
- h. To install, repeat the above steps in the reverse order.

CAUTION: Insure that all six screws are installed in the rear connector panel. These screws provide an electrical bond required for static elimination.

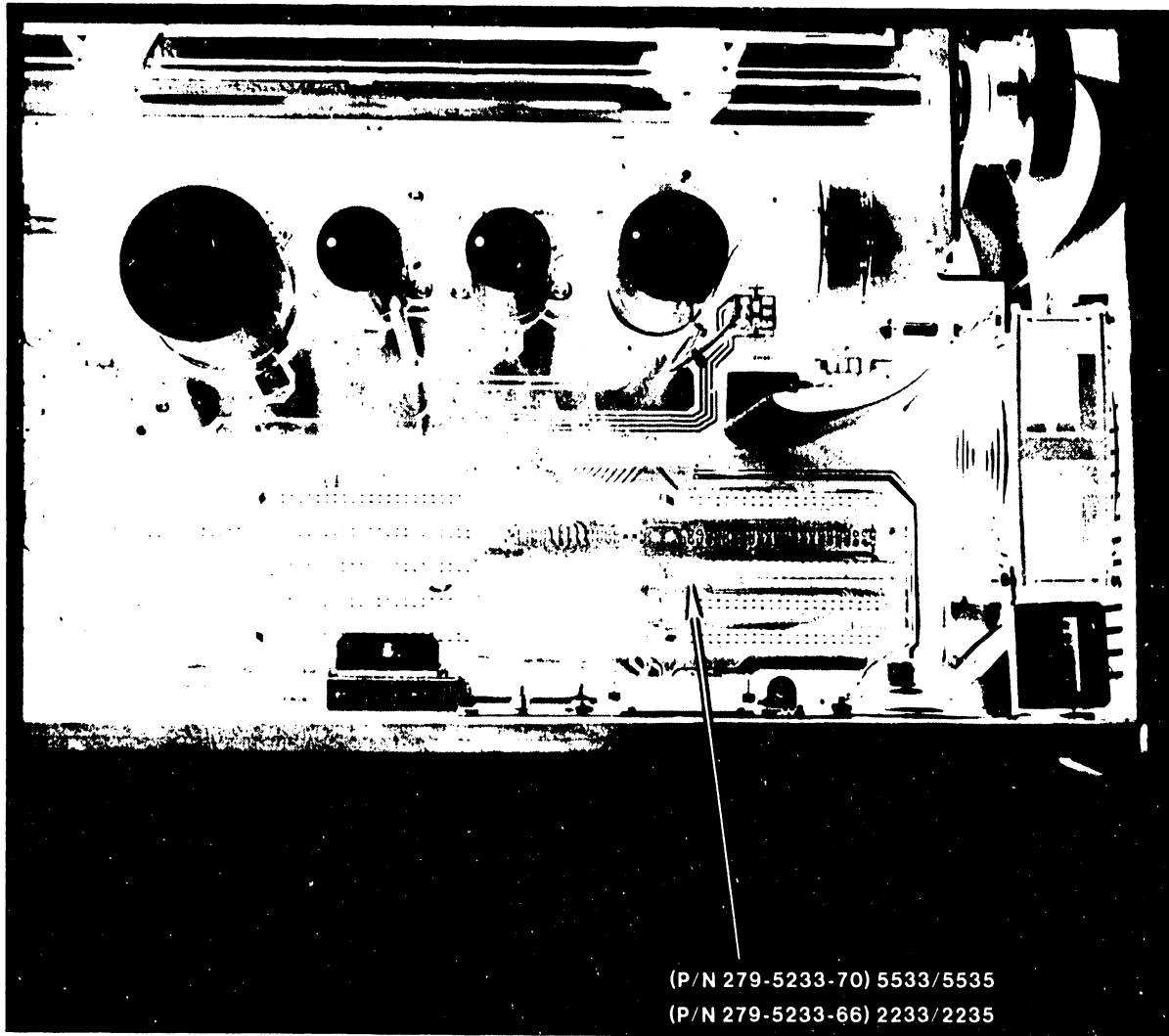

Figure 5-12 Motherboard Removal

5.4.2 Print Head Flex Cable P/N (220-3142).

Replace the print head flex cable as shown in Figure 5-13 per the following procedure.

- a. Remove the ribbon cartridge.
- b. Unplug the print head from the ribbon cable.
- c. Remove the two Phillips-Head screws on the head carriage that fasten the flex cable to the carriage. Remove the flat plastic clamp from the cable connector and remove the cable from the carriage assembly.
- d. Remove the other end of the flex cable from the connector on the Pwr Driver PCB P/N (210-7594).
- e. Loosen the two screws that attach the fan to the fan bracket. Shift the fan slightly to provide clearance for cable removal.
- f. Remove the flex cable from the flat cable clamps.
- g. To install a replacement cable, perform the above procedure in the reverse sequence. As a final step, retighten the fan screws loosened in step e.

5.4.3 Keyboard Cable P/N (220-3141).

Perform the following procedure to replace the keyboard cable

- a. Note the orientation of both ends of the keyboard cable connector to insure that the replacement cable is installed in the same way.
- b. Disconnect the cable from the keyboard printed circuit board, then disconnect the other end of the cable from the motherboard.
- c. To install a replacement cable, perform the above steps in the reverse sequence. Fold the replacement cable in the same manner that the removed cable was folded. If the printer does not operate following replacement of the cable, one of the cable connectors may have been reversed.

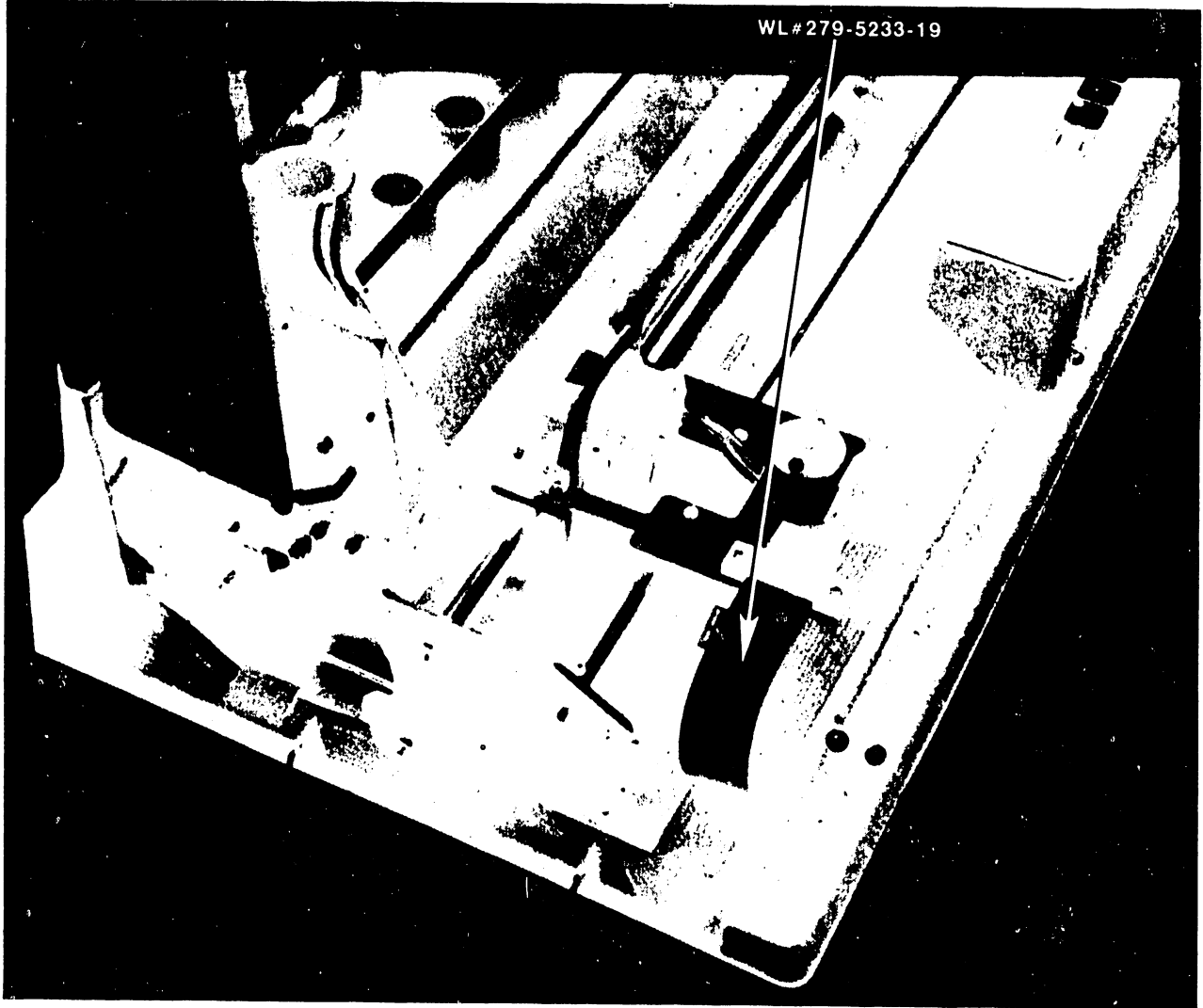

Figure 5-13 Print Head Flex Cable

5.4.4 Margin Sensor Cable Harness P/N (220-3184) See Figure 5-14.

- a. Remove the Phillips-Head screw that fastens the right margin sensor to the mounting bracket.
- b. Remove the Phillips-Head screw that fastens the left margin sensor to the mounting bracket.
- c. Pull plug J8 from the motherboard.
- d. Remove the cable harness with the attached right and left margin sensors.
- e. After installing the replacement cable, perform the encoder disk check and adjustment in Paragraphs 5.3.15 and 5.3.16.

5.4.5 Power Supply Assembly P/N (270-0690) See Figure 5-15.

- a. Remove the AC power cable from the rear panel.
- b. Remove top cover from the printer. See Paragraph 4.3 for cover removal procedure.
- c. Unplug the power supply cable from J1 on the motherboard.
- d. Remove four screws that fasten the power supply to the printer baseplate. Screw locations are as follows (from the rear of the printer): One screw is located at the front right of the transformer; the other two screws are located at the rear corners of the power transformer.
- e. Remove three screws from the power panel at the rear of the printer. Two of the screws are located next to the power line filter. The third screw is located above the other two screws.
- f. Pull the power connector from the fan and detach the fan cable from the hooks that support it.
- g. Remove the power supply.

CAUTION: Ensure to install all screws when re-installing the power supply. These screws provide an electrical bond required for static elimination.

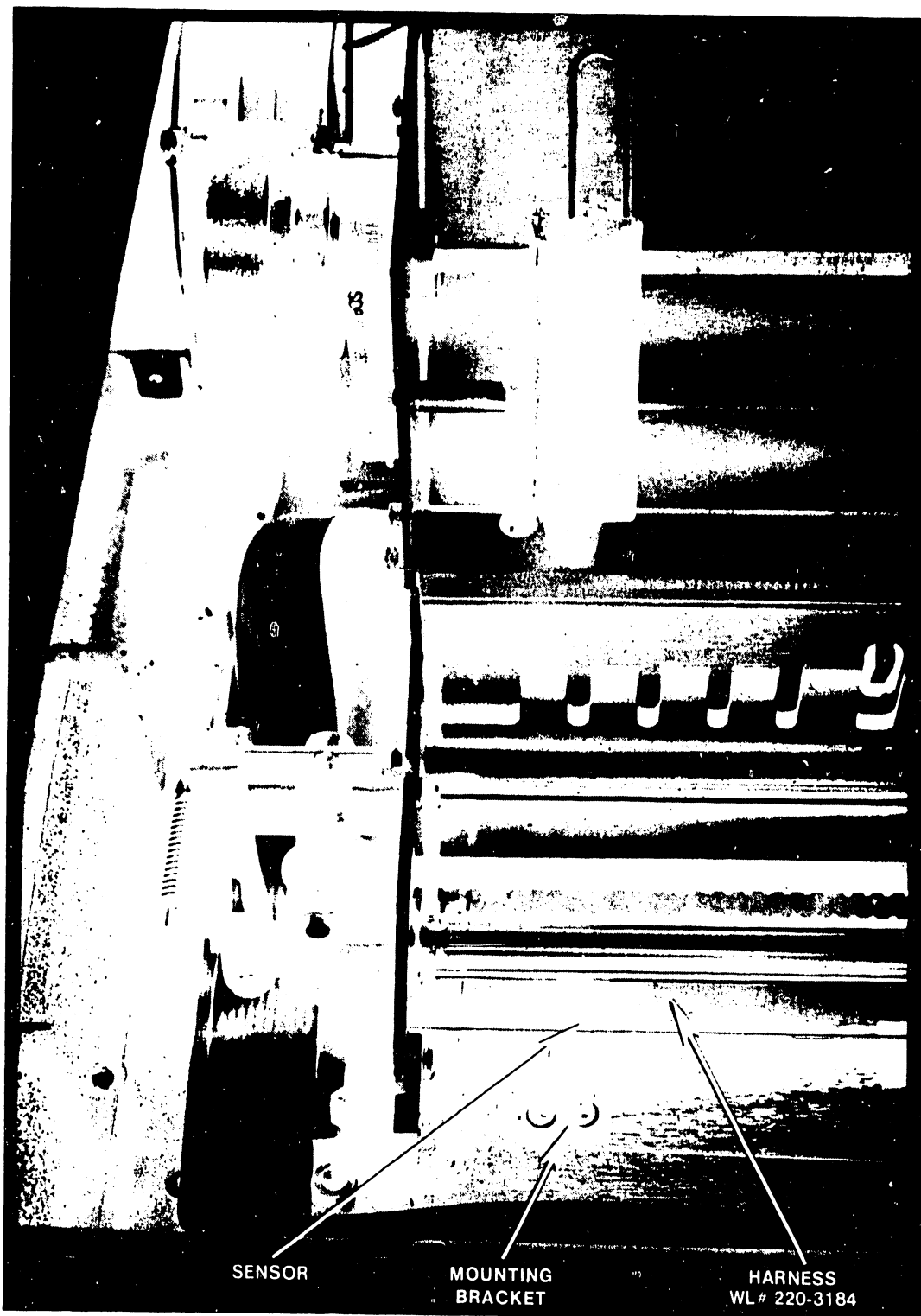
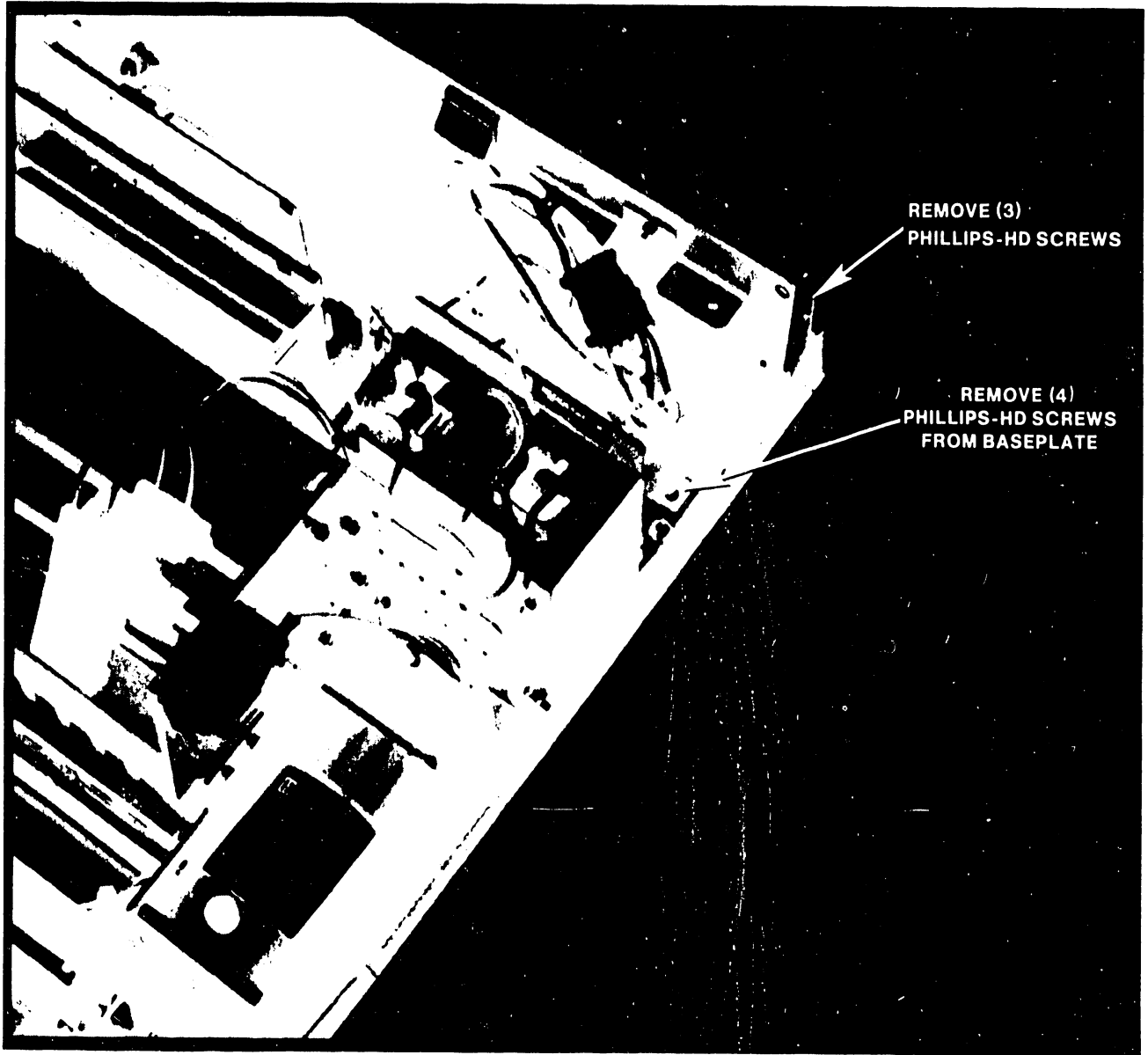

Figure 5-14 Margin Sensor Cable Harness



5-15 Power Supply Removal

5.4.6 Keyboard R & R P/N (271-1223, 271-1224) See Figures 5-16, 5-17.

- a. Remove the two Phillips-Head screws that fasten the cover over the LED indicators located to the right of the keyboard and remove the cover.
- b. Label the top of the cable connector to identify which side of the connector faces upward when it is reinstalled. Disconnect the cable.
- c. Remove the Phillips screw located on the left side of the DIP switch, then remove the keyboard.
- d. To reinstall, follow the above procedure in the reverse order. Note that the left end of the keyboard panel is fastened by means of a raised edge that hooks under the printer molding.

5.4.7 Print Head Carriage Drive Motor P/N (279-5233-15) See Figure 5-18.

- a. Unplug the encoder cable located at the rear of the carriage motor.
- b. Unscrew the two screws that attach the black encoder strobe wheel cover to the side plate.
- c. Disconnect the motor cable at J3 on the motherboard.
- d. Loosen the drive belt tension. See Paragraph 5.3.9 for location of the tension adjustment screw. Pull the drive belt from the motor pulley.
- e. Locate the three 1/4" hex head screws that fasten the carriage drive motor to the printer frame. Loosen, but do not remove the three screws.
- f. Slide the motor forward and lift it from the printer.
- g. To reinstall, follow the above steps in a reverse sequence. Perform the Drive Belt Tension Adjustment in Paragraph 5.3.9 and the Left Hand Margin Sensor Adjustment in Paragraph 5.3.12.

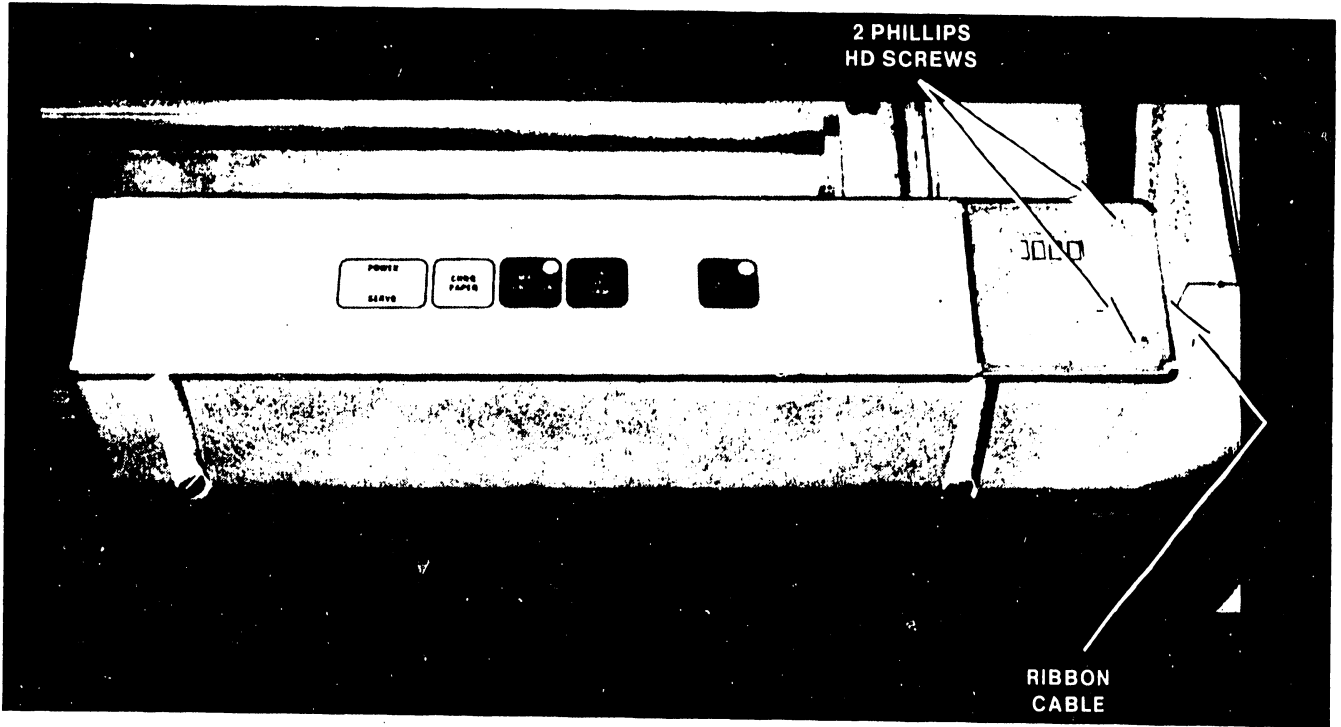

Figure 5-16 Keyboard Model 2233/2235 (P/N 271-1223)

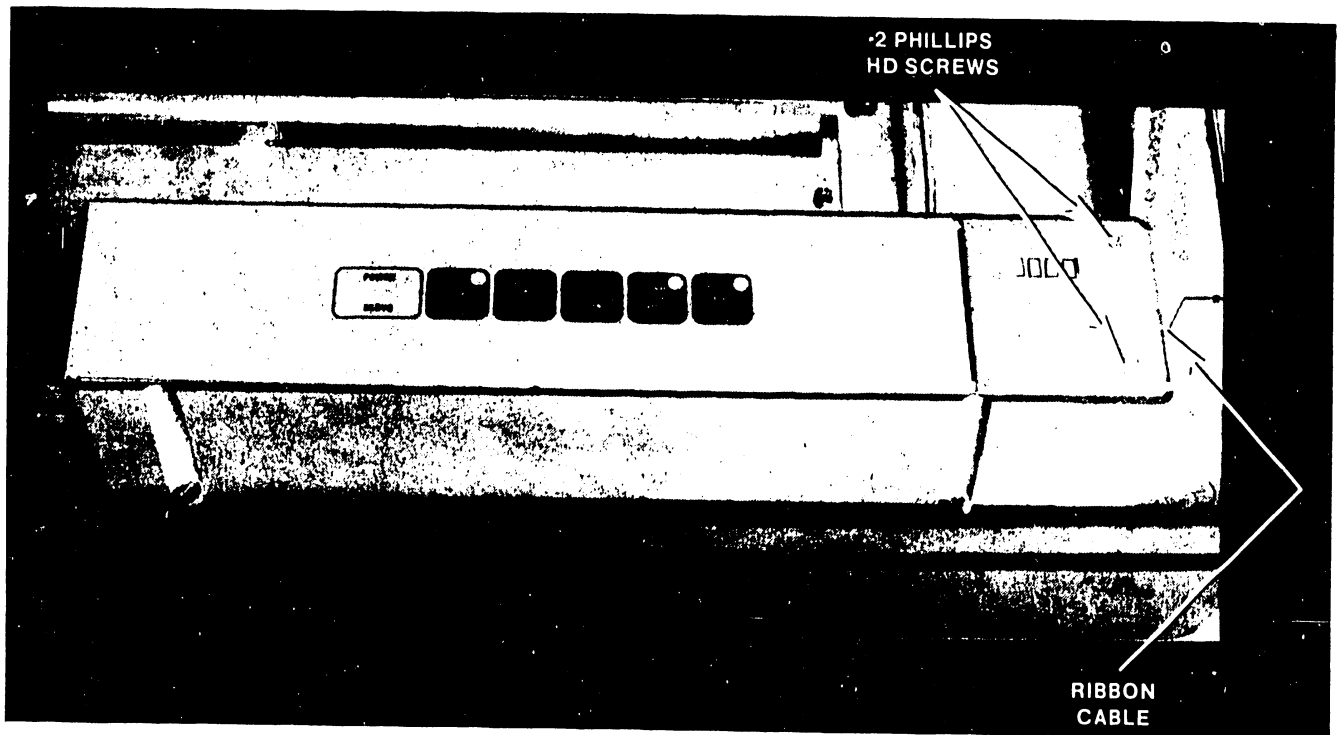

Figure 5-17 Keyboard Model 5533/5535 (P/N 271-1224)

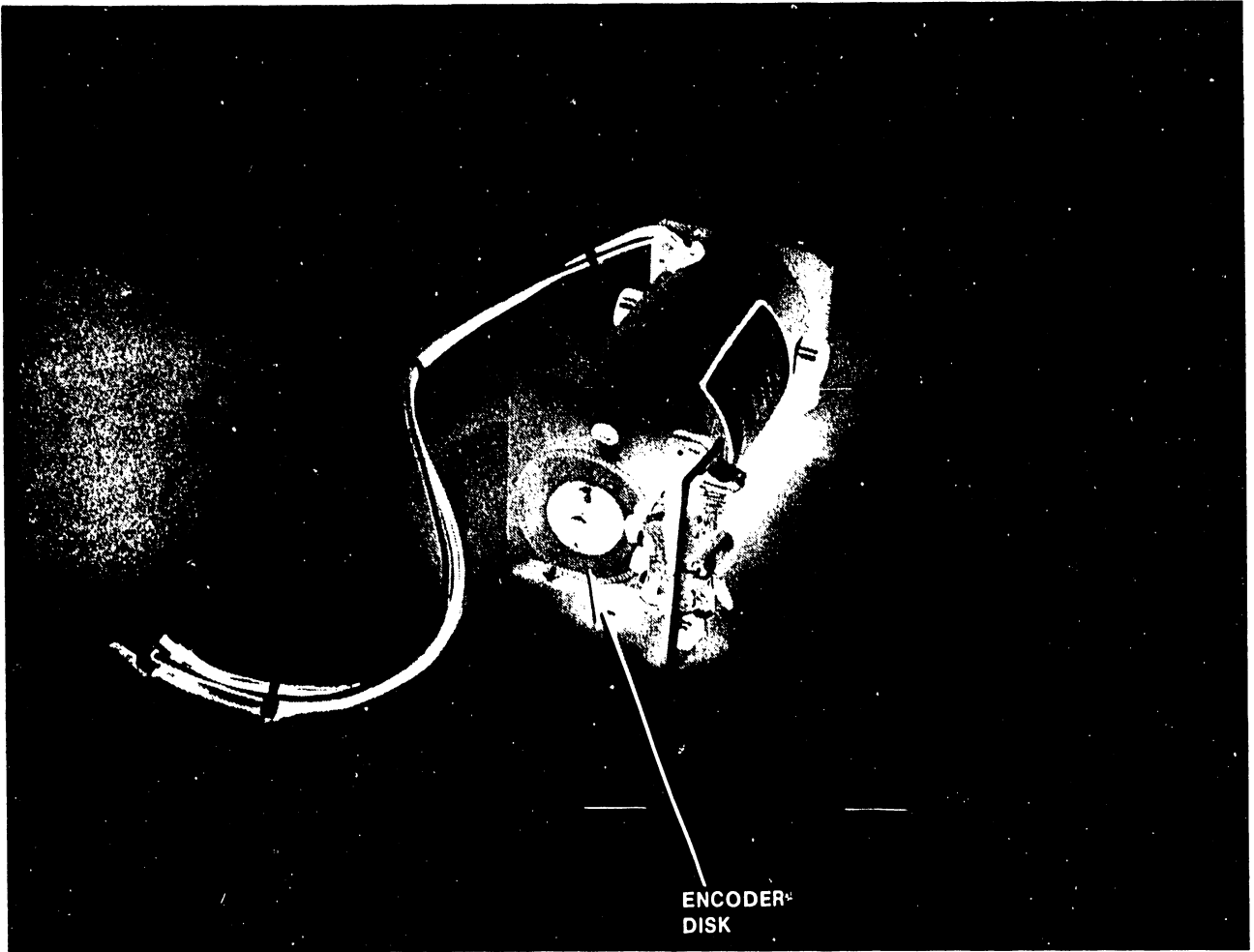

Figure 5-18 Print Head Carrige Drive Motor

5.4.8 Print Head Carriage Assembly Removal P/N (279-5233-19)
Figure 5-19.

- a. Remove the ribbon cartridge from the printer.
- b. Disconnect the flex cable at the print head.
- c. Remove the two Phillips screws that fasten the flex cable to the carriage assembly. Remove the flat cable clamp and remove the cable from the carriage assembly.
- d. Remove the print head and the print head bracket and place it in a box or other protective container.
- e. Remove the ribbon drive cable. To accomplish this, squeeze the cable tension spring to which the cable is attached. The spring is located internally at the right front of the printer. Unhook and remove the ribbon drive cable.
- f. Remove three self-tapping screws from the top of the carriage plate that fasten it to the front shaft bearing housing.
- g. To remove the plate, lift the front of the plate slightly and pull the plate toward the front of the printer.

5.4.9 Print Head Carriage Assembly Replacement (P/N 279-5233-19) See Figure 5-19.

CAUTION: When installing the carriage, be extremely careful to avoid damaging the spring loaded rear carriage roller.

- a. Locate the retaining clip attached to the bottom roller at the rear of the carriage plate. Using a pointed tool, push downward on the hole in the clip to which the spring is attached (this action will slightly lower the bottom roller to allow the carriage to slide readily onto the rear carriage rail). While pressing downward on the retaining clip, place the carriage assembly on the slide. Release the clip. The carriage is positioned on the front shaft bearing housing by two pins on the carriage plate.
- b. With the carriage in position over the shaft bearing housing, install the three Phillips head screws in the top of the carriage. Do not overtighten these screws because it is possible to strip the threads in the plastic material.
- c. Reconnect the ribbon drive cable using the threading diagram shown in Figure 5-20.
- d. Install the print head and mounting bracket.

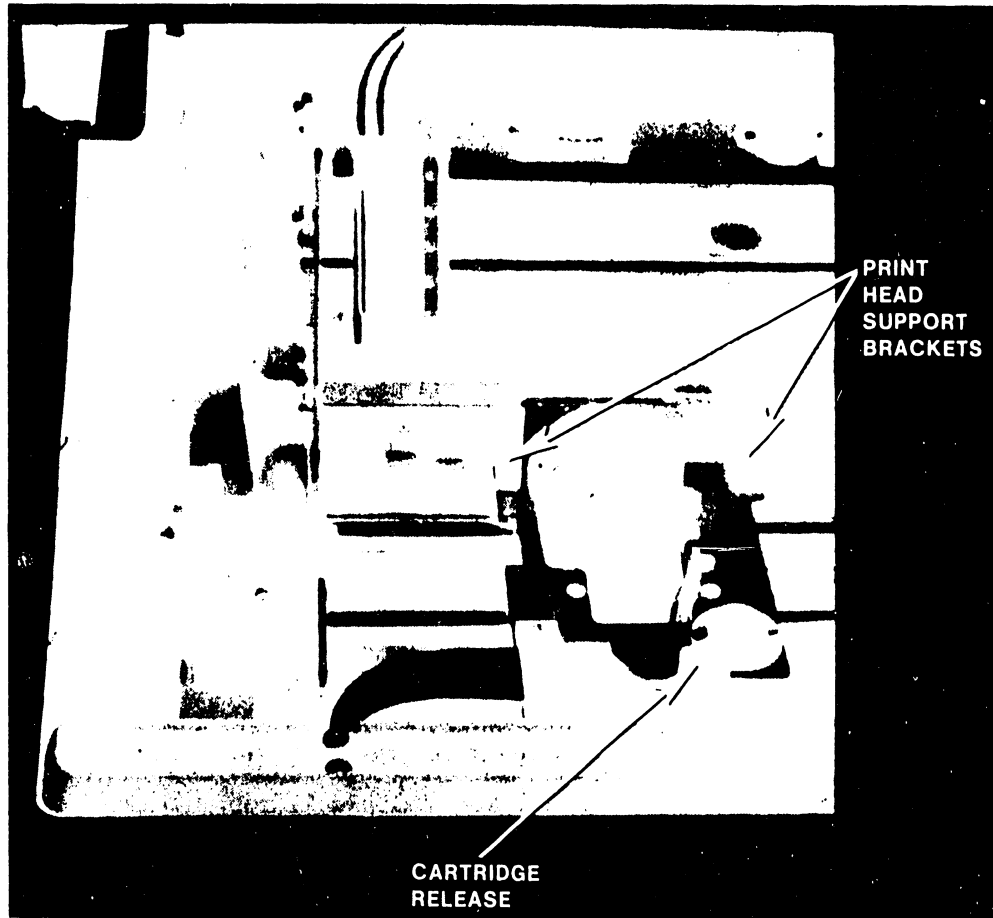

Figure 5-19 Print Head Carriage Assembly

- e. Mount the head flex cable connector on the carriage plate and attach the head cable to it.
- f. As a last step, perform the Print Head to Striker Bar Adjustment in Paragraph 5.3.4.

5.4.10 Paper Feed Motor P/N (279-5233-37)

- a. Remove the Driver/PS Regulator PCB P/N (210-7594).
- b. Remove the cable connected to J6 on the motherboard.
- c. Remove the three screws that attach the paper feed motor to the side plate of the printer.
- d. Position the motor to loosen the drive belt and remove the motor.
- e. To reinstall motor, follow the steps above in the reverse sequence.
- f. Perform the Paper Feed Belt Tension Adjustment in Paragraph 5.3.10.

5.5.11 End Cap P/N (449-0404)

Current production printers use an end cap that snaps into place on the end of the shaft. The cap cannot be removed from the shaft without breaking a plastic locking tab inside the cap. There is no need to remove this cap.

5.5.12 Vernier Cone P/N (449-0405) Vernier Pulley P/N (449-0406)

The vernier cone and the vernier pulley are replaceable by pulling the upper (rectangular) shaft from the printer using the following steps.

- a. Locate the cover open switch on the right side of the printer.
- b. Remove the grip ring from the right end of the top (rectangular) tractor feed bar.
- c. Release the locks on the two tractor assemblies.
- d. Carefully pull the rectangular bar from the left side plate of the printer. The vernier cone and vernier pulley can now be removed from the shaft and replaced.
- e. To reinstall, follow the above steps in the reverse sequence.

Figure 5-20 Top and Bottom Pulley Cable Diagram

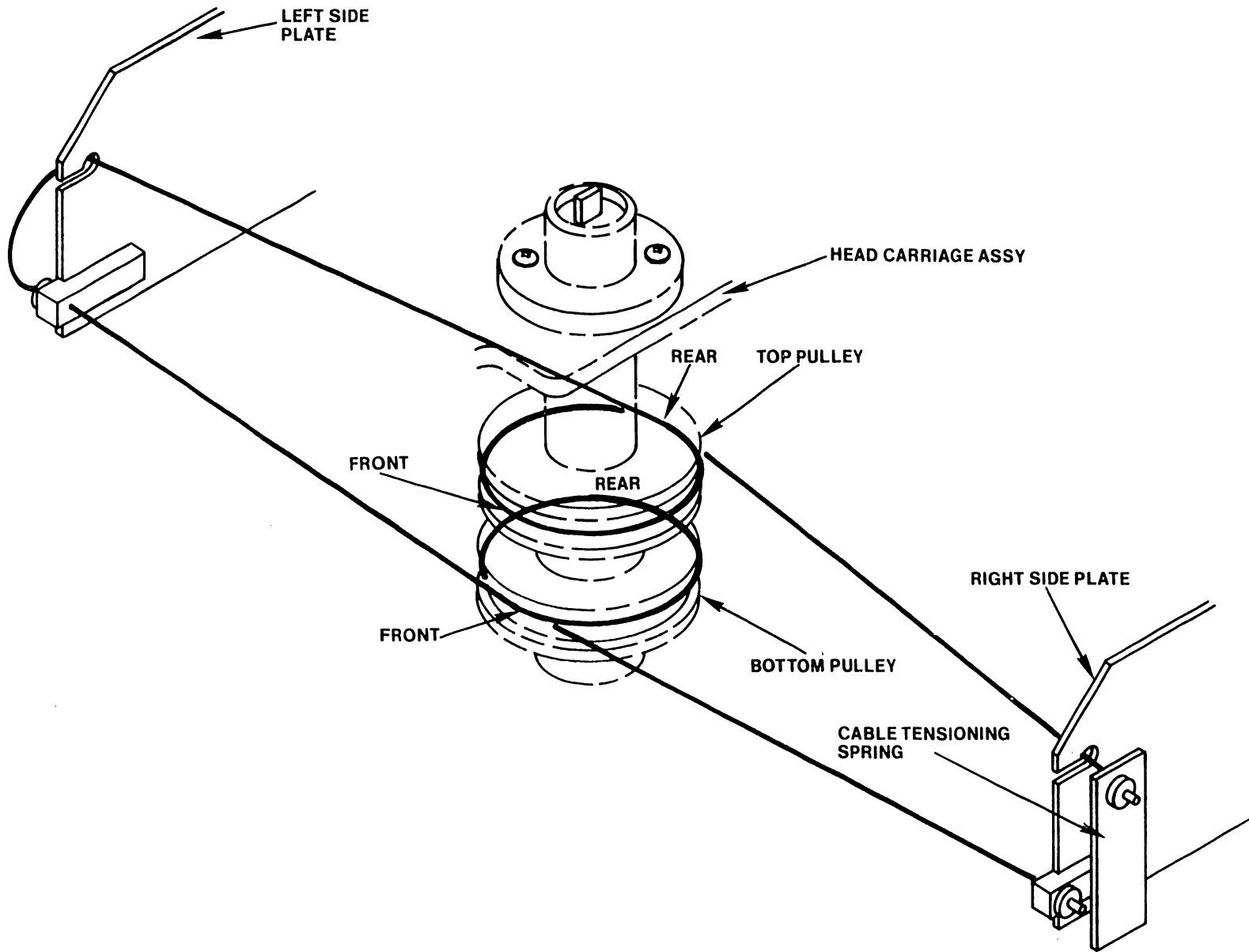

5.4.13 Wire Rope Assembly P/N (600-9106)

- a. Remove carriage drive cable. To accomplish this, squeeze the cable tension spring located at the right end of the cable and unhook and remove the cable. Reinstall the carriage drive cable using the threading diagram shown in Figure 5-20.

5.4.14 Print Head P/N (725-0096)

- a. Remove the print head and mounting bracket.
- b. Disconnect the flex cable from print head connector.
- c. Remove two 3/32" Allen cap screws that attach to the head the mounting bracket and remove head.
- d. To install the print head, perform the removal procedure in reverse.
- e. Perform the Print Head to Striker Bar Check and Adjustment per Paragraphs 5.3.3., 5.3.4.
- f. Check the position of the molded ribbon guide located at the front of the print head. The ribbon guide should have a clearance gap of $.017" + .001"$ with respect to the striker bar. If not, loosen the two Phillips screws that attach the guide to the print carriage. Adjust the position of the guide as required and retighten the two screws.

5.4.15 Paper-Feed Tractor Removal (P/N 725-1212, 725-1213) Figure 5-21.

- a. Locate the cover open switch on the right side of the printer.
- b. Remove the grip ring from the right end of the top (rectangular) and bottom (round) tractor feed bar shafts.
- c. Release the locks on the two tractor assemblies by pushing upward on the locking tabs.
- d. Carefully slide the top and bottom bar shafts to the left a few inches.
- e. Slide the paper tractors from the bar shafts.

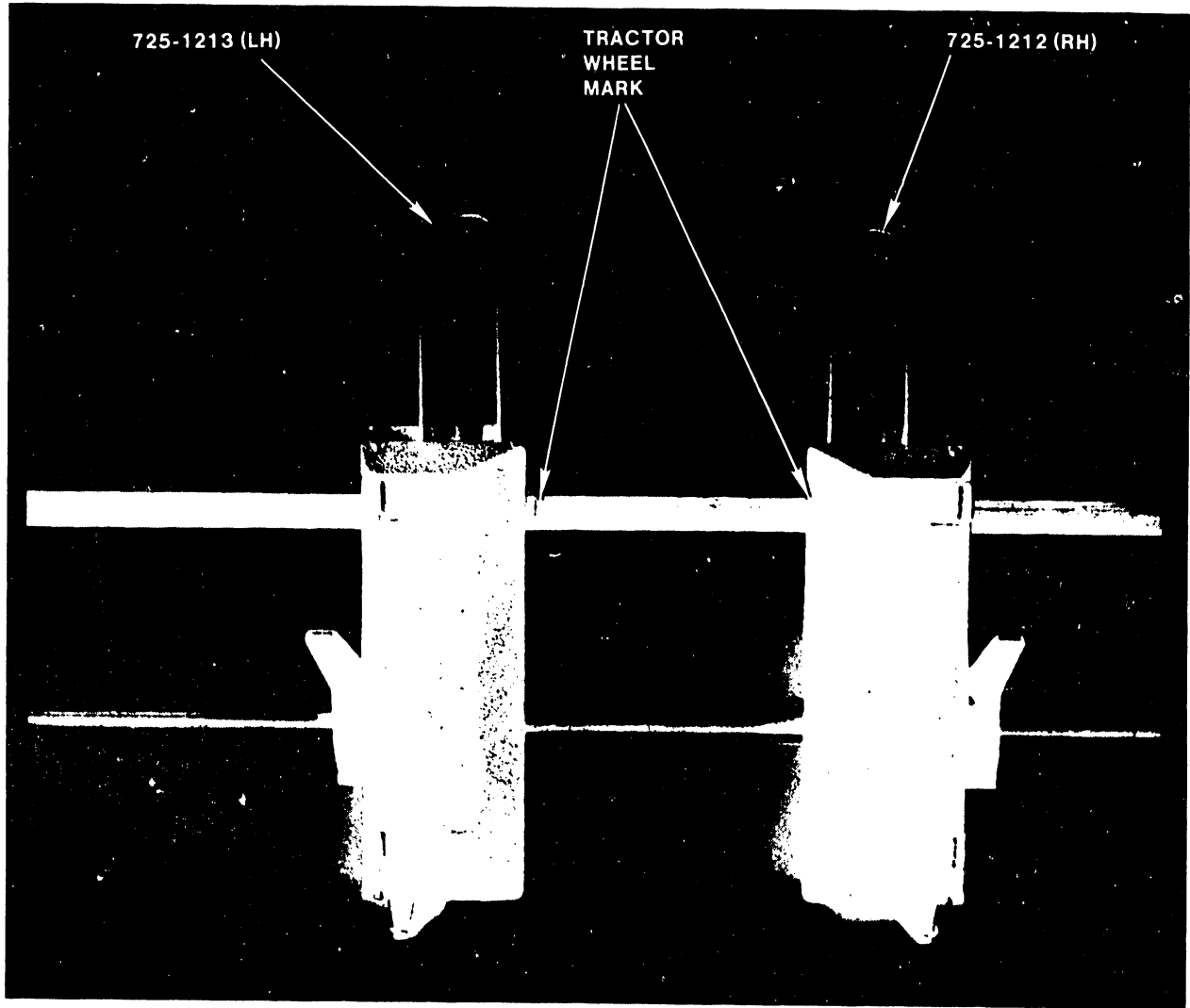

Figure 5-21 Paper Feed Tractor

5.4.16 Paper-Feed Tractor Replacement (P/N 725-1212, 725-1213)

- a. Slide the LEFT hand tractor onto the two bar shafts. Locate the mark on the right side of the top tractor wheel. Install the right hand tractor on the shaft so the marks on both tractor wheels are located on the same surface of the rectangular bar shaft.
- b. Install the grip rings on the two bar shafts by pushing the shafts to the right with sufficient force to allow the grip rings to be pushed into place at the ends of the shafts. The round shaft must have no perceptible end play.
- c. Reinstall the drive belt on the sprocket.
- d. Perform the Paper drive Belt Adjustment in Paragraph 5.3.10. Tighten the stepper motor mounting screws.
- e. Reinstall the cover open switch bracket assembly.

5.4.17 Front Carriage Shaft Lubrication

Add three drops of Anderol #465 Synthetic Oil, WLI #660-0263, along the front carriage shaft, shown in Figure 5-22. Move the carriage back and forth to distribute the oil along the shaft surfaces.

CAUTION: Do not add oil to the rear carriage shaft that the carriage rollers ride on.

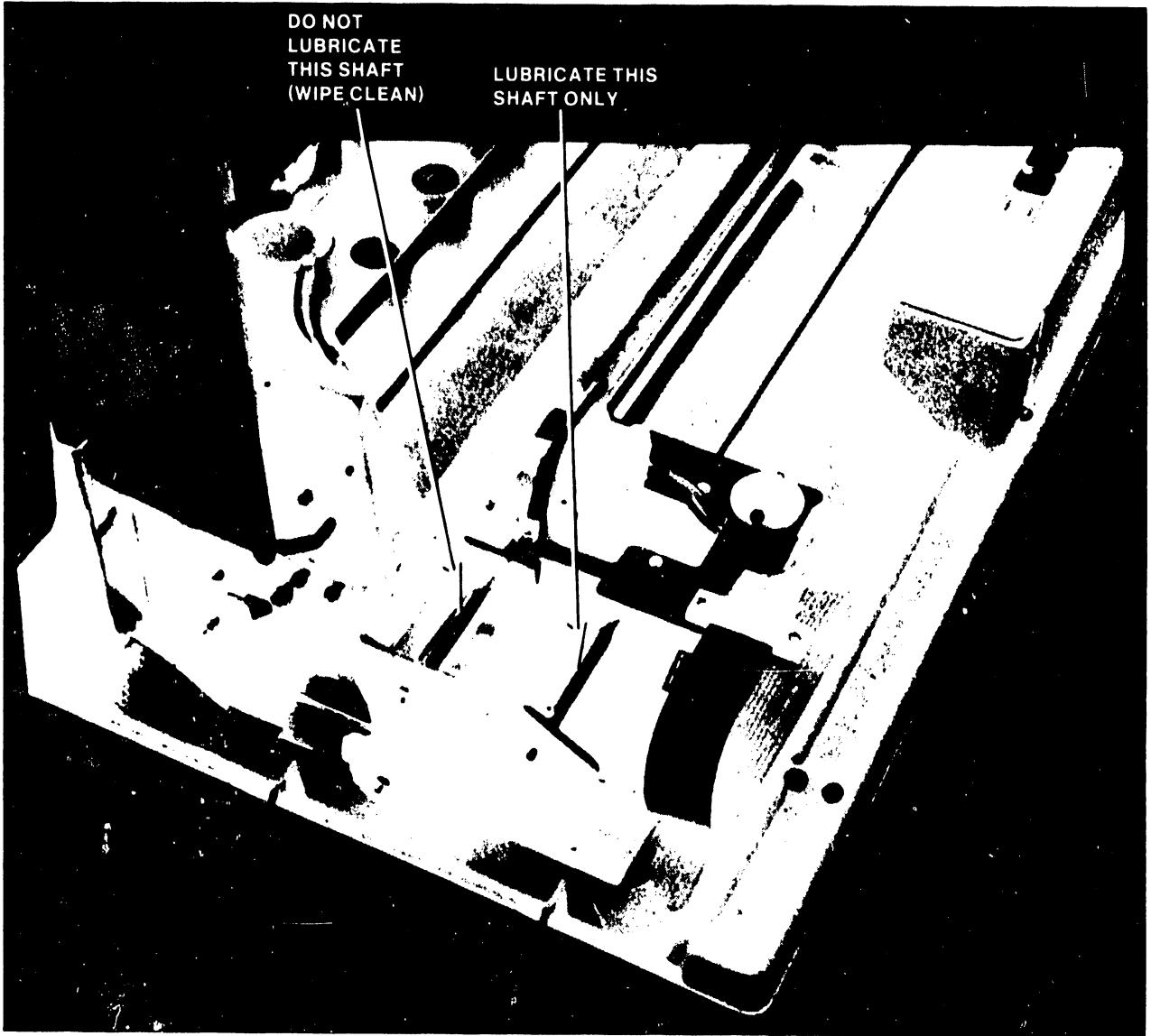

Figure 5-22 Carriage Shaft Lubrication

CHAPTER

6

SCHE-

MATICS

THE SCHEMATICS, WHEN AVAILABLE, ARE ON THE LAST FICHE IN THIS SET.

CHAPTER

7

ILLUSTRATED

PARTS

BREAKDOWN

CHAPTER 7
ILLUSTRATED PARTS
BREAKDOWN

7.1 INTRODUCTION

The following photo IPB provides reference to printer assemblies for maintenance procedures. Each parts list provides a key for those assemblies that are field stocked.

Page	Description
7-3	External Cover Assembly
7-6	Printer Mechanism (Frames Assembly)
7-10	Carriage Assembly 279-5233-1
7-12	Power Supply Assembly 270-0690
7-14	Motherboard Assembly 279-5233-69

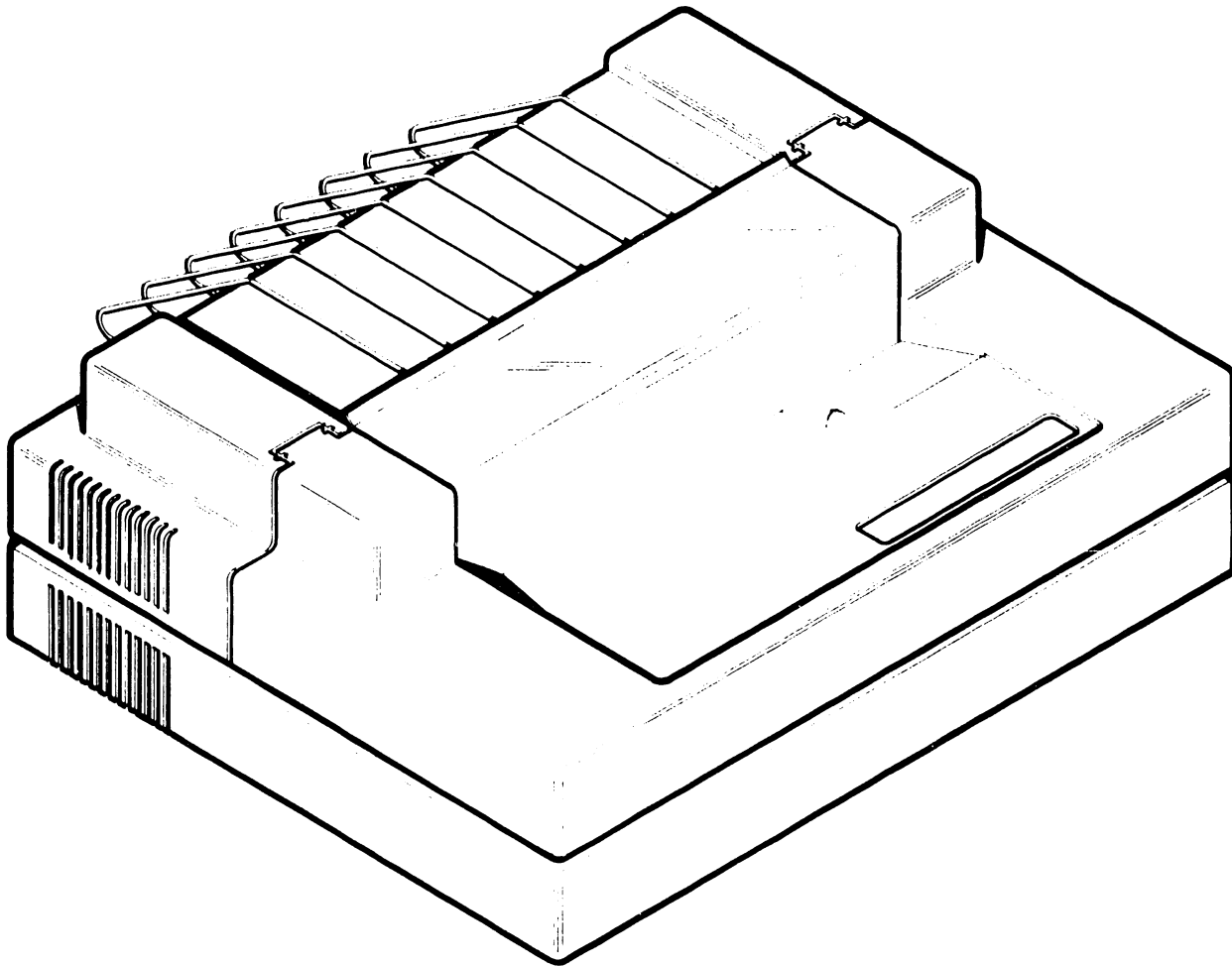

Figure 7-1 2233/2235/ 5533/5535 Matrix Printers

EXTERNAL COVER ASSEMBLY

Item #	Description	Part No.
1.	Paper Rack	458-1053
2.	Rear Cover	449-0258
3.	Front Cover	449-0260
4.	Torsion Bar, Front Cover	478-1043
5.*	Grommet 3/16 ID.	654-1204
6.*	Stud Ball (61)	461-3264
7.*	6-32 x 1/2 PH. PHL.Sems	650-3160
8.*	Latch, Cover Support	458-0974
9.	Shoulder Screw, Slotted	650-9064
10.*	Bracket, Staybar	451-5035
11.*	Lock Nut, ESNA	652-0063
12.*	Foam, Top L.S.	660-0925
13.*	Foam, Top Front	660-0922
14.*	Foam, Top Cover	660-0927
15.*	Foam, Bottom R.S.	660-0929
16.*	Foam, Bottom R.S.	660-0924
17.*	Foam, Bottom Right Corner	660-0920
18.*	Foam, Bottom Front	660-0931
19.*	SAME AS ITEM 34	
20.*	Foam, Bottom Left Corner	660-0921
21.	Foam, Bottom L.S.	660-0928
22.	Base, Cover Assembly	449-0281
23.*	Keyboard Assembly Parallel	271-1223
24.*	Keyboard Assembly - Serial	271-1224
25.*	6-32 x 1/4 PH.PHIL.	650-3085
26.*	Cable Clamp	654-1295
27.*	Guide, Paper Front	452-4110
28.*	Bracket, Carriage Sensor	449-0446
29.	1/4-20 x 1/2 Hex HD	650-9042
30.*	Nut, Base Tray	478-0338
31.*	Retaine, Nut	449-0169
32.	Pan, Base Assembly	279-5233-42
33.*	Grommet Standoff	654-1400
34.*	8-32 x 1/2 Sems	650-4160
35.*	No.8 Flat Washer	653-4000
36.*	8-32 x 3/8 PH.PHIL Sems	650-4120
37.	Plate, Nut Rear Panel	458-0888
38.*	Foam, Top L.S.	660-0925
39.*	Foam, Tope Cover	660-0927

*Indicates part is field stocked.

EXTERNAL COVER ASSEMBLY (cont'd)

40.*	8-32 x 3/4 PH.PHIL. Sems	650-4240
41.*	6-32 x 3/8 PH.PHIL. Sems	650-3120
42.	Ground Strap	220-1451
43.*	Bracket, Retainer	465-1749
44.	Retainer Hinge	458-0934
45.	Pin, Hinge Right Angle	478-1038
46.*	Spring, Coil	465-1748
47.*	4-40 x .50 Flat HD.PHIL.	650-2161
48.*	Latch	651-0304
49.	Standoff	462-0535
50.*	8-32 x 1/2 PH PHIL.	650-4120
51*	Sensor Assy.	270-3184
51a	Sensor, Assy	375-2120
52	Screw, FH. 2-56x1/4	650-0081
53	Bolt, Ship 1/4x20x2	650-9011
54	Cable, Keyboard	220-3141
55	Cable, Head	220-3142
56	Spring, Paper Feed	465-1745
57	Cover	452-2226
58	Screw, FH. 3-48x3/16	650-1061
59	Screw, 8-32x1/2 Whizlock	650-4084

*Indicates part is field stocked.

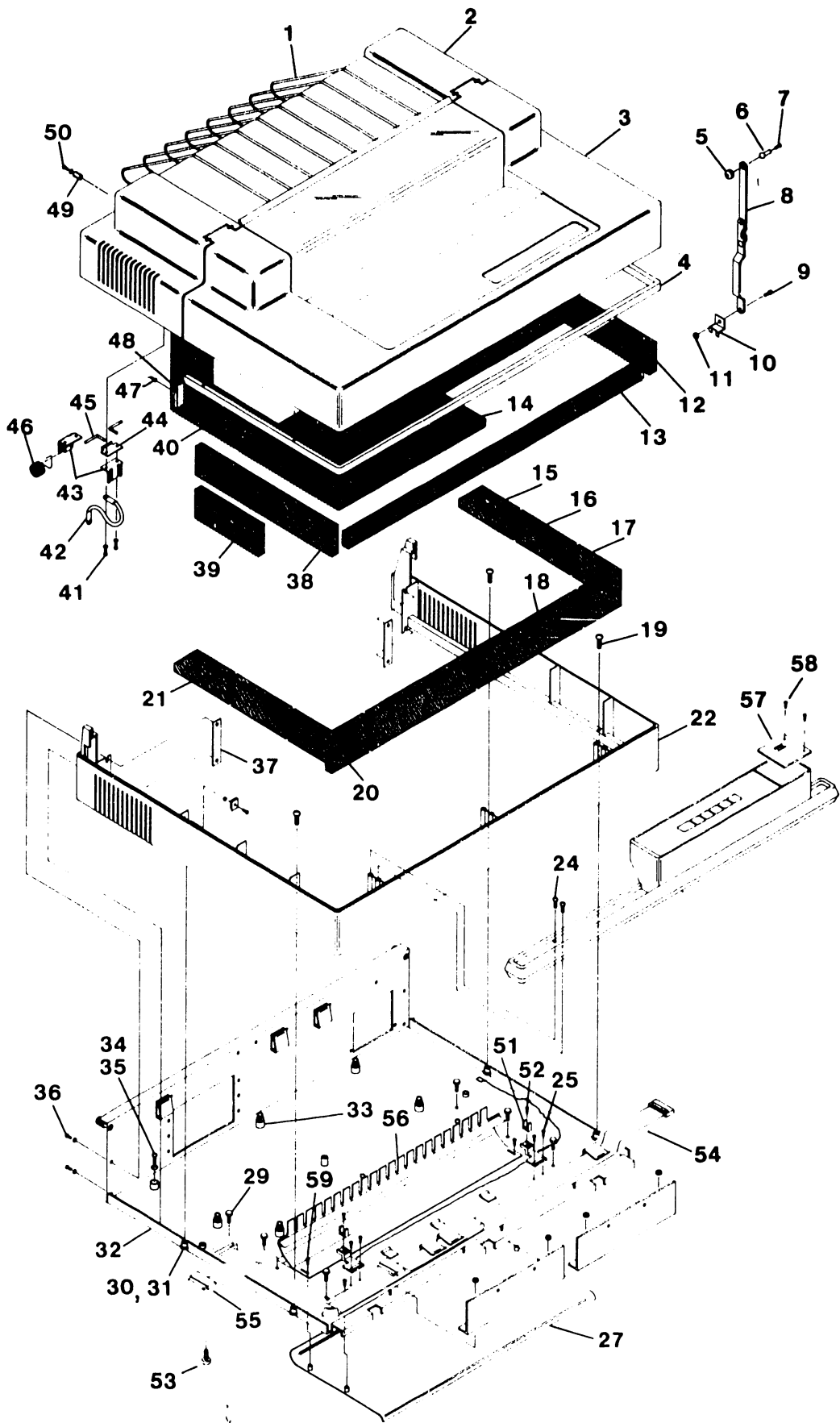

Figure 7-2 External Covers Assembly

PRINTER MECHANISM
(FRAMES ASSEMBLY)

Item #	Description	Part No.
1.	Retaining Ring	651-1749
2.	Feed Shaft	478-1034
3.*	Tractor, Paper Feed L.H.	725-1213
4.	8-32 x 1/2 Truss Screw	650-4169
5.	Guide Rod	478-1035
6.*	Tractor, Paper Feed R.H.	725-1212
7.	8-32 x 1/4 HP. Phl. Screw	650-4080
8.	Housing, Encoder	449-0391
9.	Part of 279-5233-15	0-80 x 5/16 Slot HP. Screw
10.	(Part MOTOR ASSY)	Encoder Hub Cap
11.	"	Encoder Disk
12.	"	Encoder Hub
13.	"	4-40 x 1/2 Soc. HD. Cap. Screw
14.	"	Encoder Hub Clamp
15.*	"	Encoder PCA
15a	"	Sensor
16.*	"	Motor, Carriage
17.	"	Pulley (Part of Motor Ass'y)
18.	"	No. 4 x 3/16 Self Tap Screw
19.	"	Encoder Sensor
20.*	"	Switch, Interlock
21.	"	Bracket, Interlock
22.	"	8-32 x 1/4 PH. Phl. Sems Screw
23.	"	No. 8 Plain Washer
24.	"	Baffle
25.	"	Retaining Ring
26.	"	8-32 x 5/8 Soc. HD. Longlok
27.*	"	Cam, Paper Spring
28.	"	Bearing, Unground LH. RH.
29.*	"	Bushing
30.	"	Pivot Arm RH.
31.	"	Tension Spring, Ribbon Drive
32.*	"	Wire Rope Assembly
33.	"	Cable Guide
34.	"	Rod, Paper Spring
35.	"	8-32 x 1/4 Whiz Lock Srew
36.	"	Carriage Bumpers
37.	"	Carriage Shaft, Short
38.	"	Set Screw
39.	"	Shaft, Carriage
40.*	"	Belt, Timing
41.	"	Shaft, Carriage
42.	"	Guide Striker Weldment

*Indicates part is field stocked.

(FRAMES ASSEMBLY, CON'T)

Item #	Description	Part No.
43.	Striker Bar	478-1041
44.	Grip Ring, 5/8	651-1754
45.	10-32 Soc. HD. Screw	650-6163
46.	No. 10 Split Washer	653-6003
47.	Carriage Shaft Ext.	461-3507
48.	Plate, LH - RH	452-0198
49.	Pivot Arm, LH	449-0388
50.	Part of 279-5233-44 Retaining Ring	651-1728
51.	(PART OF LEVER ASSY) Support, Idler Arm	449-0390
52.	" Shaft, Idler Pivot	461-3508
53.	8-32 x 1/2 Truss HD. Screw	650-4169
54.*	Lever Load Crtg./Paper	449-0394
55.*	" Housing, Idler Pulley	449-0397
56.	" Spring, .360 OD 1.0 Lg	465-1683
57.	" 1/4-20 x 1 3/8 Soc. Cap	650-9040
58.	Dowel Pin	651-1676
59.	Nylon Washer	653-6024
60.	Pulley, Idler	449-0123
61.	" Housing, Cam Detent	449-0393
62.	Compression Spring	465-1739
63.	Cam, Matrix HD.	449-0395
64.	Cam Shaft	461-3509
65.	Shim Washer	653-0133
66.	Retaining Ring	651-1716
67.	Spring, Lever Load	465-1743
68.*	Dress Cap	449-0404
69.	Spring, Vernier Knob	465-1734
70.*	Cone, Vernier	449-0405
71.*	Bushing, 1.06 Lg	449-0403
72.*	Pulley Verneir	449-0406
73.	Timing Belt	656-0252
74.	Pulley, Feed Drive	449-0448
75.	Set Screw	650-3040
76.	No. 5 Flatwasher	653-3000
77.	6-32 x 2 PH. Phl. Screw	650-3640
78.	Counter Assembly, 6 Digit	279-5233-71
79.	Bracket, Counter	451-7084
80.	4-40 x 3/16 PH. Phl. Screw	650-2060
81.	6-32 Lock Nut Keps	652-0032
82.*	Fan Assembly	400-1003
83.	8-32 x 3/8 PH. Phl. Sems Screw	650-4120
84.	Bracket, Fan	451-7080
85.*	Motor Assembly, Paper Feed	279-5233-37

*Indicates part is field stocked.

(FRAMES ASSEMBLY, CON'T)

Item #	Description	Part No.
86.	Plate, Nut	461-0103
87.*	Switch, Paper Out	325-2403
88.	No. 4 Flat Washer	653-2000
89.	4-40 x 5/8 PH. Phl Screw	650-2200
90	Fan cord	400-9015
91*	Ball, 3/16	465-0298
92	Cable, Guide	449-0560
93*	Screw, 8-32 x 3/8 Phl.	650-4120
94	Screw, 6-32 x 1/4 Pan Hd.	650-3080
95	Washer, Clamp Striker Bar	452-2685
96*	Screw, 8-32 x 3/8 Ph. Phl	650-4120
97*	Washer, # 8 Flat	653-4000
98	Shim, Striker Bar	650-3167
99	Pan, Upper Paper	451-1271
100	Screw, 8-32 x 3/8 Ph. Phl	650-4120
101	Washer, # 8 Flat	653-4000
102*	Pin, Roll 3/32 x 5/8	650-4084
103	Cap	655-0070
104	Bumper	449-0496

*Indicates part is field stocked.

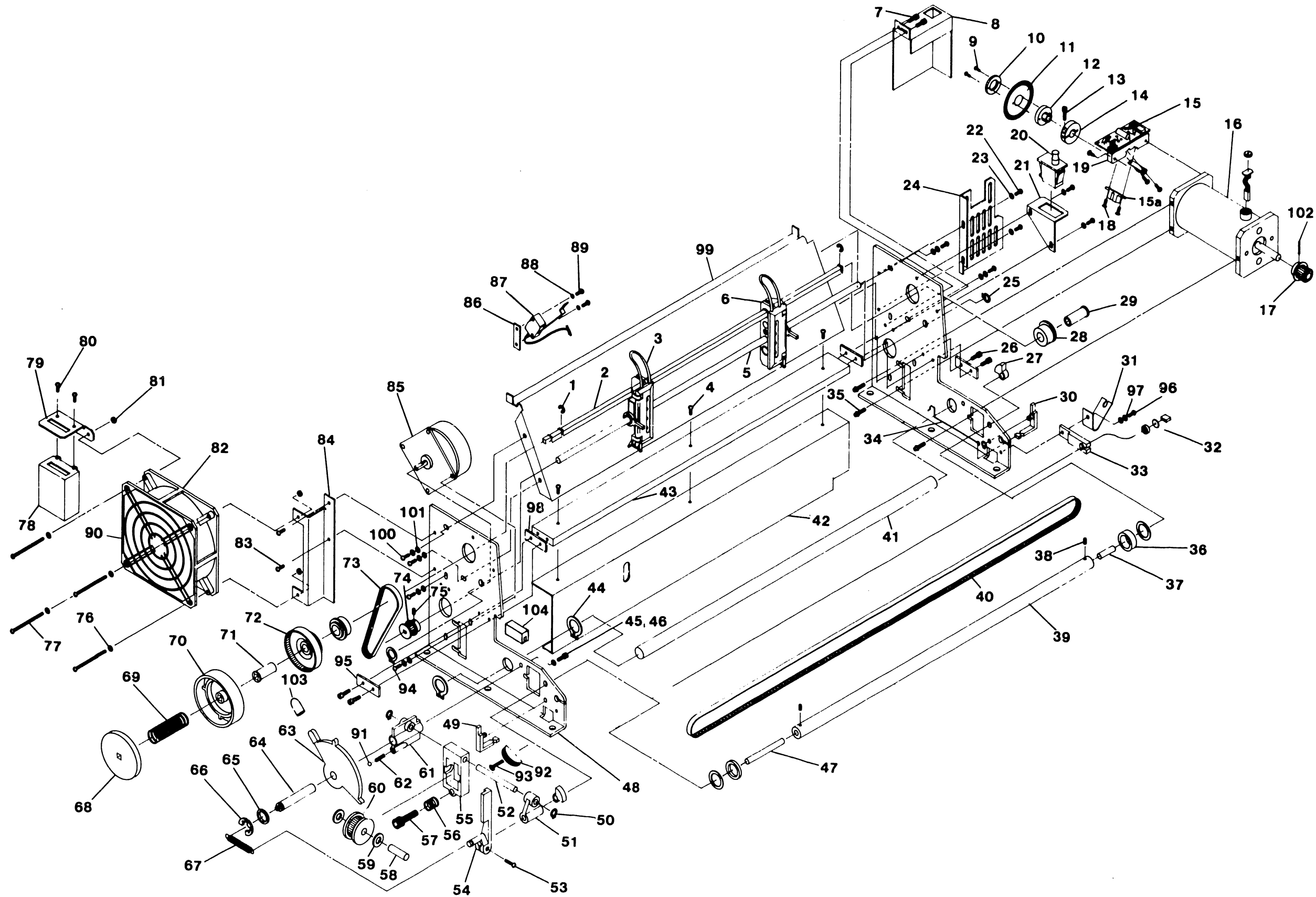

Figure 7-3 Frames Assembly

CARRIAGE ASSEMBLY
279-5233-79

Item #	Description	Part No.
1.*	Ribbon Guide	449-0504
2.*	Screw, 6-32 X 3/8 PH2	650-3120
3.	#6 Flat Washer	653-3000
4.*	Screw, 4-40 X 3/8 Socket Cap	650-2125
5.*	Screw, Ph1 6-32 X 3/8 PH	650-3120
6.*	Washer, #6 Flat	653-3000
7.*	Bracket	450-0911
8.*	Matrix Head	725-0096
9.	Screw, Socket 6-32 X 5/16	650-3104
10.*	Cartridge Guide	449-0134
11.	Cartridge Assembly Carriage	279-5233-21
12.	Screw, Tap #6 X 1/2	651-0019
13.*	Spring, Cartridge	465-1626
14.*	Retainer Ring	651-1719
15.	Shaft, Ribbon Drive	461-3529
16.*	Screw, PH, P#6 6-32 X 3/8	650-3120
17.*	Spring	465-1750
18.	Housing, Ribbon Drive	449-0387
19.	Pully, Wire Rope	449-0736
20.*	Retainer Ring	651-1719
21.	Screw, 6-32 X 1/4	650-3089
29.	Screw, Self Tap	650-3104
30.*	Clamp	449-0396
31.	Screw, 6-32 X 1/2 Ph1	651-3161
32.	Tail Bearing	465-0313

Not Included in Carriage Assembly

22.	Cover, Retainer	449-0138
23.	Washer, Felt	660-0910
24.*	Housing, Bushing	449-0383
25.	Carriage Flag Plate	458-0859
26.	Screw, Self Tap #6X3/8 PH	651-0061
27.	Clamp, Belt	449-0385
28.	Screw, 6-32 X 1/2 Ph1	651-0061

*Indicates part is stocked.

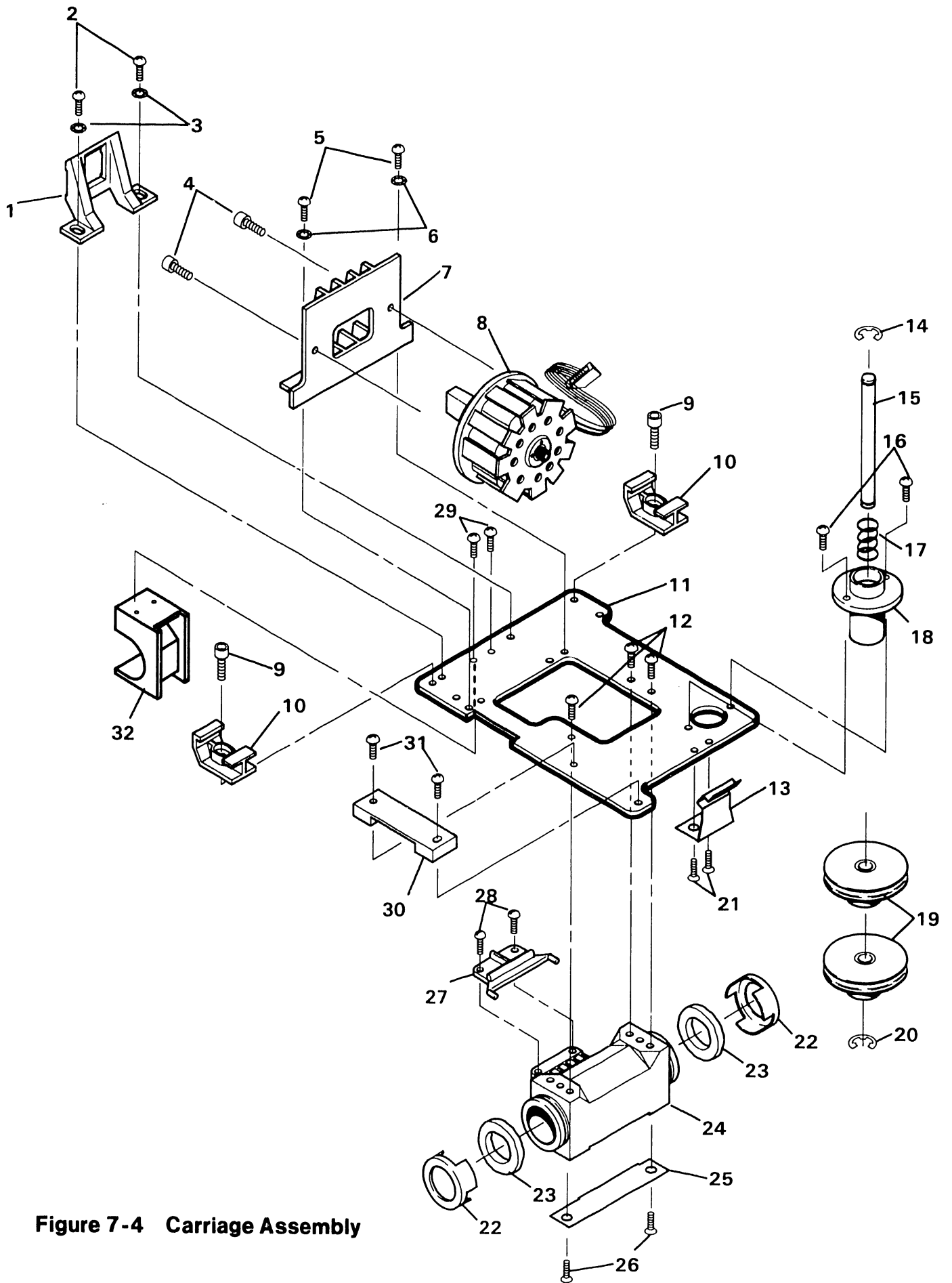

Figure 7-4 Carriage Assembly

POWER SUPPLY ASSEMBLY
270-0690

Item #	Description	Part No.
1.*	Rectifier, Halfwave	380-4005
2.*	No. 6 Flat Washer	653-3000
3.*	6-32 Nut Keps	652-0032
4.	Bracket, Transformer	451-5015
5.*	Rectifier, Bridge	380-4006
6.*	Power Conversion Cable	220-1501
7.*	6-32 x 3/4 Screw	650-3240
8.*	Part of 270-3183 Socket, 4 Position	654-1195
9.*	(TRANSFORMER ASSY Fan cord	420-1005
10.*	" Socket, 10 Position	654-1187
11.*	" Faston, Terminal	654-0134-R
12.	Faston, Lug	654-0188-R
13.*	No. 8-32 Lock Nut Keps	652-0029
14.*	No. 8 Flat Washer	653-4000
15.	Bracket, Transformer	452-2209
16.*	Line Filter	279-5233-72
17.	No. 6 Ring Lug	654-0050-R
18.*	Hex Nut	360-9002
19.*	Lock Washer	360-9003
20.*	Rubber Washer	360-9000
21.*	6-32 x 3/8 Ph. Phl Screw	650-3120
22.*	Power Switch	325-0055
23.	Fuse Holder	360-0013
24.	1.5 AMP Slow Fuse	360-1016SB
25.	3.0 AMP Slow Fuse	360-1031SB
25a	Fuse, 1.5 Amp 240V	360-1016SB
26.	Transformer	410-0172
27	Cord A C	420-1025

*Indicates part is field stocked.

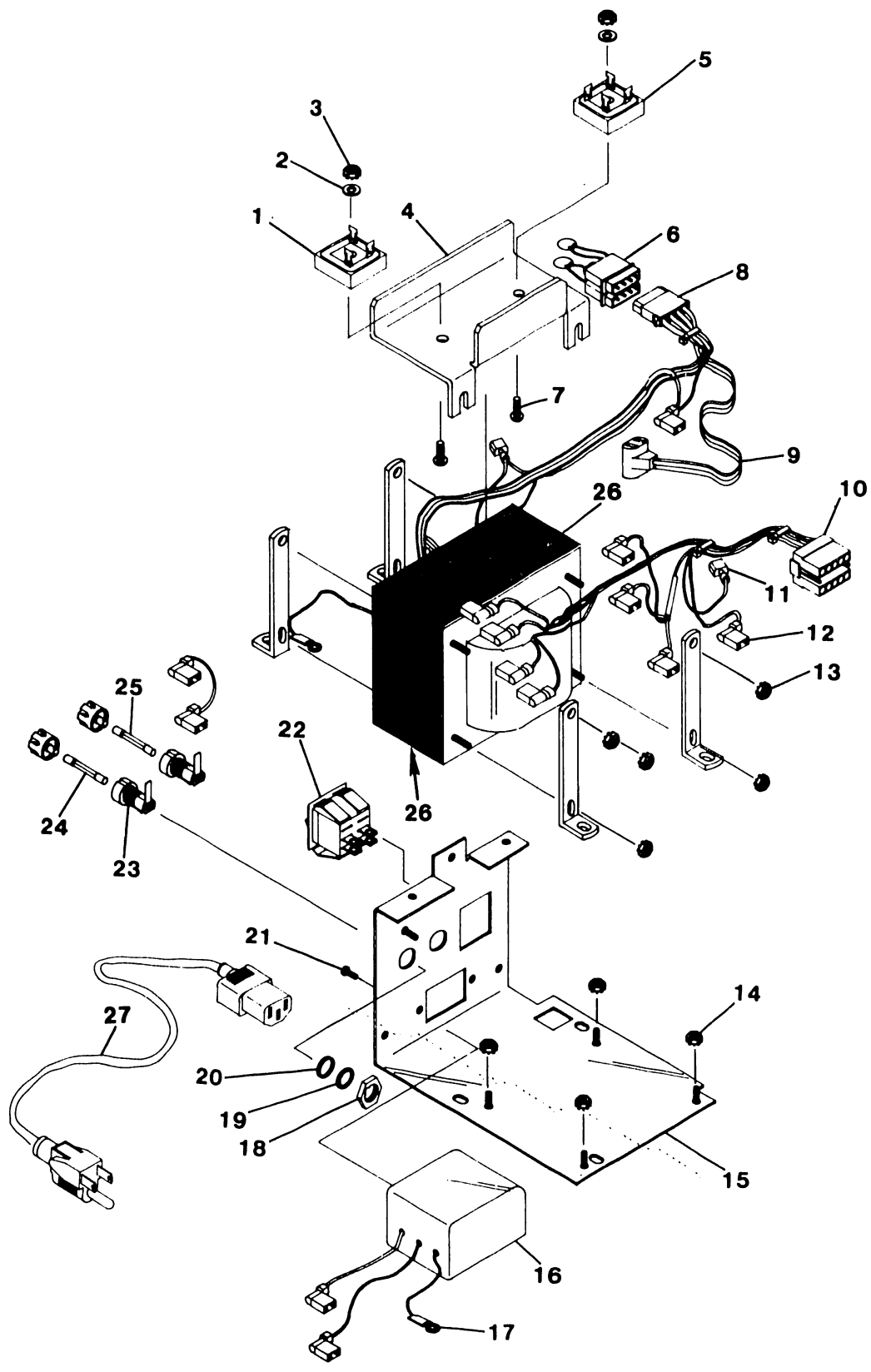

Figure 7-5 Power Supply Assembly

MOTHERBOARD ASSEMBLY
279-5233-69

Item #	Description	Part No.
1.	Bracket, PC Card	449-0434
2.*	8-32 X 3/8 PH Phl Sems	650-4120
3.*	No. 8 Flat Washer	653-4000
4.	Stand Off, PCB	462-0488
5.*	Driver/PS Reg. Assembly**	210-7594
6.*Part of 279- 5233-19	Cap, Electro. 53K mfd 25vdc**	300-3070
7.*	Clamp, Capacitor 2 1/2"***	300-9006
8.	Cap, Electro. 12K mfd 25vdc**	300-3076
9.*	Clamp, Capacitor 1 1/4"***	300-9009
10.*	Cap, Electro. 20K mfd 60vdc**	300-3316
11.*	6-32 Lock Nut Keps**	652-0032
12.*	6-32 X 5/8 PH Phl**	650-3200
13.*	8-32 X 3/8 PH Phl**	650-4120
14.*	8-32 Lock Nut Keps**	652-0029
15.*	Motherboard Parallel**	210-7595
	Motherboard Serial**	210-7595-1
16.*	6-32 X 3/8 PH Phl**	650-3120
17.*	No. 6 Flat Washer	653-3000
18.*	8-32 Lock Nut Keps	652-0029
19.*	Speaker, 8 Ohm	320-0300
20.*	6-32 X 1/4 PH Phl	650-3080
21.*	No. 6 Flat Washer	653-3001
22.	Conn, BNC Female	350-3064
23.	Conn, TNC Female	350-3065
24.*	PCB - CPU Daisy Printer	210-7348-A
25.*	PCB - 32K RAM Memory	210-7547-1A
26.*	PCB - CPU & IO	210-7593-1B
27.	Bracket, Connector	452-2231
28.	Bracket, Card Support	451-7073
29.	Diodes	380-3002
30.	Diodes	380-4000

* = Indicates item is field stocked

** = Parts for Parallel Motherboard Assembly. Use Part No. 279-5233-66

** = Parts for Parallel Motherboard Assembly. Use Part No. 279-5233-66

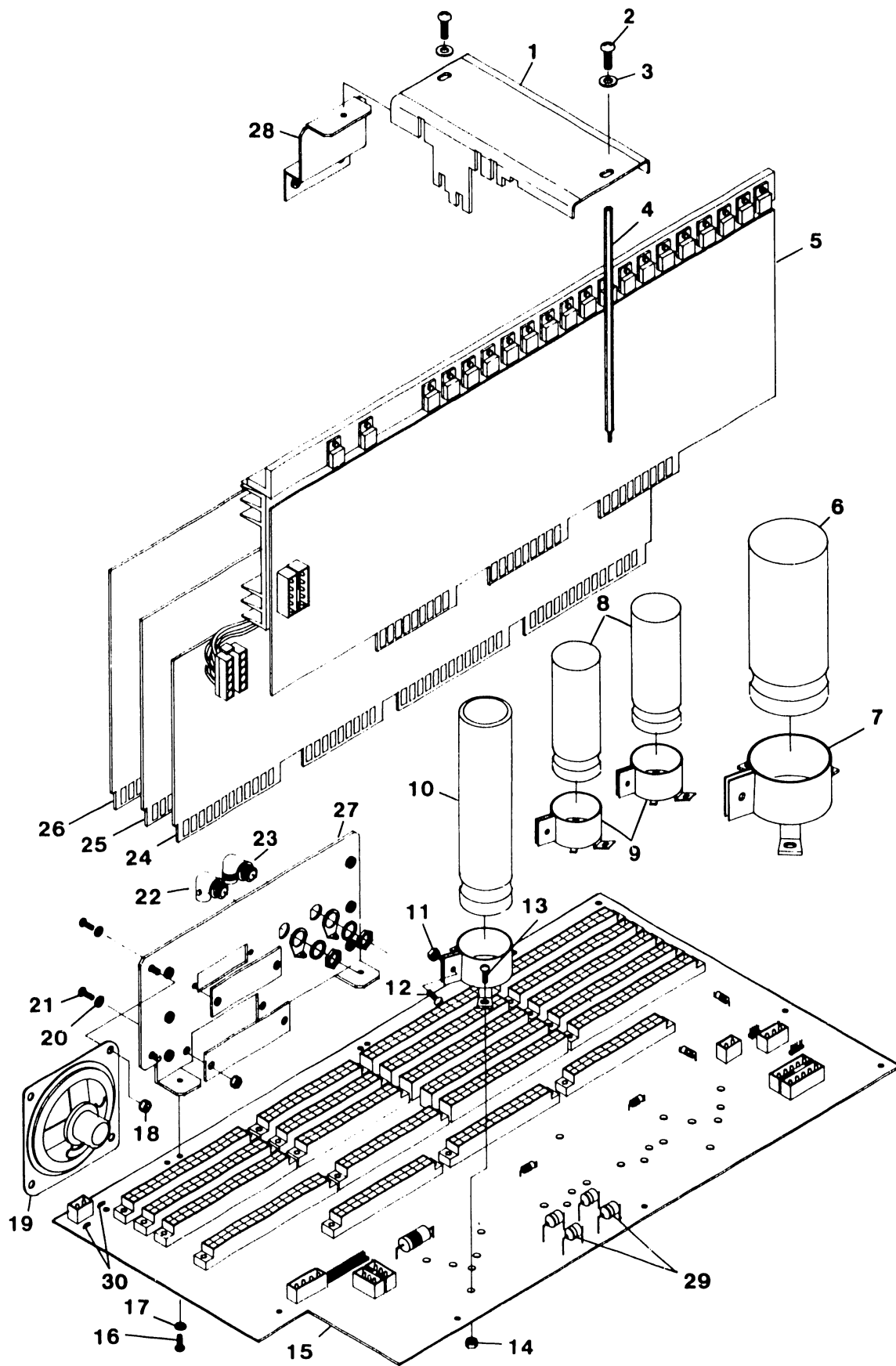

Figure 7-6 Motherboard Assembly

CHAPTER

8

**TROUBLE-
SHOOTING**

CHAPTER 8
TROUBLESHOOTING

8.1 INTRODUCTION

The chart on the following pages provide reference to common failures and solutions of error conditions common to 2233/2235 5533/5535 Dot Matrix Printers.

Table 8-1 Troubleshooting Chart

Symptom	Cause	Solution
Power On, no LED display	Power Fuse blown	Replace.
	+5 low	Check and adjust +5V.
	No voltage	Replace Pwr Driver PCB P/N (210-7594).
Missing Dots in character	Defective Pwr. transistor on Pwr Driver Board (P/N 210-7594).	Replace.
	Defective Print Head	Replace.
	Defective Print Head Cable	Replace.
	Defective ROM on CPU Board	Replace CPU Board (P/N 210-7593).
Print Quality light on one side.	Striker Bar Maladjusted	Adjust Striker Bar.
Print Quality light	Mechanical Adjustment	Perform Adjustment
	C3 on Motherboard	Replace C3.

Table 8-1 Troubleshooting Chart (cont'd)

Symptom	Cause	Solution
Characters do not line up when printing bidirectionally	Right Sensor out of Adjustment.	Adjust Right Sensor.
	Bad Index Sensor	Replace Encoder Amplifier P/N (210-7597).
	Incorrect Belt Tension	Adjust Belt tension.
Paper Streaked during print	Head penetration too close	Increase Head to Striker Gap.
	Paper not within usable specifications	See Appendix A, Paper Specifications.
	Paper solenoid dragging on paper	Replace Print Head.
	Paper Guide Out of Adjustment	Adjust Paper Guide.
No Column Strobe	Index To Home Sensor misadjusted	Adjust Index Sensor.
	Bad index Sensor	Replace Encoder Amplifier PCB P/N (210-7597).
	Defective Home Sensor	Replace Sensor Assy.
Not printing Bidirectionally	Printing Less than 80 characters	Expand printout to more than 80 columns.

APPENDIX

A

PAPER

SPECIFI-

CATIONS

APPENDIX A
Paper Specifications

Paper Size

Maximum width.....13.5 in. (34.3 cm)
Minimum width.....3.5 in. (8.9 cm)
Maximum number.....Four copies plus original

Paper Stock

Material.....Margin-perforated fan-fold card or paper stock
Single-part forms15-lb to 20-lb bond

For Multipart Forms

2-ply.....15/15-lb bond, 7-1b carbon
3-ply.....15/12/15-lb bond, 7-1b carbon
4-ply.....12/12/12/15-lb bond, 7-1b carbon
5-ply.....12/12/12/12/15-lb bond, 5-1b carbon
6-ply.....12/12/12/12/12/15-lb bond, 5-1b carbon

Fastening Multipart Forms

For improved forms handling, use glued margins. Otherwise, fasten with crimps along every two inches (5.1 cm) along both edges. Crimps must not come closer than 0.5 in. (1.3 cm) to the fanfold; each crimp must have four prongs--two to enter both form and carbon and two to enter forms only.

Forms Thickness

Maximum in print area.....0.018 in. (0.046 cm)
Over crimps in margin.....0.030 in. (0.076 cm)

When using forms with wide and narrow copies in the same set, the top copy should have the greatest width.

Sprocket Holes

Must run along both margins $0.25 + 0.03$ in. ($0.635 + 0.076$ cm) from paper edge to hole-center lines. Distance between hole centers must be $0.5 + 0.005$ in. ($1.27 + 0.0127$ cm) non-accumulative in any five inch (2.7 cm) length. Hole diameters must be $0.156 + 0.005$ in. ($0.396 + 0.0127$ cm); the two top and bottom drive holes (four per sheet) can be up to 0.2 in. (0.51 cm) in diameter to permit post or ring binding of output. Distance between hole-centers across the sheet must be uniform within 0.015 in. (0.038 cm) to a maximum of 12.31 in. (31.27 cm).

For preprinted forms, the pin-hole center in left margin cannot be less than 0.375 ± 0.0625 in. (0.95 ± 0.16 cm); pin-hole center in right margin cannot be less than 0.375 ± 0.0625 in. (0.95 ± 0.16 cm).

**APPENDIX
B
MODULE TEST
DESCRIPTIONS**

APPENDIX B
Module Test Descriptions

Test 1 - Data Buffer Test

This test is designed to send out different bit patterns in order to verify that all the available data lines are operating properly. The six different patterns are:

<u>BITS</u>	<u>HEX CODE</u>	<u>CHAR</u>
(1 through 6)	(3F)	(?)
(3, 4 & 7)	(4C)	(L)
(1,3,5 & 6)	(35)	(5)
(2,4,5 & 6)	(3A)	(:)
(4, 5 & 7)	(58)	(X)
(2, 3 & 6)	(26)	(&)
(1,3,5 & 7)	(55)	(U)

Test 2 - Spiral Pattern Test

This test is designed to check and verify that there is no interaction between the internal print buffer, the data bus, and other internal electrical interference associated with the desired print character. The routine prints all the printable characters (except for Hex 20 & 7F) on the printer in normal and expanded print in a spiral pattern.

Test 3 - Character Set Test

This test prints out all the printable characters (Hex 20-7F) using the normal print Font, Font 1 and Font 2 in both normal and expanded print. The Confidence Test (short version) prints out sixteen (16) characters per line. The QA Acceptance Test (long version) prints the hex code and then the character. The Font 2 Test will always be in 10 pitch because there is no 12 pitch in Font 2. The delete code (Hex 7F) is not printed, but *** DELETE CODE HEX (7F) *** should appear at the end of the Confidence Test and "(D/C)" should be printed at the end of the QA Acceptance Test.

Test 4 - Line Feed Test

This test is designed to verify the proper operation of the electrical and mechanical operation of the line feed portion of the printer. There are two sections to this routine. The first prints two line feeds (Hex OA's) and an asterisk (*) continually down the page to the end. The second section prints a Top Of Form reference line. Then line feeds are issued until the middle of the page is reached where a second reference line is printed. The same amount of line feeds are issued again and a third reference line is printed towards the bottom of the page.

Test 5 - Vertical Tabulation Test (Vertical Tabs)

This test is designed to verify the proper operation of the electrical, optical and mechanical functions of this printer. The routine issues a certain number of tab commands depending on which option of tests are being run. The end of the test will indicate how many lines apart they should be.

Test 6 - End of Document Test

This test is designed to verify the proper operation of the electrical, optical and mechanical functions of this printer. Because this printer does not have the EOD option, the page following this test must not be blank.

Test 7 - Vertical Tabulation Test (Skip To Channel)

This test verifies that the skip code, designed to skip to the next channel of the VFU, is functioning properly. Channel 1 is the Top Of Form and should be located at the top of the page. A skip to all twelve (12) channels will be performed. Depending on the lines per inch selected, the channels will be either four (4) or three (3) lines apart (one-half inch).

Test 8 - Vertical Tabulation Test (Skip to Line)

This test verifies that the code designed to skip a certain number of lines on the page is functioning properly. Reference lines will be printed one inch apart, filling the page.

Test 9 - Carriage Return Test

This test can verify in four different ways that the printer will handle and perform the appropriate action when a carriage return is required. In subtest 1, a line of data is printed and ends with a carriage return (Hex 0D). The second subtest will send the exact amount of characters to fill the print buffer and trigger the end of line actuator on the right side of the carriage. In the third subtest, again, enough characters are sent to actuate the end of line actuator, but a software carriage return will also be issued to see the results if both functions are applied. The result should be no blank lines. In the last subtest, more data is sent than the the buffer can normally handle. The extra characters should be lost and not printed out. *number*

Test 10 - Print Consistency Test

This test verifies that all the print head matrix pins are firing properly and in adequate time to produce a good quality print sample. A printable character is randomly selected and is sent to the printer. The operator should examine the sample to insure there is no problem with the print head.

Test 11 - Pin Firing Test

This test routine verifies that each of the nine (9) printer pins are firing correctly. A staircase pattern of dashes (-) is printed with vertical lines on each end. If a pin is missing, the operator needs only to count from the top of the step to the dash that is missing which will be the pin number.

Test 12 - Pitch Test

This test will ensure that the printer can switch character pitch at any time in normal and expanded print and return to the original pitch setting. The test prints four (4) different combinations of pitch settings to provide easy detection of a pitch error by the operator.

Test 13 - Quarter Line Feed Down Test

This test is designed to insure that the special line feed codes are functioning properly. The characters move down a quarter of a line. Three reference lines are printed on the left margin and two reference lines on the right. Words resembling their function will be issued the quarter line feed down code. The words should be 1/4, 1/2 and 3/4 of a line feed from reference line 2.

Test 14 - Line Feed Down Test

This test has three (3) subtests. Subtest 1 and 2 are designed to show the variable lengths of line feeds that are available. A reference line is printed and line feeds are issued in lengths of steps 1-4. Each step is 1/48 of an inch. Subtest 3 is designed to test the smallest amount of line feed that is available. Thirteen (13) dashes are printed followed by a line feed of one step. The line is repeated five (5) more times.

Test 15 - Variable Vertical Spacing Test

This test also insures that the variable line feed lengths are functioning properly. Four reference lines are printed in sequential order with the other characters utilizing the special features. The alphabet followed by the digits 0 - 9 and the letter E are printed in a variable vertical fashion.

The first four characters are each issued a quarter line feed and the fifth character will be on reference line 3. The next four characters are each issued a quarter line feed up code and the fifth character is printed on reference line 2. The test continues on in this manner until the end of text.

Test 16 - Line Feed Override & Underscoring Test

This test verifies that the special features of high and underscoring are functioning properly. This feature is tested in both normal and expanded code. The high lighting is achieved by overriding the same characters as many times as needed. The underscoring is done by issuing the hex code of the character and ORing it with hex code 80. The line "HIGH LIGHTING AND UNDERSCORING ARE AVAILABLE ON THIS PRINTER" should be printed. "HIGH LIGHTING" should be overridden five (5) times; "UNDERSCORING" should be underscored; "PRINTER" should be in expanded print and overridden four (4) times.

Test 17 - Expanded Pitch Test

This test verifies that when the print buffer is full of expanded characters, the next line will not be expanded (the expand attribute is dropped). A full line of A's, B's and C's are printed with the expanded code. Only the A's should be in expanded print.

Test 18 - Lines Per Minute Test

This test verifies that the timing and mechanical features affecting the speed of print are functioning properly. The operator must time the printing for one minute. A line of print and the line number are printed. The operator should get approximately 60 lines per minute.

Test 19 - Select/Deselect & Audio Alarm Test

This test performs two functions. First, it verifies that the printer does not lose characters when it is selected or deselected. Also, it tests the audio alarm. The line "OPERATOR MUST SELECT & DESELECT THIS PRINTER AT LEAST FIVE TIMES" is printed. After each line is printed, the audio alarm will sound.

Test 20 - Operator Clear Test

This test verifies that the clear function is working properly. The operator is instructed to deselect the printer, depress the 'CLEAR' button and reselect the printer. If the 'CLEAR' function is working, the operator will see "OPERATOR CLEAR TEST". If the function is not working, the operator will see "-E R R O R - I N OPERATOR CLEAR TEST".

Test 21 - Paper Out & Forms Override Test

This test insures that the two functions of "Forms Override" is functioning properly. The first is to detect when the printer is out of paper. The second function is to allow the operator to print additional material, even though the printer is out of paper. The operator is instructed to deselect the printer, depress "Line Feed" until the "Forms Override" button illuminates. Then, the operator should reselect the printer, depress "Return/Exec" on the CRT and then depress "Forms Override" three times. The operator will see "ERROR IF NOT AT BOTTOM OF THE PAGE/FORMS OVERRIDE TEST COMPLETED".

APPENDIX

C

PRINTER CONTROL

CODES MODELS

2233 / 2235

APPENDIX C
Printer Control Codes Models 2233/2235

C.1 INTRODUCTION

The following paragraphs provide a description of the Basic statements employing hex-coded characters to control device selection and the methods used to format printer output of the 2233/2235 Dot Matrix Printers. This information is provided from the Model 2233 User Manual Doc. # 700-6854 and 2235 Line Printer User Manual Doc. # 700-6816. Refer to Table 5-3 of this Appendix to reference the hex coded characters supported by the 2233/2235 Dot Matrix Printers.

Refer to the following Chapters for more detailed information:

Chapter 2	Device Selection
Chapter 3	Formatting Output
Chapter 4	Printer Control Codes
Chapter 5	Direct Access Vertical Format Unit

C.2 HEX FUNCTIONS

The HEX function is used within the BASIC program to output any character or function within the ASCII character set (refer to Appendix A of the User Manual). Hex codes are also used to control vertical tabulation of the printer output from within a BASIC program regardless of the vertical formatting device chosen by the user. In addition, HEX codes are used to load the Direct Access Vertical Format Unit (DAVFU).

CHAPTER 2
 DEVICE SELECTION

2.1 THE SELECT STATEMENT

The **SELECT** statement must be used by the operator to select the Model 2235 as the output device. A **SELECT** statement can be used either in the Immediate mode or as a statement within a program. When used to select the Model 2235, the **SELECT** statement requires a **PRINT**, **LIST** or, **CO** command and a 3-digit Device Address code (xyy) consisting of a Device Type (x) and a Unit Address code (yy). Line Length can also be specified in the **SELECT** statement. Each of the parameters of the **SELECT** statement is described in the following example.

Example 1 (SELECT Statement):

```

100 SELECT PRINT 215 (132) .
Device Type-----↑
Unit Address-----↑
Line Length-----↑
  
```

If line length is not specified in a **SELECT** statement, the line length defaults to 80 characters, the standard width of the Cathode Ray Tube (CRT). In a system with a 64-column CRT, the line length defaults to 64 characters.

Example 2 (SELECT Statement):

```
SELECT PRINT 215 (132)
```

```

10 PRINT "*****THE MODEL 2235 LINE PRINTER
PRINTS 132 CHARACTERS PER LINE WHEN 10-PITCH IS SELECTED!*****"
*****"
RUN
  
```

Output (reduced):

```

*****THE MODEL 2235 LINE PRINTER PRINTS 132 CHARACTERS PER LINE WHEN 10-PITCH IS SELECTED!*****
*****
  
```

Device Type

The system uses the Device Type digit in the Device Address code to identify the I/O class for a device and to specify control procedures for communicating with that device. Since the various peripheral devices used in a system often require different control procedures to perform an input/output operation, the programmer must indicate to the system which type of I/O device is being used.

The Model 2235 automatically prints the characters in the buffer and executes a carriage return at the end of a line (132 10-pitch characters or 158 12.2-pitch characters). After the printer responds to the carriage return command, it automatically executes a line feed.

Because Device Type 2 addresses devices that automatically execute a line feed after a carriage return, this device type is normally used in statements selecting the Model 2235 for output. When this device type is specified, printer output is single-spaced.

Example (Device Type 2):

```
10 SELECT PRINT 215 (80)
20 FOR R = 1 TO 5
30 PRINT "MODEL 2235 OUTPUT AS DEVICE TYPE 2"
40 NEXT R
RUN
```

Output:

```
MODEL 2235 OUTPUT AS DEVICE TYPE 2
MODEL 2235 OUTPUT AS DEVICE TYPE 2
MODEL 2235 OUTPUT AS DEVICE TYPE 2
MODEL 2235 OUTPUT AS DEVICE TYPE 2
MODEL 2235 OUTPUT AS DEVICE TYPE 2
```

Device Type 0 usually addresses a device that does not automatically execute a line feed after a carriage return: for example, a CRT. When used, this device type causes a line feed after each carriage return executed by the printer. Since the Model 2235 itself also generates a line feed after a carriage return, when selected with Device Type 0, the printed output is double-spaced.

Example 2 (Device Type 4):

```
SELECT PRINT 415 (124)
10 FOR B = 1 TO 5
20 PRINT "AABBCC"
30 PRINT HEX(OD)
40 NEXT B
RUN
```

Output:

```
AABBCC
AABBCC
AABBCC
AABBCC
AABBCC
```

Refer to Section 2.3 for information on special printing techniques available by selecting the printer with various Device Type codes.

Unit Address

When the Model 2235 is used as a system printer, it is attached to the printer controller board installed in the system CPU, and usually assigned Unit Address 15. If a second Wang printer is used as a system printer on the same CPU, it is usually assigned Unit Address 16 by the Wang Service Representative who installs the system.

If the Model 2235 is used as the local printer of a Model 2236DE Interactive Terminal, it is attached directly to the rear panel of the terminal and may be accessed at Unit Address 04 (for example, SELECT PRINT 204).

Line Length

The Line Length parameter is an optional parameter in a SELECT PRINT, SELECT LIST, or SELECT CO statement. This parameter specifies the number of characters to be sent to the printer before the system issues a carriage return and resets the internal line count. The user normally varies the line length to accommodate paper of different widths.

The maximum number of characters per line that can be printed on the Model 2235 is either 132 or 158, depending on pitch selection (10-pitch or 12.2-pitch). In the SELECT statement, line length is indicated in the parentheses following the 3-digit Device Address code. For example:

SELECT PRINT 215 (158)	Selects the Model 2235 for printing operations and sets the line length to 158.
SELECT LIST 215 (132)	Selects the Model 2235 for listing operations and sets the line length to 132.
SELECT CO 215 (80)	Selects the Model 2235 for console output and sets line length to 80.

If a line length is not specified for PRINT, LIST, or CO operations, either the default line length or the last line length selected for each of these operations is used. Note that the default line length set during Master Initialization is 80 characters. The maximum line length specified in a SELECT statement is 255. However, the use of a line length greater than 132 (10-pitch) or 158 (12.2 pitch) is not recommended. A longer line count typically produces two carriage returns: one performed automatically by the printer when a full line of characters has been printed, and another issued by the system when the line count specified in the SELECT PRINT statement is exceeded.

Example (Line Length Greater than 132 at 10-pitch):

```
10 REM EXAMPLE OF USING A LINE LENGTH GREATER THAN 132 CHARACTERS
AT 10-PITCH
20 SELECT PRINT 215 (132)
30 PRINT "HENCE, LOATHED MELANCHOLY / OF CERBERUS AND BLACKEST
MIDNIGHT BORN / IN STYGIAN CAVE FORLORN / 'MONGST HORRID SHAPES, AND
SHRIEKS, AND SIGHTS UNHOLY!"
RUN
```

Output (reduced):

```
HENCE, LOATHED MELANCHOLY / OF CERBERUS AND BLACKEST MIDNIGHT BORN / IN STYGIAN CAVE FORLORN / 'MONGST HORRID SHAPES, AND SHRIEKS, AN
D SIGHTS UNHOLY'
```

The CPU uses the Line Length parameter to generate an automatic carriage return when a line exceeds the specified line length and no carriage return has been supplied by the program. The CPU maintains a tally of the number of characters sent to the printer (line count). If this line count equals the current value of the line length before the output line is complete, the CPU issues a carriage return command to the printer and resets the line count to zero. The printer continues the interrupted output on the next line.

Example 1 (Line Length Less than Number of Characters in Print Line):

```
5 REM EXAMPLE OF USING A LINE LENGTH LESS THAN THE MAXIMUM NUMBER
OF CHARACTERS IN THE PRINT LINE
10 SELECT PRINT 215 (5)
20 PRINT "THE MODEL 2235 PRINTS UP TO 158 CHARACTERS PER LINE
RUN
```

Output:

```
THE M
ODEL
2235
PRINT
S UP
TO 15
8 CHA
RACTE
RS PE
R LIN
E
```

Example 2 (Line Length Less than Number of Characters in Print Line):

```
SELECT PRINT 215 (20)
10 PRINT "ABCDEFGHJKLMNOPQRSTUVWXYZ"
RUN
```

Output:

```
ABCDEFGHIJKLMNQRST
UVWXYZ
```

When the system receives a PRINT statement with no trailing comma or semicolon, it executes a carriage return after the contents of the printer buffer are printed. If the line count has not yet reached the line length specified in the SELECT statement, the system automatically resets the line count to zero for the start of a new line.

Example (PRINT Statement with No Punctuation):

```
10 REM EXAMPLE OF PRINT STATEMENTS WITH NO TRAILING COMMA OR
SEMICOLON
20 SELECT PRINT 215 (30)
30 PRINT "BUY"
40 PRINT "CHEESE!"
RUN
```

Output:

```
BUY
CHEESE!
```

The line count is reset to zero under any one of the following conditions.

- . The line count equals the line length.
- . A SELECT PRINT statement is executed.
- . A CLEAR command is executed.
- . A PRINT, PRINTUSING, or HEXPRINT statement is executed.
- . The system is reset.
- . The system is master initialized.

2.2 SELECTING THE PRINTER

Print

SELECT PRINT 215

This statement selects the printer at Device Address 215 for all PRINT, PRINTUSING, or HEXPRINT statements entered in Program mode. All subsequent printed output is generated by the system printer until another device is selected.

NOTE

When your system is first turned on, print operations are seen on the CRT, the primary device for such operations. Therefore, it is necessary to execute a SELECT statement to direct the output of PRINT statements to the printer.

The SELECT PRINT statement can be entered as a program statement or independently as an Immediate mode statement.

Example 1 (Program Mode SELECT):

```
10 SELECT PRINT 215
20 PRINT "X", "2X"
30 FOR X = 1 TO 50 STEP 10
40 PRINT X, X*2
50 NEXT X
```

Example 2 (Immediate Mode SELECT):

```
SELECT PRINT 215
10 PRINT "X", "2X"
20 FOR X = 1 TO 50 STEP 10
30 PRINT X, X*2
40 NEXT X
```

When either of these programs is executed, the printed output is:

X	2X
1	2
11	22
21	42
31	62
41	82

NOTE

Though the printer is selected for printed output with SELECT PRINT 215, printout resulting from PRINT statements entered in the Immediate mode will still appear on the CRT unless the printer is selected for console output (refer to the Console Input section).

List

SELECT LIST 215

The default address for LIST operations is 005, the CRT. The SELECT LIST 215 statement, entered in Immediate mode, selects the printer at Device Address 215 for all program listing operations.

Example (Selecting the Printer for Listing):

```
SELECT LIST 215
5 DIM A$52
17 REM AN EXAMPLE USING THE PRINTER FOR LISTING
20 A$="THE MODEL 2235 PRINTER CAN BE SELECTED FOR LISTING."
30 PRINT A$
999 END
LIST
```

Output:

```
5 DIM A$52
17 REM AN EXAMPLE USING THE PRINTER FOR LISTING
20 A$ = "THE MODEL 2235 PRINTER CAN BE SELECTED FOR LISTING"
30 PRINT A$
999 END
```

Console Output

SELECT CO 215

This statement selects the printer at Device Address 215 for all console output operations. Console Output includes all system displays, such as the READY message; output from STOP and END statements; any data keyed in on the keyboard and entered into the CPU; and all output from Immediate mode operations, TRACE statements, and error messages.

NOTE

On 2200 multi-user systems such as the 2200MVP and 2200LVP, all Console Output (CO) operations are always directed to the CRT (Device Address 005). On these systems, when the printer is selected for Console Output, TRACE output alone is sent; all other CO operations remain directed to the CRT.

As an example, enter the following command in Immediate mode.

```
SELECT CO 215
```

Press the RETURN key, then the RESET key. The following appears on the printer.

```
:READY
```

Subsequently, all information entered into the CPU via the keyboard will be printed on the printer.

2.3 SPECIAL TECHNIQUES

Device Type 2 is usually used with the Model 2235. When the printer is selected with this Device Type for LIST, PRINT, or CO operations, normal single-spaced output is produced. Device Type 0 can also be used with the Model 2235 to obtain double-spaced output. Carriage returns followed by line feeds are initiated by the CPU at the end of each program text line as well as whenever the line count equals the selected line length. After the Model 2235 executes a carriage return, it supplies another line feed, producing the double spacing after each printed line.

Example (Double Spacing Using Device Type 0):

```
SELECT LIST 015
10 FOR E = 1 TO 10
20 PRINT "AAAAAAAAAABBBBBBBBBBCCCCCCCCDDDDDDDDDEEEEEEEEE
FFFFFFFPGGGGGGGGGHHHHHHHHHIIIIIIIIJJJJJJJKKKKKKKK?"
30 NEXT E
LIST
```

Output:

```
10 FOR E = 1 TO 10
20 PRINT "AAAAAAAAAABBBBBBBBBBCCCCCCCCDDDDDDDDDEEEEEEEEEFFFFFFFPGGGGGGGGG
HHHHHHHHHIIIIIIIIJJJJJJJKKKKKKKK?"
30 NEXT E
```

Although Device Type 4 is intended for use with Wang plotter peripherals, it has limited application with other types of peripherals. Device Type 4 can be of use with the Model 2235 Line Printer to produce double-spaced program listings. When listing a program with Device Type 4, a program statement overlapping onto more than one print line is single-spaced; however, each new program statement is double spaced. Thus, a more readable double-spaced output is achieved with Device Type 4. However, with this exception, it is recommended that the Model 2235 normally be selected with Device Type 2 or 0. For normal printing of a program output Device Type 4 should not be used.

CHAPTER 3 FORMATTING OUTPUT

3.1 INTRODUCTION

Several methods of formatting output are available to the Model 2235 Line Printer. These include use of a variety of Hexadecimal codes to control such functions as carriage return and margin setting and a Direct Access Vertical Control Unit to control full page format. These methods will be discussed in detail in Chapters 4 and 5. Chapter 3 discusses formatting using the PRINT command and variations (PRINT, PRINTUSING, and HEXPRINT) and the Tab function.

3.2 PRINT, PRINTUSING, AND HEXPRINT STATEMENTS

The PRINT, PRINTUSING, and HEXPRINT statements are used with the Model 2235 in the same manner as the CRT. However, whereas the CRT provides only five 16-character print zones per line, the printer provides over eight.

Zoned Format

When selected for 10-pitch output, the Model 2235 has a line length of 132 characters, divided into 8 zones of 16 characters each, and 1 zone of 4 characters. The zones constitute columns 0-15, 16-31, 32-47, 48-63, 64-79, 80-95, 96-111, 112-127, and 128-131, respectively.

When selected for 12.2-pitch, the Model 2235 has a line length of 158 characters, divided into 11 zones of 16 characters each and 1 zone of 12 characters. The zones constitute columns 0-15, 16-31, 32-47, 48-63, 64-79, 80-95, 96-111, 112-127, 128-143, and 144-157, respectively.

If commas separate elements in a PRINT statement, each element begins a new zone. When the system encounters a comma preceding a print element, it outputs spaces until reaching the first character position of the next zone and then outputs the value of the print element starting at that position.

Example (Printing in Zoned Format with Commas):

```
20 SELECT PRINT 215 (132)
30 PRINT "COLUMNS 0-15", "COLUMNS 16-31", "COLUMNS 32-47"
RUN
```

Output:

```
COLUMNS 0-15    COLUMNS 16-31    COLUMNS 32-47
```

Example (Skipping over Zones with Commas):

```
20 SELECT PRINT 215 (132)
30 PRINT "ACCOUNT NO.",,,,"BALANCE DUE"
40 PRINT "(COLUMNS 0-15)",,,,"(COLUMNS 48-63)"
50 PRINT 10082,,,153.19
:UN
```

Output:

ACCOUNT NO.	BALANCE DUE
(COLUMNS 0-15)	(COLUMNS 48-63)
10082	153.19

NOTE

In zone printing on the Model 2235, ensure that the last zone does not exceed the legal length (either 4 or 12 characters depending on pitch selection). For instance, in a 10-pitch format, if the information for the last zone exceeds 4 columns, then the information is printed in the first zone of the next line.

Example:

```
10 SELECT PRINT 215 (124)
20 PRINT "NO.",1.2,3.4,5.6,7.8,9.0,8.4,10.2,"BALANCE DUE
NOW"
RUN
```

Output (reduced):

NO.	1.2	3.4	5.6	7.8	9	8.4	10.2
BALANCE DUE NOW							

In the previous example, the ninth element in Line 20 exceeded four characters in length and thus was printed in the next line.

Packed Format

If semicolons separate elements in a PRINT statement, the output appears in a packed format, with no spaces between items. In packed format, no additional blanks are added to the print line; blanks in the print line occur only when they are an intrinsic part of an alpha or numeric value.

Example 1 (Packed Format):

```
SELECT PRINT 215
10 A=1234: B = -5678
20 PRINT "ABC"; "DEF"
30 PRINT A; B
RUN
```

Output:

```
ABCDEF
1234 -5678
```

Example 2 (Packed Format):

```
20 SELECT PRINT 215 (132): DIM A$18
30 A$= " CARDBOARD CHALET": P$= " $53,000"
40 PRINT "STYLE: "; A$; " PRICE: "; P$
RUN
```

Output:

```
STYLE: CARDBOARD CHALET PRICE: $53,000
```

NOTE

A semicolon at the end of a PRINT statement suppresses the normal line feed at execution.

Example 3 (Packed Format):

```
10 SELECT PRINT 215
20 PRINT "FAR-";
30 PRINT "OFF"
RUN
```

Output:

```
FAR-OFF
```

Example (Formatting with PRINT USING Statement):

```
20 SELECT PRINT 215 (132): DIM A$18
30 A$= "CARDBOARD CHALET": P=53000
40 PRINT USING 50, A$,P
50 % STYLE: ##### PRICE: $##,###
RUN
```

Output:

```
STYLE: CARDBOARD CHALET PRICE: $53,000
```

Example (HEXPRINT Statement):

```
20 SELECT PRINT 215 (132)
30 A$="ABC DEF GHI JKL"
40 HEXPRINT A$
RUN
```

Output:

```
4142432044454620474849204A4B4C
```

PRINTUSING Statement

To print columns of information across a line, or print numeric and/or alphanumeric values according to an exact image, the PRINTUSING statement can be used to specify the print format. For a complete discussion of the PRINTUSING statement, refer to the Wang BASIC-2 Language Reference Manual.

Example 1 (PRINTUSING Statement):

```
10 X=1: Y=2: Z=3
20 PRINTUSING 30, X; Y; Z
30 % #.#
RUN
```

Output:

```
1.0 2.0 3.0
```

Example 2 (PRINTUSING Statement):

```
100 PRINTUSING 200
200 % PROFIT AND LOSS STATEMENT
RUN
```

Output:

```
PROFIT AND LOSS STATEMENT
```

Example 3 (PRINTUSING Statement):

```
50 A$="H. CASTORP --": T=9237.51
100 PRINTUSING 200, A$, T
200 % SALESMAN ##### TOTAL SALES $$$,###.##
RUN
```

Output:

```
SALESMAN H. CASTORP TOTAL SALES $9,237.51
```

Example 4 (PRINTUSING Statement):

```
10 X=2.3: Y=27.123
20 PRINTUSING 30, X, Y
30 % ANGLE -####.##### LENGTH = +##.#
RUN
```

Output:

```
ANGLE          2.300000 LENGTH = +27.1
```

3.3 THE TAB FUNCTION

The Tab function has the following format:

TAB(xx);

where: xx = an integer, variable, or expression representing a number of character positions

The Tab function can be used to position the print location prior to typing a character. When a PRINT statement containing a Tab function is executed, the Model 2235 skips to the column specified by the integer portion of the Tab function, and then prints the indicated argument.

Example 1 (Tab Function):

```
SELECT PRINT 215(132)
10 PRINT TAB(49);"MASTER SEWERAGE PLAN"
20 PRINT: PRINT
30 PRINT TAB(14);"STREET";TAB(44);"LINE FEET";
   TAB(84);"PIPE DIA.";TAB(104);"CONNECTIONS"
RUN
```

Output (reduced):

```
MASTER SEWERAGE PLAN

STREET          LINE FEET          PIPE DIA.          CONNECTIONS
```

In the previous example, MASTER SEWERAGE PLAN is printed starting at Column 75; likewise, the headings in Line 30 are printed at the specified tab settings.

If the value of the TAB(x); expression is greater than the selected line length, the printer moves to the next line and completes the PRINT statement starting at Column 0.

Example 2 (Tab Function):

```
10 SELECT PRINT 215
20 A=25
30 PRINT TAB(A);"TANK MODEL";TAB(3*A);"CREW SIZE"
RUN
```

Output:

```
          TANK MODEL
CREW SIZE
```

NOTE

If the carriage position in the line being printed is greater than the TAB(); argument, the tab is ignored. For example, in the following statement the TAB(5); is ignored.

```
10 PRINT "123456789"; TAB(5); "No."
```

When using the Tab function to print numeric values in column format, an additional column to the left of the value is allocated for the sign (+ or -). If this column is not used for positive numbers, actual printing begins at column after the column specified in the function.

Example (Sign Column):

```
10 SELECT PRINT 215 (80)
20 PRINT TAB(10);"POWER";TAB(20);"VALUE"
30 FOR N=-1 TO 10
40 PRINT TAB(10);N;TAB(20);(-2) N
50 NEXT N
RUN
```

Output:

POWER	VALUE
-1	-.5
0	1
1	-2
2	4
3	-8
4	16
5	-32
6	64
7	-128
8	256
9	-512
10	1024

CHAPTER 4 PRINTER CONTROL CODES

4.1 THE HEX FUNCTION

The Hex function is used within the BASIC program to output any character or function within the ASCII character set (refer to Appendix A). Hex codes are also used to control vertical tabulation of output from within a BASIC program, regardless of the vertical formatting device chosen by the user. In addition, Hex codes are used to load the Direct Access Vertical Format Unit (DAVFU).

Character Codes

The Hex function is used in a BASIC program to output characters on the printer (both those that do and do not appear on the standard keyboards) or to execute special printer control codes. The Hex function has the following format.

HEX(hh[hh][..])

Each h equals a Hex digit (0--9) or letter (A--F). An even number of characters must always appear in a Hex function; spaces are not allowed. Refer to Appendix A for a complete listing of Hexadecimal character codes and control codes.

Hex codes for characters and/or printer control can be combined. For example, enter and run the following program.

```
10 SELECT PRINT 215
20 PRINT HEX (410DOA42)
RUN
```

Since the character code for A is HEX(41) and for B is HEX(42), and the control codes for carriage return and line feed are HEX(0D) and HEX(0A) respectively, the following is printed.

A

E

Control Codes

When the Model 2235 receives a Hex code for a printable character, it simply places the code into the print buffer. Unless the buffer is full, no immediate action is taken. However, certain special Hex codes do not enter the buffer, but instead cause immediate action by the printer. These special codes are the printer control codes.

NOTE

When Hex codes are combined in a single statement line, most control codes are executed before character codes.

Several features of the Model 2235 printer have been defined in terms of multi-character control code sequences beginning with HEX(02) and ending in a HEX(OE) or HEX(OF). These code sequences enable, turn on and off, and disable certain attributes and functions in a manner similar to that used by the 2236DE and 2236DW terminals.

4.2 LINE FEED CONTROL CODES

Automatic Line Feed/Line Feed Size Control

When powered on, or when a Power-On Reset control sequence [HEX(020D0C030F)] is executed, the Model 2235 defaults to an automatic line feed of six lines per inch after a carriage return. However, several codes are provided to the programmer to suppress or enable the automatic line feed, with or without altering the line feed size.

Automatic line feed can be disabled by the sequence HEX(020A0F) without changing the currently selected line feed size. Subsequently, use of the sequence HEX(020A0E) will enable the automatic line feed without changing the currently selected line feed size.

Line feed size, conversely, can be altered while suppressing or enabling the automatic line feed function. Line feed size can be set to either six or eight lines per inch using the following control codes.

HEX(020A0101060E) or HEX(020A0101060F) for 6 lines per inch

where: OE = enable automatic line feed
OF = suppress automatic line feed

HEX(020A0101080E) or HEX(020A0101080F) for 8 lines per inch

where: OE = enable automatic line feed
OF = suppress automatic line feed

NOTE

The printer executes these sequences before printing unprinted data that may be in the line buffer.

Changing line feed size has a direct effect on the DAVFU. When changing line feed size, it is necessary to load an appropriate VFU format before attempting to print. As a result, line feed size cannot be changed within a page. The user should first execute a top-of-form command before loading the proper VFU and setting the corresponding line feed size.

Example (Changing Line Feed Size/Controlling Automatic Carriage Return):

```
10 REM TOP OF FORM: PRINT HEX(0C)
20 REM LOAD VFU CREATED BY VERTICAL FORMAT CONTROL UTILITY
30 DIM T$(128)2
40 DATA LOAD DC OPEN T "SAMPLE": REM "SAMPLE" = NAME OF VFU FILE
50 DATA LOAD DC T$( )
60 $GIO/204, (A000,G$) T$( ): REM "204" IS PRINTER ADDRESS
70 REM SELECT 8 LPI, ENABLE AUTO LINE FEED: PRINT HEX(020A0101080E)
80 FOR X = 1 TO 10: PRINT "THE TRAJECTORY OF THE ELECTRON":NEXT X
90 REM DISABLE LINE FEED: PRINT HEX(020A0F)
100 FOR X = 1 TO 10: PRINT "by M. R. Fox": NEXT X
RUN
```

Output:

```
THE TRAJECTORY OF THE ELECTRON
THE TRAJECTORY OF THE ELECTRON
THE TRAJECTORY OF THE ELECTRON
THE TRAJECTORY OF THE ELECTRON
THE TRAJECTORY OF THE ELECTRON
THE TRAJECTORY OF THE ELECTRON
THE TRAJECTORY OF THE ELECTRON
THE TRAJECTORY OF THE ELECTRON
THE TRAJECTORY OF THE ELECTRON
THE TRAJECTORY OF THE ELECTRON
by M. R. Fox
```

Line Feed: HEX(0A)

The Line Feed control code advances the paper one line. Line feed codes embedded within a print line are executed before the data in that line is printed.

Example (Line Feed):

```
10 PRINT "WATCH"; HEX(0A); "YOUR"; HEX(0A); "STEP"
RUN
```

Output:

```
(2 line feeds)
WATCHYOURSTEP
```

Partial Line Feed: HEX(020Add0F)

The Partial Line Feed command control sequence allows the programmer to define partial line feed increments. This feature enables the printing of superscripts and subscripts. The sequence has the following format.

HEX(020Add0F)

where: dd = 00 for no line feed
02 for 1/4 line feed
04 for 1/2 line feed
08 for 3/4 line feed

This sequence, when embedded in a print line, is executed before any data is printed. Whenever a normal line feed is executed after a partial line feed, the paper is moved to the start of the next line feed position. For example, if the sequence HEX(020A080F) has caused a feed of 3/4 line, the next full line feed command would move the platen the remaining 1/4 line. When using this sequence to print superscripts and subscripts, it is necessary to first disable the automatic line feed feature.

Example (Partial Line Feed):

```
10 SELECT PRINT 204
20 PRINT "THE EQUATION FOR Z IS:"
30 REM SUPPRESS AUTO LINE FEED: PRINT HEX(020A0F)
40 REM PRINT SUPERSCRIPTS: PRINT "  2  2"
50 REM ADVANCE 1/2 LINE: PRINT HEX(020A040F)
60 REM PRINT BASE LINE: PRINT "Z = X + Y - 2*(X+Y)"
70 REM ADVANCE 1/2 LINE: PRINT HEX(020A040F)
80 REM PRINT SUBSCRIPTS: PRINT "  3"
90 REM REACTIVATE AUTO LINE FEED: PRINT HEX(020A0E)
100 REM MOVE TO NEXT FULL LINE POSITION: PRINT
110 REM PRINT NEXT LINE: PRINT "TO CONTINUE WITH THIS LINE OF THOUGHT"
```

Output:

```
THE EQUATION FOR Z IS:
Z = X22 + Y2 - 2*(X+Y)
TO CONTINUE WITH THIS LINE OF THOUGHT
```

4.3 ENHANCED PRINTED OUTPUT

The Model 2235 employs three methods of enhancing printed output: underscore, horizontal expansion, and a combination of both of these. The means used to specify the method of enhancing output is similar to that used with the 2236DE display terminal. The same control code sequence beginning with HEX(02) can be used to specify enhanced output for both the Model 2235 Line Printer and the Model 2236DE terminal.

The control code sequence has the following format.

HEX(0204nnaabb0E) or HEX(0204nnaabb0F)

where: nn = any Hex value

aa = 00 to disable underscore
04 or
0B to enable underscore

bb = 00 to disable expanded print
02 or
0B to enable expanded print

0E = enable attributes defined by nn, aa, and bb immediately; do not disable attributes until an isolated HEX(0F) code, a Power-On Reset sequence, or another select attribute sequence is received

0F = activate attributes defined by nn, aa, and bb only upon receiving an isolated HEX(0E) code; disable attributes when an isolated HEX(0F) or HEX(0D) code is received

The flexibility of this control code sequence in enabling and disabling a combination of the underscore and expanded print attributes is illustrated in the following sections.

Underscore

A HEX(02040004000E) or HEX(0204000B000F) sequence immediately turns on the underscore attribute and leaves it on until an isolated HEX(0F) is executed.

Example (Immediate Use of Underscore):

```
10 PRINT HEX(02040004000E)
20 PRINT "THE LAZY DUCK"
30 PRINT "JUMPS OVER THE"
40 PRINT HEX(0F); "QUICK BLACK DOG."
RUN
```

Output:

```
THE LAZY DUCK
JUMPS OVER THE
QUICK BLACK DOG
```

A HEX(02040004000F) or HEX(0204000B000F) sequence, however, will not immediately turn on the underscore attribute. Instead, underscore is turned on only when the printer receives an isolated HEX(OE) code. The attribute is turned off by either an isolated HEX(OF) code or a carriage return [HEX(0D)].

Example (Underscoring Individual Lines):

```
10 PRINT HEX(02040004000F)
20 PRINT "THE VIKINGS SAILED"
30 PRINT HEX(OE); "IN OCEAN-GOING CARGO SHIPS"
40 PRINT "CALLED KNORRS."
RUN
```

Output:

```
THE VIKINGS SAILED
IN OCEAN-GOING CARGO SHIPS
CALLED KNORRS.
```

Example (Underscoring Partial Lines):

```
10 PRINT HEX(02040004000F)
20 PRINT "THE ISLAND OF"; HEX(OE); "MALTA"; HEX(OF); "RECEIVES
LITTLE RAINFALL DURING"
RUN
```

Output:

```
THE ISLAND OF MALTA RECEIVES LITTLE RAINFALL DURING
```

Either implementation of the underscore attribute may be turned off by execution of a disable underscore code sequence [i.e., HEX(02040000000E)]. This sequence, in addition to turning off the underscore feature, redefines HEX(OE) and HEX(OF) as null codes, causing the printer to ignore an isolated HEX(OE) or HEX(OF) until the attribute is again enabled.

Expanded Print

The "bb" portion of the control code sequences described previously for the underscore feature is used to select expanded print. This attribute is controlled in exactly the same manner as the underscore feature. When selected for expanded print, the Model 2235 prints a line of up to 66 expanded (double-width) characters at 10-pitch or up to 79 expanded characters at 12.2-pitch.

A HEX(02040000020E) or HEX(020400000B0E) sequence immediately turns on the expanded print attribute and leaves it on until an isolated HEX(0F) is executed.

Example (Immediate Use of Expanded Print):

```
10 PRINT HEX(02040000020E)
20 PRINT "FRIENDLY"
30 PRINT "PHARMACY"
40 PRINT HEX(0F); "J. Jones, Prop."
RUN
```

Output:

```
FRIENDLY
PHARMACY
J. Jones, Prop.
```

A HEX(02040000020F) or HEX(020400000B0F) sequence does not immediately turn on the expanded print attribute. Instead, expanded print is turned on only when the printer receives an isolated HEX(0E) code. This use of the HEX(0E) code is identical to its implementation when the printer is powered on. When the printer is powered on or when a Power-On Reset code sequence [HEX(020D0C030F)] is issued, an isolated HEX(0E) code turns on expanded print. The expanded print attribute may be turned off by either an isolated HEX(0F) code or a carriage return [HEX(0D)].

Example (Expanding Individual Lines):

```
10 PRINT HEX(02040000020F)
20 PRINT "MICROTUBULES ARE PRESENT IN EVERY"
30 PRINT HEX(0E); "EUKARYOTIC (Nucleated)"
40 PRINT "CELL"
RUN
```

Output:

```
MICROTUBULES ARE PRESENT IN EVERY
EUKARYOTIC (Nucleated)
CELL
```

Example (Expanding Partial Lines):

```
10 PRINT HEX(02040000020F)
20 PRINT HEX(OE); "ANDEAN BEANS,"; HEX(OF); " HOWEVER, ARE
SNOW-COVERED THE ENTIRE"
RUN
```

Output:

```
ANDEAN BEANS, HOWEVER, ARE SNOW-COVERED THE ENTIRE
```

Either implementation of the expanded print attribute may be turned off by execution of a disable underscore code sequence [i.e., HEX(02040000000E)]. This sequence, in addition to turning off the expanded print feature, redefines HEX(OE) and HEX(OF) as null codes, causing the printer to ignore an isolated HEX(OE) or HEX(OF) until the attribute is again enabled.

Both Underscore and Expanded Print

Both the underscore and expanded print attributes can be activated in a similar manner. The code sequences HEX(02040004020E) or HEX(02040004020F) [and HEX(0204000B0B0E) or HEX(0204000B0B0F)], respectively, select both attributes to be activated as described previously.

Either attribute may be turned off and disabled by execution of the appropriate disable attribute code. Execution of a HEX(02040000020E) sequence disables the underscore attribute only. Execution of a HEX(02040002000E) sequence disables the expanded print attribute only.

Example (Use of Both Underscore and Expanded Print):

```
10 PRINT HEX(02040004020F)
20 PRINT HEX(OE); "THIS LINE IS UNDERSCORED AND EXPANDED"
30 PRINT HEX(02040000020E)
40 PRINT "THIS LINE IS EXPANDED ONLY"
50 PRINT "THIS "; HEX(OF); "LINE BEGAN AS EXPANDED"
RUN
```

Output:

```
THIS LINE IS UNDERSCORED AND EXPANDED
THIS LINE IS EXPANDED ONLY
THIS LINE BEGAN AS EXPANDED
```

4.4 MISCELLANEOUS CONTROL CODES

Audio Alarm: HEX(07)

The Audio Alarm code generates an audible tone about one second in duration.

Example (Audio Alarm):

```
40 X = 2
50 ON X GO TO 700, 800
700 END
800 PRINT HEX(07); "CHANGE PAPER":STOP
RUN
```

Output:

(one-second tone)

CHANGE PAPER

Carriage Return: HEX(0D)

The Carriage Return code prints the current contents of the line buffer and advances the paper one line.

Example (Carriage Return):

```
10 PRINT "INTERNATIONAL SALES"
20 PRINT HEX(0D0D0D)
30 PRINT "LONDON", "ZURICH", "BELGRADE"
RUN
```

Output:

INTERNATIONAL SALES

LONDON

ZURICH

BELGRADE

NOTE

If the automatic line feed has been suppressed (refer to Section 4.2), the paper will not be advanced one line following the carriage return.

Delete: HEX(7F)

The Delete code clears all characters from the print buffer.

Example (Delete):

```
10 PRINT "THIS IS THE FIRST LINE!";
20 PRINT HEX(7F);
30 PRINT "THIS IS THE SECOND LINE!"
RUN
```

Output:

THIS IS THE SECOND LINE!

Diagnostics: HEX(02010201000F)

The Diagnostics code triggers a built-in, 5-line diagnostic test to aid in print intensity adjustments and form alignment. These five lines may also be generated by deselecting the printer, pressing and holding down the FORMS OVERRIDE switch, and pressing the LINE FEED switch. Refer to Section 1.4 for a description of these diagnostics.

Power-On Reset: HEX(020DOC030F)

This control code prints the current contents of the line buffer, executes a form feed, moves the print head to the power-on position at the left end of the carriage, and restores all printer defaults (such as top-of-form, pitch, and line feed).

Select Character Font: HEX(0202aa0F)

The standard Model 2235 contains two fonts: a 10-pitch font and a 12.2-pitch font. When the printer is powered on, or when a Power-On Reset sequence [HEX(020DOC030F)] is executed, the font selected is Font 1 (10-pitch). Either font may be selected by using the following code sequence:

HEX(0202aa0F)

where: aa = 00 for Font 1
 02 for Font 2

When changing from Font 1 to Font 2, the user should also reselect the pitch. Refer to the Select Pitch subsection.

Example (Select Character Font):

```
10 REM SELECT FONT 1: PRINT HEX(0202000F); "FUEL CONSUMPTION"  
20 REM SELECT FONT 2: PRINT HEX(0202020F)  
30 REM SELECT 12.2-PITCH: PRINT HEX(020901020C000F); "WILL REMAIN A  
BIG TARGET OF ENGINE DEVELOPMENT"  
RUN
```

Output:

```
FUEL CONSUMPTION  
WILL REMAIN A BIG TARGET OF ENGINE DEVELOPMENT
```

Select Pitch: HEX(02090102aabb0F)

The standard Model 2235 contains a 10-pitch font and a 12.2-pitch font. When the printer is powered on or when a Power-On Reset sequence is executed, Font 1 (10-pitch) is automatically selected. If the user then selects Font 2 (12.2-pitch), the output appears, not as 12.2-pitch, but as a pseudo-10-pitch that prints 10 characters per inch using the 12.2-pitch font. Pitch selection inside Font 2 is controlled by the Select Pitch sequence. This sequence has the following format.

HEX(02090102aabb0F)

where: aabb = 0A00 for 10-pitch
 0C00 for 12.2-pitch

The user can select 12.2-pitch by executing the Select Font sequence HEX(0202020F) to select Font 2 and the Select Pitch sequence HEX(020901020C000F) to select 12.2 pitch within Font 2. The resulting output will consist of characters from the 12.2-pitch font printed 12.2 characters per inch. To select 10-pitch output after Font 2 has been selected, execute the Select Pitch sequence HEX(020901020A00). The resulting output will consist of characters from the 12.2-pitch font printed 10 characters per inch.

Example (Font 1 and Pitch Selection Within Font 2):

```
10 DIM A$35
20 A$ = "ONE GREAT CHANGE IN THE CITY'S ROLE"
30 REM SELECT FONT 1 (10-PITCH): PRINT HEX(0202000F)
40 PRINT A$
50 REM SELECT FONT 2 (DEFAULTS TO PSEUDO 10-PITCH): PRINT
  HEX(0202020F)
60 PRINT A$
70 REM SELECT 12.2-PITCH: PRINT HEX(020901020C000F)
80 PRINT A$
90 REM SELECT 10-PITCH: PRINT HEX(020901020A000F)
100 PRINT A$
```

Output:

```
ONE GREAT CHANGE IN THE CITY'S ROLE
ONE GREAT CHANGE IN THE CITY'S ROLE
ONE GREAT CHANGE IN THE CITY'S ROLE
ONE GREAT CHANGE IN THE CITY'S ROLE
```

Top-of-Form: HEX(0C)

This code advances the paper to the next top-of-form position. The position is determined by a tab in the first line of Channel 1 of the DAVFU.

CHAPTER 5 DIRECT ACCESS VERTICAL FORMAT UNIT (DAVFU)

5.1 INTRODUCTION

Vertical formatting determines the number of lines to be printed and the amount of blank space to be left between lines on a page of output. Most applications require a form that is 11 inches long, with output single-spaced or double-spaced. A program, stored in the printer, determines the type of vertical formatting to be used through its defaults or from information supplied by the user. Vertical formatting for the Model 2235 is controlled by the 12-channel Direct Access Vertical Format Unit (DAVFU). This method is described in the following sections.

When the printer is powered on or when a Power-On Reset sequence [HEX(020DOC030F)] is executed, the DAVFU defaults to 6 lines per inch and 66 lines per page. The user can control line feed size by using the Set Line Feed Size command sequence described in Section 4.2. When changing line feed size, the user must load an appropriate VFU format before attempting to print. Line feed size cannot be changed within a page. The user should first execute a Top-of-Form command before loading the proper VFU format and setting the corresponding line feed size.

Vertical formatting may be accomplished in three ways. For most applications, use of Hex codes for tabulation to VFU default tab stops will suffice. For more complicated applications, such as forms that necessitate frequently changing vertical format, the user may choose between writing a DAVFU program or using the Vertical Format Control utility (@2273VFU) on the system platter. Because writing a DAVFU load operation is a somewhat complicated process, the utility is recommended. The Vertical Format Control utility can establish most formats that can be written, and may be accessed and used according to the procedures described in Section 5.2. The procedures for writing a DAVFU formatting program are discussed in Section 5.3.

5.2 VERTICAL FORMAT CONTROL UTILITY (@2273VFU)

Accessing the Utilities Menu

Utilities can be accessed through a Utility menu which is available through the system platter. The following two commands will display this menu.

```
SELECT DISK xxx
```

where: xxx = the disk device address of the system utilities

```
LOAD RUN
```

Utilities requiring operator-entered information will display a series of prompts requesting this information. In all cases, type in the necessary response and press the RETURN key; the utility will then request additional information or perform the required procedure.

Vertical Format Control Utility

The Vertical Format Control utility (@2273VFU) allows the user to define and edit the vertical format of the Model 2235 Line Printer DAVFU without the difficulty of programming long code sequences. The user can create, edit, test, and save format data on disk for loading into the DAVFU. Each time the utility is used, the user indicates whether to load a previously created format file or create a new one.

In creating a new vertical format, the user responds to operator prompts and specifies the number of lines per page, the number of lines per inch, and the location of the bottom-of-form. Once the operator supplies this information, an N x 12 grid appears on the CRT screen, where N is the specified number of lines and 12 is the number of channels of the DAVFU. The operator can edit the format by entering tabs indicating top-of-form in Channel 1 of Line 1 and bottom-of-form in Channels 1 and 2 after the last line to be printed. Also, the user can set tabs in the channels of other lines to indicate vertical stops.

Loading a Utility-Defined Vertical Format

Programmers can load a vertical format created by the Vertical Format Control utility by executing the following sequence of statements in the program.

```
DIM T$(128)2  
DATA LOAD DC OPEN T "Filename"
```

where: Filename = name of user file

```
DATA LOAD DC T$(  
$GIO/xyy, (A000,G$) T$(
```

where: xyy = printer address

5.3 FORMATTING USING THE DAVFU

The Direct Access Vertical Format Unit consists of a format memory and associated control codes. The DAVFU is particularly useful for the printing of special forms or printing reports requiring more than one vertical format. Formatting information is supplied by a user-written program and loaded into the DAVFU before printing. This program overrides previous formatting information resident in the Vertical Format Unit.

Load DAVFU: HEX(021Dddd ... 1EOF)

If the Vertical Format Control utility is not used to load the DAVFU, it is necessary to write a program defining the vertical format control sequence. The DAVFU has 12 channels and a maximum length of 144 lines. In the formatting sequence, each print line on the form should be represented by 2 bytes (16 bits), with particular bits used to indicate every channel having a tab stop for that particular line. A byte is represented by a 2-digit Hex code. Therefore, each line of the form should be represented by a 4-digit Hex code. A table of the Hex codes that represent bit patterns may be found in Appendix C. The bit representation for each channel of the DAVFU may be found in Table 5-1. The variable Cn is used, where C = channel and n = number.

The following Hex sequence format should be used for all DAVFU loading operations.

HEX(021Dddd ... 1EOF)

where: dd = standard DAVFU byte pairs

Every sequence must begin with HEX(021D), the Hex code for DAVFU load. This code should be followed with the top-of-form code, 4140, placing a 1 bit in the Channel 1 of the first line. No other tab stops should appear in either byte of the first line. Channel 1 should be used exclusively to mark top-of-form and bottom-of-form.

In a DAVFU formatting program, the Bit 40 should be on for both bytes of each format line code. (If this is not done, the diagnostics error sequence "VFU Bit 6 Not Set" will be illuminated.) For example, a line with the Hex sequence 4040 has no tabs in any channel. As another example, the Hex sequence 4264 has Bit 40 on and a tab stop in Channel 2 (02) of the first byte. The second byte is composed of Bit 40 plus a tab stop in Channel 12 (40 + 20 = 60) and Channel 9 (04) in the second byte.

Table 5-1. DAVFU Data Loading Format

	1st Half of Byte 1				2nd Half of Byte 1				1st Half of Byte 2				2nd Half of Byte 2			
BIT POSITION	7	6	5	4	3	2	1	0	7	6	5	4	3	2	1	0
	80	40	20	10	08	04	02	01	80	40	20	10	08	04	02	01
CHANNEL NUMBERS	0	1	C6	C5	C4	C3	C2	C1	0	1	C12	C11	C10	C9	C8	C7
START CODE	0	0	0	1	1	1	0	1	(See Byte 1)							
FIRST LINE (Top-of-form required)	0	1	0	0	0	0	0	1	0	1	0	0	0	0	0	0
SECOND LINE	0	1	0	0	0	0	1	0	0	1	0	0	0	0	0	0
. (continue as needed)																
BOTTOM-OF-FORM	0	1	0	0	0	0	1	1	0	1	0	0	0	0	0	0
SKIP LINE (optional)	0	1	0	0	0	0	0	0	0	1	0	0	0	0	0	0
.		.														
.		.														
TOP OF FORM	0	1	0	0	0	0	0	1	0	1	0	0	0	0	0	0
STOP CODE	0	0	0	1	1	1	1	0	(See Byte 1)							

Table 5-2. Sample DAVFU Tabulation Scheme

Line	Channel Numbers											
	1	2	3	4	5	6	7	8	9	10	11	12
1	T (4140)											
2		T (4240)										
3			T (4440)									
4		T							T (4244)			
5	(4040)											
6		T	T (4640)									
7												T (4050)
8		T (4240)										
9			T (4440)									
10		T (4240)										
11									T			T (4054)
12		T	T (4440)									
13	(4040)											
14		T (4240)										
15	T	T (4340)										
16	(4040)											
17	(4040)											
18	(4040)											
19	(4040)											
20	T (4140)											

Top-of-form should be followed by a succession of 2-byte codes, each representing a line until the desired form length is reached. Bottom-of-form is represented by a tab in Channels 1 and 2 of the code representing the desired last line of text. This code is 4340 (40 bit is on, and $01 + 02 = 03$). When the bottom-of-form is reached, the printer automatically skips to the next top-of-form. Since bottom-of-form actually indicates the final printed line, it is necessary to insert several more blank lines (4040) until the last physical line on the form is reached. At this line -- Line 66, for example, another top-of-form code (4140) should be inserted. The Hex code (1E) should then terminate the DAVFU load.

The entire string of codes in the DAVFU load operation must contain an even number of digits; otherwise the printer will enter a DAVFU-memory-not-loaded condition. To prevent this occurrence, break up the formatting sequence with a series of Hex code statements.

Examples

The following is an example of a DAVFU formatting program for the VP, MVP, LVP, and SVP. Each Hex code or 2-byte code has been labeled according to a specific function. Obviously, regular users would not require a form with so few print lines.

Example 1:

```

10 SELECT PRINT 215(0)
20 PRINT HEX(021D4140404042404640404040404043404040404041401E0E);

```

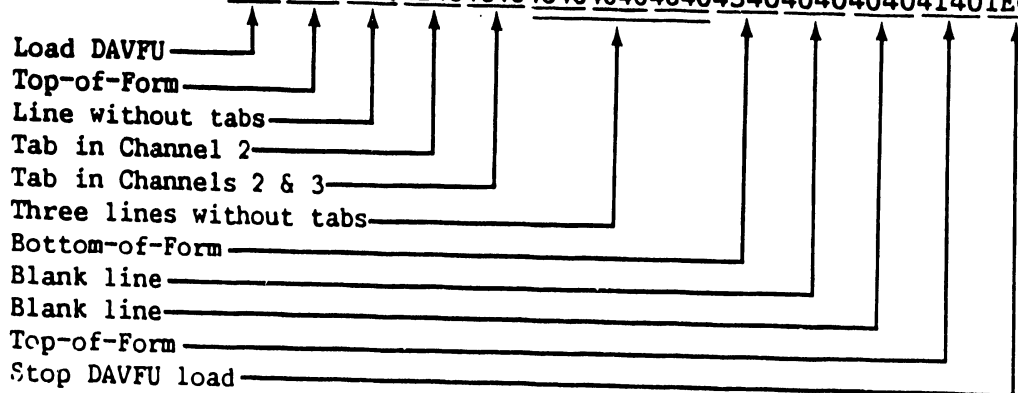

The following sample DAVFU program calls for 15 lines of text printed on a 20-line form, with different tabbing formats set in Channels 2, 3, 9, and 11. Table 5-2 illustrates the tabulation scheme for the 12 channels and 20 lines of the program in Example 2.

Example 2:

```

10 SELECT PRINT 215(0)
20 PRINT HEX(021D41404240444042444040464040504240444042404054464040404
2404340404040404040404041401E);

```

Example 2 will work effectively for those using a 2200VP, MVP, LVP or SVP system, as long as the programmer specifies a line length of 0 in the SELECT statement and follows the stop DAVFU load code sequence with a semicolon. These actions suppress any carriage returns that the system might otherwise generate.

When a formatting program is created for a form with 66 vertical lines, it may become unwieldy, leaving far more room for error. Therefore, users may want to break down their DAVFU formatting programs in the following fashion.

```
10 SELECT PRINT 215(0)
20 PRINT HEX(021D);           :REM START OF DAVFU LOAD
30 PRINT HEX(4140);           :REM TOP-OF-FORM
40 PRINT HEX(4240);           :REM LINE TWO - TAB STOP IN CHANNEL 2
50 PRINT HEX(4440);           :REM LINE THREE - TAB STOP IN CHANNELS 2 & 3
60 PRINT HEX(4244);           :REM LINE FOUR - TAB STOP IN CHANNELS 2 & 9
.
.
.
170 PRINT HEX(4340);          :REM LINE 15 - BOTTOM-OF-FORM
180 PRINT HEX(4040);          :REM LINE 16 - BLANK LINE
.
.
.
210 PRINT HEX(4140);          :REM CLOSING TOP-OF-FORM
220 PRINT HEX(1E);            :REM STOP DAVFU LOAD
```

A less cumbersome means of loading the same program is the BASIC \$GIO command. When using the \$GIO command, a programmer should assume that the DAVFU formatting sequence is an array and dimension it as DIM A\$(128)2. The first byte of A\$() should be HEX(02), the escape code; the second byte of A\$() should be HEX(1D), the DAVFU loading command; the third byte should have the value HEX(4140), the top-of-form code; and so on. The proper command for loading the DAVFU program in this manner is:

```
10 $GIO/215 (A000,G$) A$()
```

Because the programmer can reference a particular channel from within a print routine, the DAVFU formatting program can be used to output data requiring different formats. The various channels of the DAVFU are referenced by using the Vertical Skip control code as described in Section 5.4.

5.4 DAVFU CONTROL CODES

Vertical Skip: HEX(0201021Fxx0F)

The Vertical Skip command allows the programmer to skip a specified number of lines on a form or to the next tab stop in a specified DAVFU channel. The Vertical Skip command sequence has the following format.

HEX(0201021Fxx0F)

where: xx = 0a to advance the platen to the next tab stop defined in Channel a (a must be a Hex digit from 1 to C)

xx = 1a to advance the platen a lines (a must be a Hex digit from 0 to F)

Vertical Tab HEX(0B)

This Vertical Tab code advances the paper to the next preset vertical tab location in Channel 2. Channel 2 is defined as the vertical tab channel.

5.5 DAVFU ERRORS

A number of error conditions may arise when attempting to load the DAVFU. Such errors result in a failure to load the DAVFU, causing the printer to go offline and an error code to be displayed by the diagnostic error indicators (refer to Figure 1-4). The following conditions are error conditions.

- . Loading a program with an odd number of data bytes between the HEX codes 1D and 1E.
- . Attempting to create a formatting program over 144 lines in length without specifying the end of the load with a bottom-of-form code or dummy top-of-form code. (In this instance, the "VFU Greater Than 144 Lines" diagnostics error sequence will be illuminated.)
- . Neglecting to follow the DAVFU start code 1D with a top-of-form code (4140) in the next byte.
- . Neglecting to set Bit 40 to 1 in each byte. (In this instance, the "VFU Bit 6 Not Set" diagnostics error sequence will be illuminated.)

APPENDIX A
HEXADECIMAL CODES

HEX CODE	PRINTER CHARACTER	HEX CODE	PRINTER CHARACTER	HEX CODE	PRINTER CHARACTER
HEX (01)	Not Applicable				
HEX (02)	Escape Code	HEX (3B)	;	HEX (60)	,
HEX (03)	Not Applicable	HEX (3C)	<	HEX (61)	a
HEX (07)	Alarm	HEX (3D)	=	HEX (62)	b
HEX (08)	Not Applicable	HEX (3E)	>	HEX (63)	c
HEX (0A)	Line Feed	HEX (3F)	?	HEX (64)	d
HEX (0B)	Vertical Tab	HEX (40)	@	HEX (65)	e
HEX (0C)	Form Feed	HEX (41)	A	HEX (66)	f
HEX (0D)	Carriage Return	HEX (42)	B	HEX (67)	g
HEX (0E)	Enhanced Print	HEX (43)	C	HEX (68)	h
HEX (0F)	Enhanced Print	HEX (44)	D	HEX (69)	i
HEX (20)	Space	HEX (45)	E	HEX (6A)	j
HEX (21)	!	HEX (46)	F	HEX (6B)	k
HEX (22)	"	HEX (47)	G	HEX (6C)	l
HEX (23)	#	HEX (48)	H	HEX (6D)	m
HEX (24)	\$	HEX (49)	I	HEX (6E)	n
HEX (25)	%	HEX (4A)	J	HEX (6F)	o
HEX (26)	&	HEX (4B)	K	HEX (70)	p
HEX (27)	'	HEX (4C)	L	HEX (71)	q
HEX (28)	(HEX (4D)	M	HEX (72)	r
HEX (29))	HEX (4E)	N	HEX (73)	s
HEX (2A)	*	HEX (4F)	O	HEX (74)	t
HEX (2B)	+	HEX (50)	P	HEX (75)	u
HEX (2C)	,	HEX (51)	Q	HEX (76)	v
HEX (2D)	-	HEX (52)	R	HEX (77)	w
HEX (2E)	.	HEX (53)	S	HEX (78)	x
HEX (2F)	/	HEX (54)	T	HEX (79)	y
HEX (30)	0	HEX (55)	U	HEX (7A)	z
HEX (31)	1	HEX (56)	V	HEX (7B)	
HEX (32)	2	HEX (57)	W	HEX (7C)	
HEX (33)	3	HEX (58)	X	HEX (7D)	
HEX (34)	4	HEX (59)	Y	HEX (7E)	~
HEX (35)	5	HEX (5A)	Z	HEX (7F)	delete
HEX (36)	6	HEX (5B)	[
HEX (37)	7	HEX (5C)	\		
HEX (38)	8	HEX (5D)]		
HEX (39)	9	HEX (5E)	↑		
HEX (3A)	:	HEX (5F)	-		

APPENDIX
D
INTERCONNECT
DIAGRAMS

APPENDIX D
Interconnect Diagrams

D-1 Introduction

Refer to the following diagrams for the 115V and 230V interconnect sequence for the 2233/2235 5533/5535 Dot Matrix Printers.

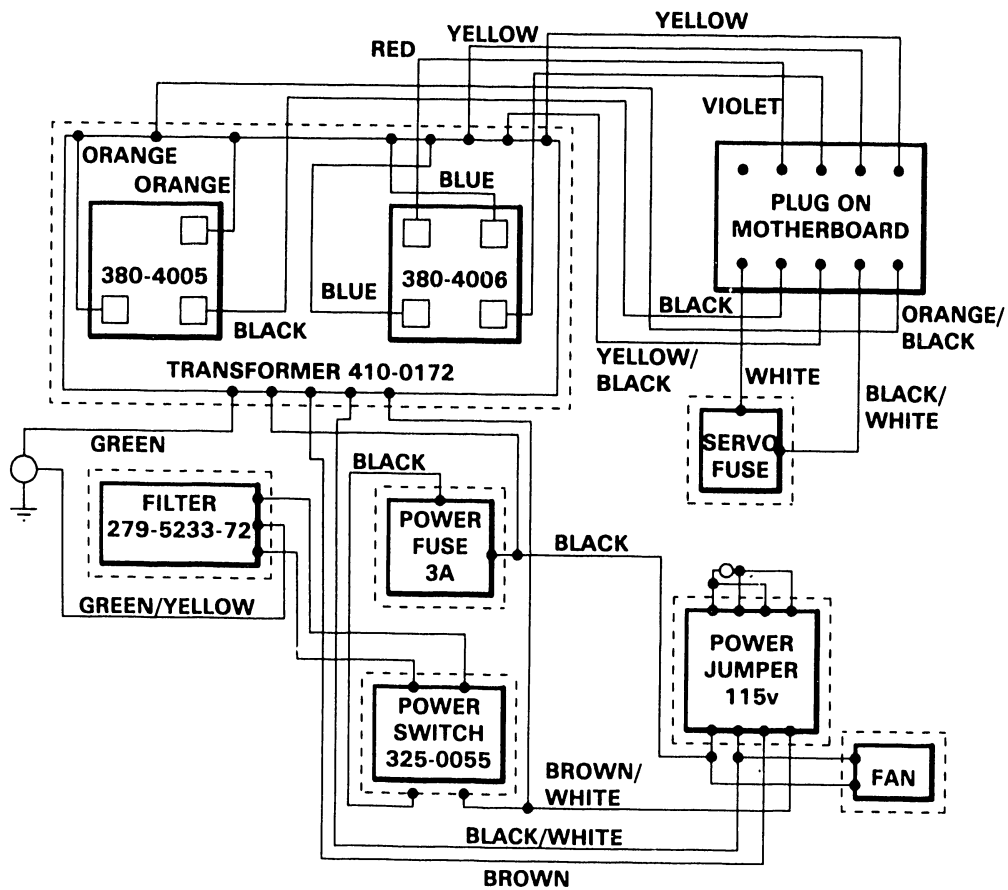

Interconnect Diagram (115V)

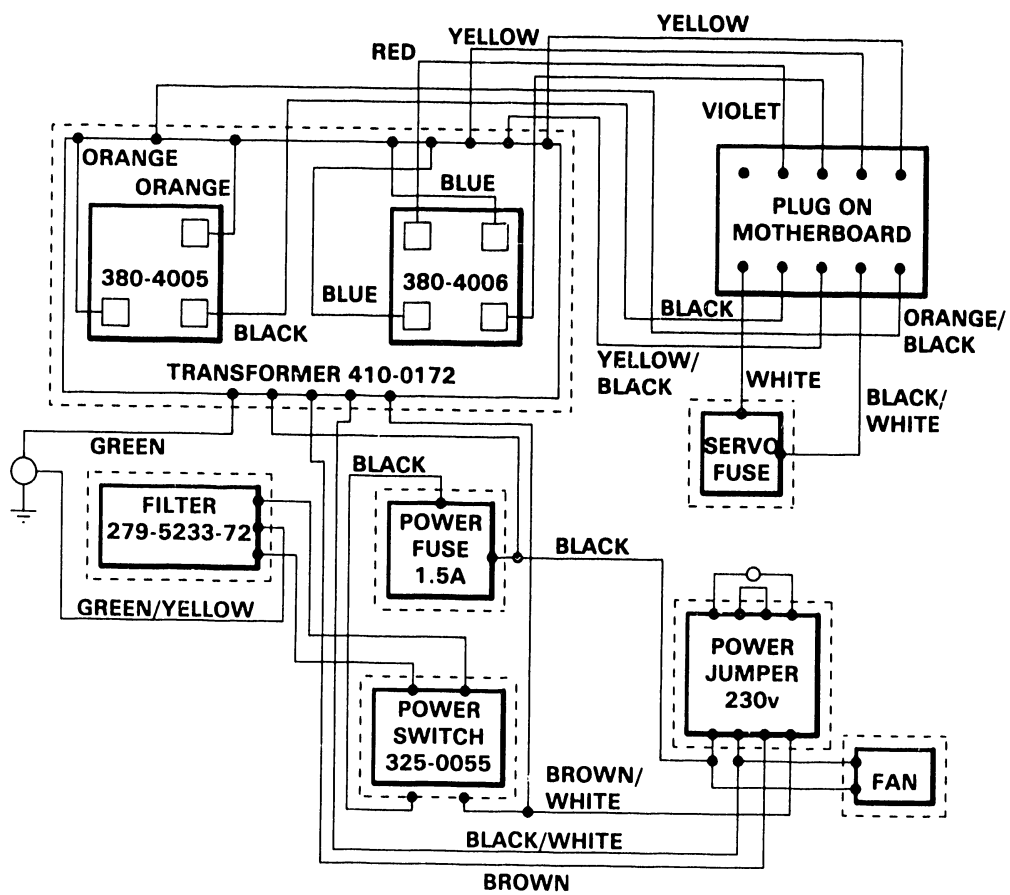

Interconnect Diagram (230V)

CHAPTER

6

SCHE-

MATICS

CHAPTER 6
SCHEMATICS

6.1 INTRODUCTION

Refer to the following Schematic drawings for reference to printer logic circuitry:

Board #	Description	Minimum Rev. level
210-7348	PIO CPU Board	
210-7446	Data Link Board	
210-7547-1A	32K RAM Memory	
210-7593B/-1B	CPU I/O Board	E7
210-7594	Driver/PS REG.	E9
210-7595/-1	Motherboard	
210-7596/-1	Keyboard	
210-7597	Encoder Amp	
210-8393	CPU & I/O	

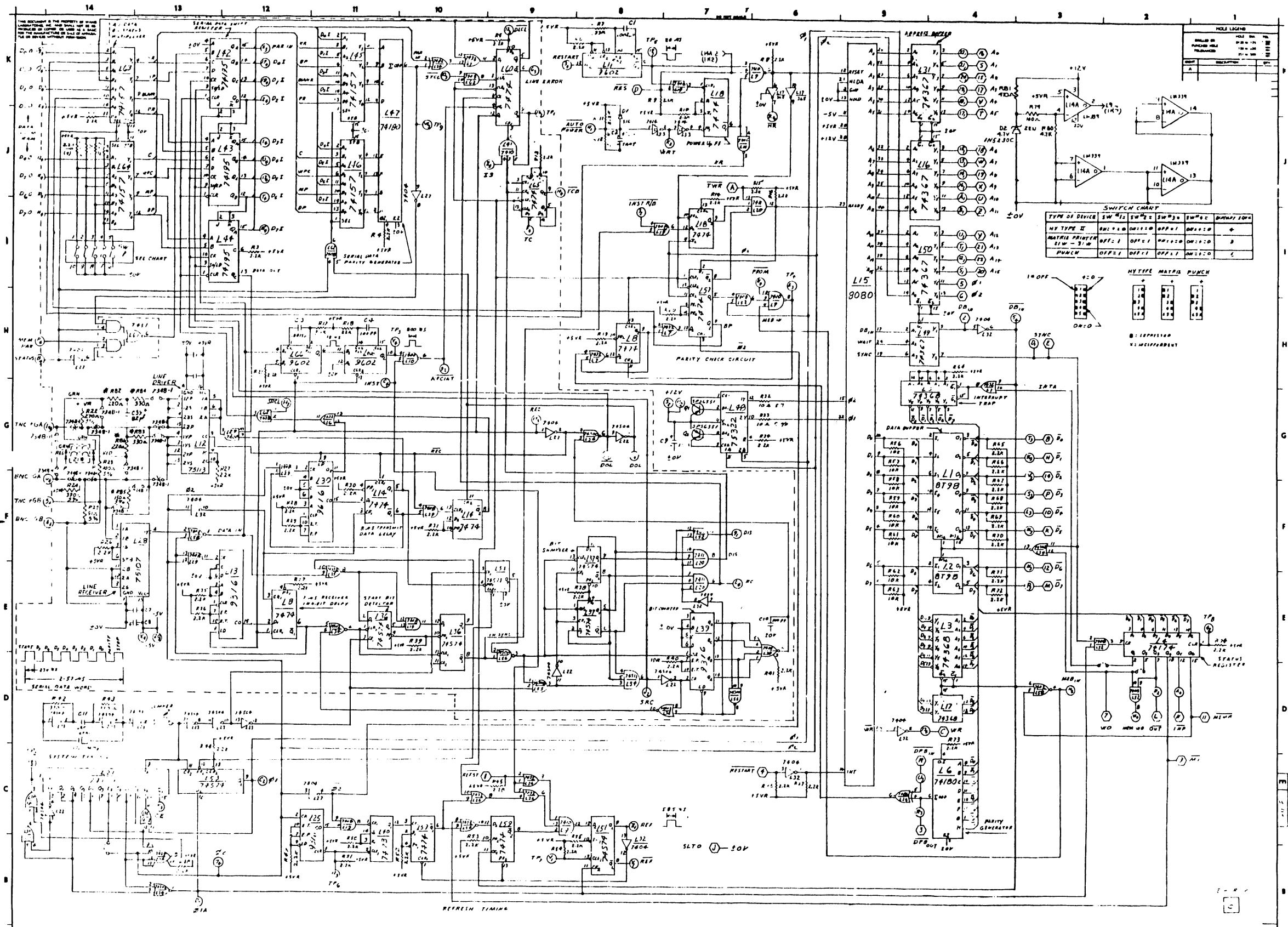

SWITCH CHAINT						
TYPE OF DEVICE	SW #1	SW #2	SW #3	SW #4	SW #5	SW #6
HY TYPE II	OFF: 0	OFF: 1	OFF: 2	OFF: 3	OFF: 4	OFF: 5
MATERIAL PUNCH	OFF: 1	OFF: 1	OFF: 1	OFF: 1	OFF: 1	OFF: 1
PUNCH	OFF: 1	OFF: 1	OFF: 1	OFF: 1	OFF: 1	OFF: 1

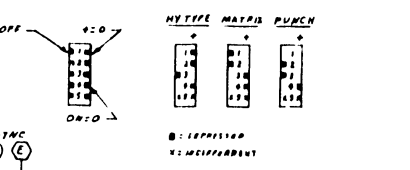

ITEM NO.	QTY	DESCRIPTION
74180	1	PARITY GENERATOR
74181	1	ARITHMETIC LOGIC UNIT
74182	1	PRIORITY ENCODER
74183	1	FULL ADDER
74184	1	COMPARATOR
74185	1	4-BIT BINARY COUNTER
74186	1	4-BIT BINARY DECODER
74187	1	4-BIT BINARY DECODER
74188	1	4-BIT BINARY DECODER
74189	1	4-BIT BINARY DECODER
74190	1	DECADECOUNTER
74191	1	DECADECOUNTER
74192	1	DECADECOUNTER
74193	1	DECADECOUNTER
74194	1	DECADECOUNTER
74195	1	DECADECOUNTER
74196	1	DECADECOUNTER
74197	1	DECADECOUNTER
74198	1	DECADECOUNTER
74199	1	DECADECOUNTER

SEE LOADING VARIATION CHART 74184

WANG PART NO.	QTY	NAME	MATERIAL	DESCRIPTION
74180	1	PARITY GENERATOR	74180	PARITY GENERATOR
74181	1	ARITHMETIC LOGIC UNIT	74181	ARITHMETIC LOGIC UNIT
74182	1	PRIORITY ENCODER	74182	PRIORITY ENCODER
74183	1	FULL ADDER	74183	FULL ADDER
74184	1	COMPARATOR	74184	COMPARATOR
74185	1	4-BIT BINARY COUNTER	74185	4-BIT BINARY COUNTER
74186	1	4-BIT BINARY DECODER	74186	4-BIT BINARY DECODER
74187	1	4-BIT BINARY DECODER	74187	4-BIT BINARY DECODER
74188	1	4-BIT BINARY DECODER	74188	4-BIT BINARY DECODER
74189	1	4-BIT BINARY DECODER	74189	4-BIT BINARY DECODER
74190	1	DECADECOUNTER	74190	DECADECOUNTER
74191	1	DECADECOUNTER	74191	DECADECOUNTER
74192	1	DECADECOUNTER	74192	DECADECOUNTER
74193	1	DECADECOUNTER	74193	DECADECOUNTER
74194	1	DECADECOUNTER	74194	DECADECOUNTER
74195	1	DECADECOUNTER	74195	DECADECOUNTER
74196	1	DECADECOUNTER	74196	DECADECOUNTER
74197	1	DECADECOUNTER	74197	DECADECOUNTER
74198	1	DECADECOUNTER	74198	DECADECOUNTER
74199	1	DECADECOUNTER	74199	DECADECOUNTER

WANG
 MODEL NO. 720
 SERIAL NO. 100000000
 DATE 7/27/77
 BY [Signature]
 APPROVED BY [Signature]
 TITLE [Signature]
 E 7348

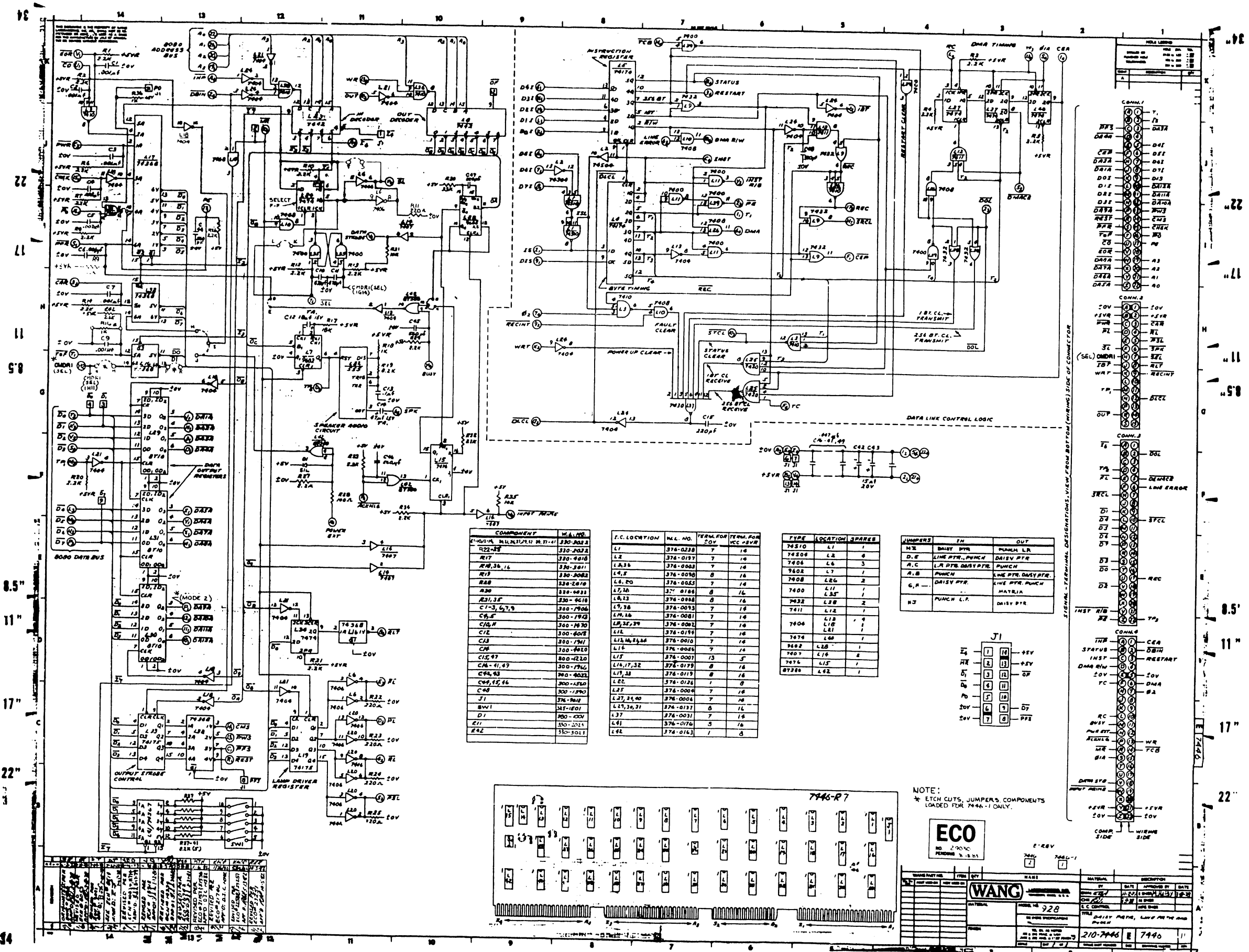

34
22
17
11
5.8
7
0.5"
11"
17"
22"
34

34
22
17
11
5.8
7
0.5"
11"
17"
22"
34

COMPONENT	VAL. AND
R22-25	330-2022
R17	330-2010
R18, 36, 16	330-3011
R19	330-2022
R20	330-2010
R21, 35	330-2022
R23	330-2010
C1-3, 6, 7, 9	300-7906
C4, 5	300-7903
C10, 8	300-7920
C12	300-6026
C13	300-7917
C14	300-7910
C15, 97	300-2210
C16, 41, 43	300-7906
C18, 45	300-4022
C19, 15, 16	300-1510
C20	300-7920
C21	300-1510
C22	330-3011

P.C. LOCATION	REL. NO.	TERM. FOR	TERM. FOR
L1	376-0128	7	10
L2	376-0127	7	10
L3, 3	376-0503	7	10
L4, 2	376-0502	7	10
L5, 20	376-0500	8	16
L6, 20	376-0502	7	10
L7, 20	376-0502	8	16
L8, 20	376-0502	7	10
L9, 20	376-0502	7	10
L10, 20	376-0502	7	10
L11, 20	376-0502	7	10
L12, 20	376-0502	7	10
L13, 20	376-0502	7	10
L14, 20	376-0502	7	10
L15, 20	376-0502	7	10
L16, 17, 32	376-0119	8	16
L19, 28	376-0119	8	16
L22	376-0126	1	8
L23	376-0004	7	10
L27, 25, 40	376-0004	7	10
L27, 26, 31	376-0137	8	16
L37	376-0031	7	10
L41	376-0176	5	16
L42	376-0163	1	8

TYPE	LOCATION	SPARES
7450	L1	1
7450	L2	1
7404	L6	3
7404	L7	1
7408	L6L	2
7400	L11	1
7400	L15	1
7402	L20	2
7411	L12	1
7404	L18	1
7404	L19	1
7404	L21	1
7474	L40	1
7402	L28	1
7407	L16	2
7406	L15	1
8720	L42	1

JUMPERS	IN	OUT
A, B	DAISY PTR.	PUNCH L.R.
D, E	LINE PTR., PUNCH	DAISY PTR.
A, C	L.R. PTR., DAISY PTR.	PUNCH
A, B	PUNCH	LINE PTR., DAISY PTR.
G, R	DAISY PTR.	MATRIX
H, T	PUNCH L.R.	DAISY PTR.

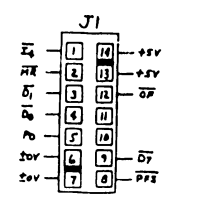

NOTE:
* ETCH CUTS, JUMPERS, COMPONENTS
LOADED FOR 7446-1 ONLY.

ECO

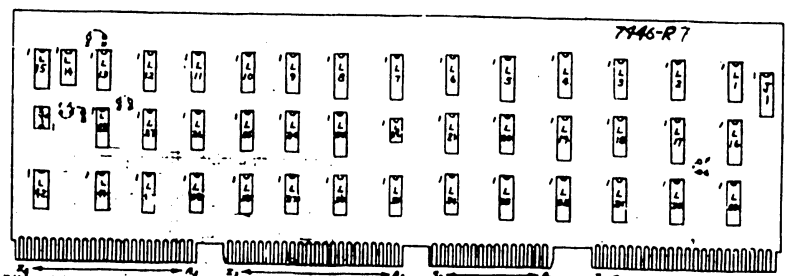

DATE	BY	REVISION
11/17/67	WANG	1
11/17/67	WANG	2
11/17/67	WANG	3
11/17/67	WANG	4
11/17/67	WANG	5
11/17/67	WANG	6
11/17/67	WANG	7
11/17/67	WANG	8
11/17/67	WANG	9
11/17/67	WANG	10
11/17/67	WANG	11
11/17/67	WANG	12
11/17/67	WANG	13
11/17/67	WANG	14
11/17/67	WANG	15
11/17/67	WANG	16
11/17/67	WANG	17
11/17/67	WANG	18
11/17/67	WANG	19
11/17/67	WANG	20
11/17/67	WANG	21
11/17/67	WANG	22
11/17/67	WANG	23
11/17/67	WANG	24
11/17/67	WANG	25
11/17/67	WANG	26
11/17/67	WANG	27
11/17/67	WANG	28
11/17/67	WANG	29
11/17/67	WANG	30

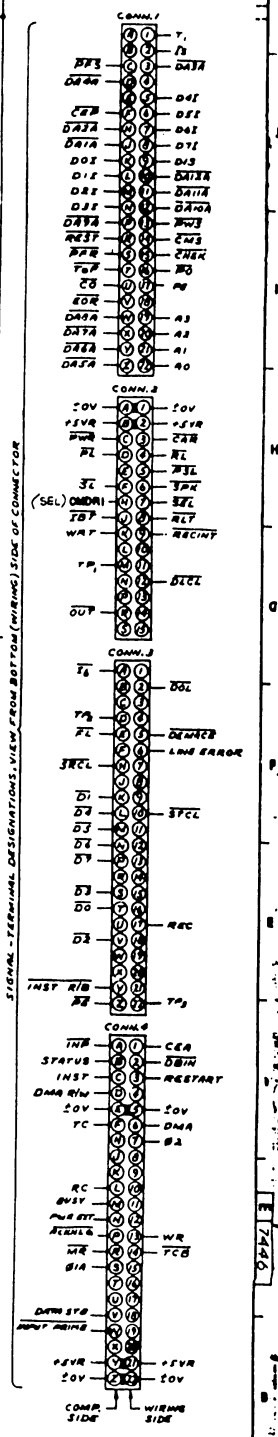

SIGNAL - TERMINAL DESIGNATIONS, VIEW FROM BOTTOM (WRING) SIDE OF CONNECTOR

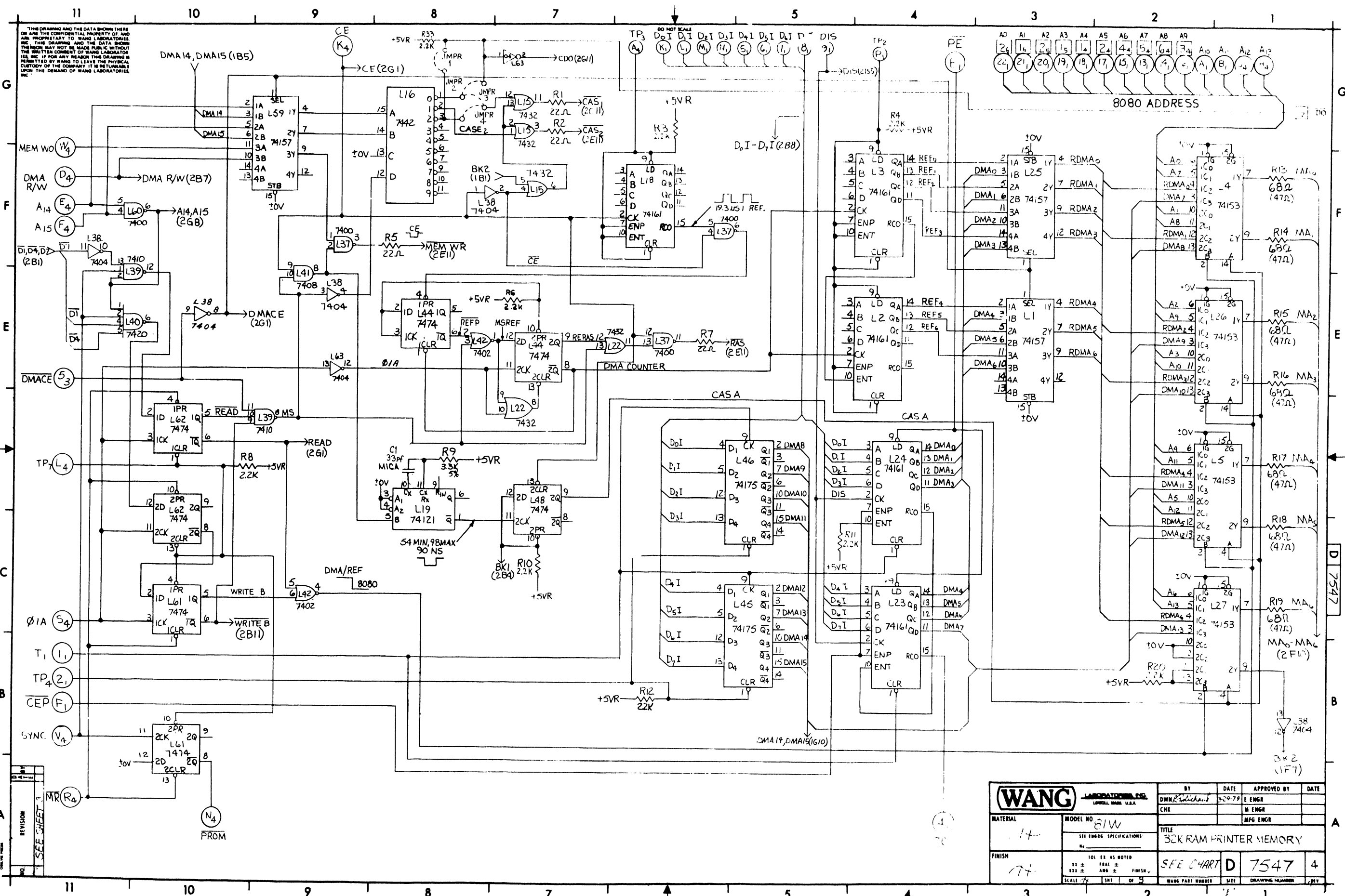

THIS DRAWING AND THE DATA SHOWN THERE ON ARE THE CONFIDENTIAL PROPERTY OF AND ARE PROPRIETARY TO WANG LABORATORIES, INC. THIS DRAWING AND THE DATA SHOWN THEREON MAY NOT BE MADE PUBLIC WITHOUT THE WRITTEN CONSENT OF WANG LABORATORIES, INC. IF FOR ANY REASON THIS DRAWING IS REPRODUCED BY WANG TO LEAVE THE PHYSICAL CUSTODY OF THE COMPANY IT IS RETURNABLE UPON THE DEMAND OF WANG LABORATORIES, INC.

REV	DESCRIPTION
1	SEE SHEET 3

WANG LABORATORIES, INC. LITTLE ROCK, ARK. U.S.A.		BY DWR/Redwood	DATE 3-29-79	APPROVED BY E ENGR	DATE
MATERIAL 14		CHK		M ENGR	
MODEL NO 31W		TITLE 32K RAM PRINTER MEMORY		MFG ENGR	
FINISH 77		SEE CHART		D	7547
SCALE 7/8		SHT	OF 5	WANG PART NUMBER	SIZE

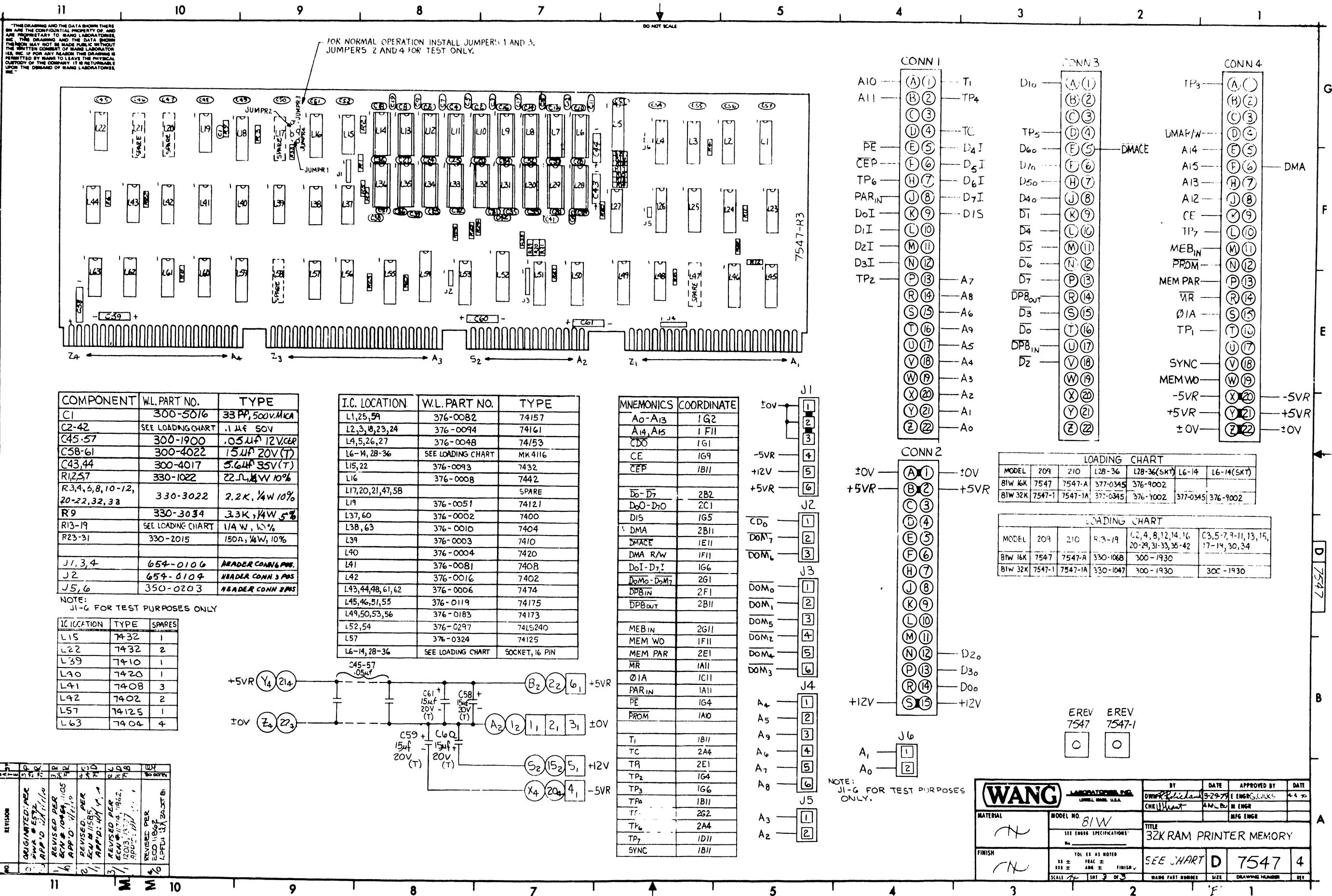

THIS DRAWING AND THE DATA SHOWN THEREIN ARE THE CONFIDENTIAL PROPERTY OF AND ARE PROPRIETARY TO WANG LABORATORIES, INC. THE DRAWING AND THE DATA SHOWN THEREIN MAY NOT BE MADE PUBLIC WITHOUT THE WRITTEN CONSENT OF WANG LABORATORIES, INC. IF FOR ANY REASON THE DRAWING IS FURNISHED BY WANG TO LEAVE THE PHYSICAL CUSTODY OF THE COMPANY IT IS RETURNABLE UPON THE DEMAND OF WANG LABORATORIES, INC.

FOR NORMAL OPERATION INSTALL JUMPER 1 AND 3. JUMPER 2 AND 4 FOR TEST ONLY.

COMPONENT	W.L. PART NO.	TYPE
C1	300-5016	33 PP, 500V, MICA
C2-42	SEE LOADING CHART	.1 μF 50V
C45-57	300-1900	.05 μF 12V, CEP
C58-61	300-4022	15 μF 20V (T)
C43, 44	300-4017	5.6 μF 35V (T)
R1, 2, 57	330-1022	22 Ω, 1/4 W 10%
R3, 4, 6, 8, 10-12, 20-22, 32, 33	330-3022	2.2 K, 1/4 W 10%
R9	330-3034	3.3 K, 1/4 W 5%
R13-19	SEE LOADING CHART	1/4 W, 10%
R23-31	330-2015	150 Ω, 1/4 W, 10%
J1, 3, 4	654-0106	HEADER CONN 6 POS.
J2	654-0104	HEADER CONN 3 POS.
J5, 6	350-0203	HEADER CONN 2 POS.

I.C. LOCATION	W.L. PART NO.	TYPE
L1, 25, 59	376-0082	74157
L2, 3, 18, 23, 24	376-0094	74161
L4, 5, 26, 27	376-0048	74153
L6-14, 28-36	SEE LOADING CHART	MK 4116
L15, 22	376-0093	7432
L16	376-0008	7442
L17, 20, 21, 47, 58		SPARE
L19	376-0051	74121
L37, 60	376-0002	7400
L38, 63	376-0010	7404
L39	376-0003	7410
L40	376-0004	7420
L41	376-0081	7408
L42	376-0016	7402
L43, 44, 48, 61, 62	376-0006	7474
L45, 46, 51, 55	376-0119	74175
L49, 50, 53, 56	376-0183	74173
L52, 54	376-0297	74LS240
L57	376-0324	74125
L6-14, 28-36	SEE LOADING CHART	SOCKET, 16 PIN

MNEMONICS	COORDINATE
A0-A13	1G2
A14, A15	1F11
CD0	1G1
CE	1G9
CEP	1B11
D0-D7	2B2
D00-D10	2C1
DIS	1G5
DMA	2B11
DMA R/W	1F11
DoI-D7I	1G6
DOM0-D7M7	2G1
DPB IN	2F1
DPB OUT	2B11
MEB IN	2G11
MEM WD	1F11
MEM PAR	2E1
MR	1A11
Ø1A	1C11
PAR IN	1A11
PE	1G4
PROM	1A10
T1	1B11
TC	2A4
TP	2E1
TP2	1G4
TP3	1G6
TP4	1B11
TP5	2G2
TP6	2A4
TP7	1D11
SYNC	1B11

MODEL	209	210	L28-36	L28-36(SKT)	L6-14	L6-14(SKT)
BIW 16K	7547	7547-A	377-0345	376-9002		
BIW 32K	7547-1	7547-1A	377-0345	376-9002	377-0345	376-9002

MODEL	209	210	R13-19	62, 4, 8, 12, 14, 16, 20-29, 31-33, 35-42	03, 5-7, 9-11, 13, 15, 17-19, 30, 34
BIW 16K	7547	7547-A	330-1068	300-1930	
BIW 32K	7547-1	7547-1A	330-1047	300-1930	300-1930

I.C. LOCATION	TYPE	SPARES
L15	7432	1
L22	7432	2
L39	7410	1
L40	7420	1
L41	7408	3
L42	7402	2
L57	74125	1
L63	7404	4

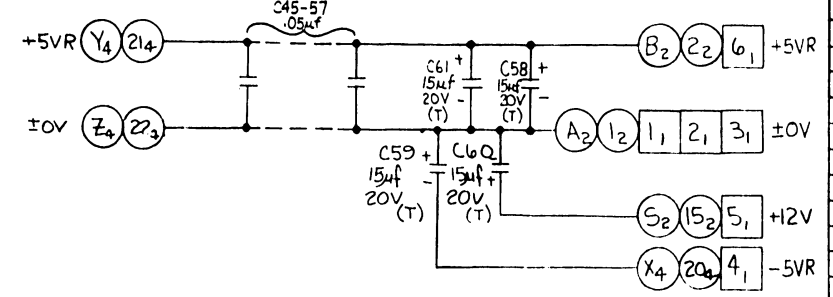

NO.	REVISION	BY	DATE	APPROVED BY	DATE
1	ORIGINAL PER APP'D. 1/10/70				
2	REVISED PER APP'D. 1/10/70				
3	REVISED PER APP'D. 1/10/70				
4	REVISED PER APP'D. 1/10/70				
5	REVISED PER APP'D. 1/10/70				

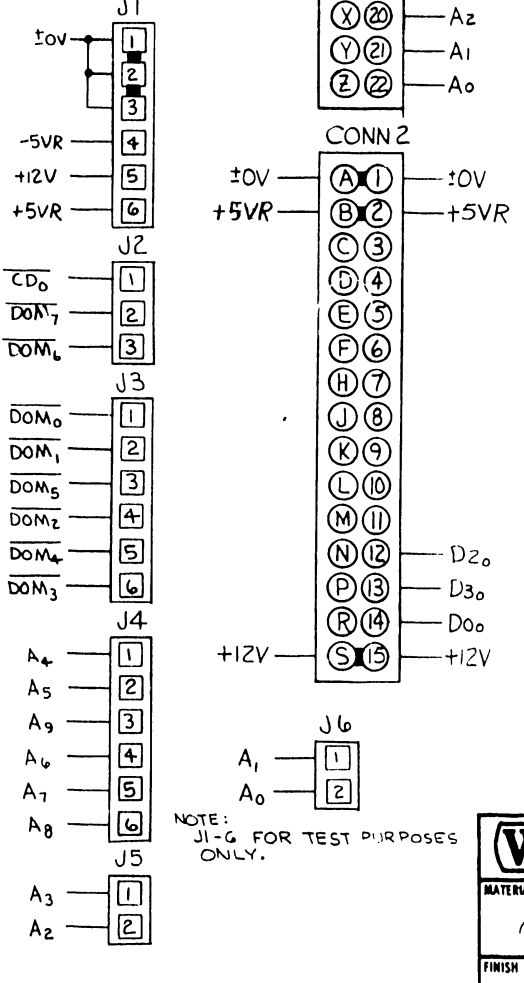

WANG LABORATORIES, INC. U.S. PATENT & TRADEMARK OFFICE		BY	DATE	APPROVED BY	DATE
MATERIAL		DWIGHT R. KELLEY	3-29-77	E. ENGR. G. J. KUKS	4-4-70
MODEL NO. 81W		CHELLI		MEM. ENGR.	
SEE ENGINE SPECIFICATIONS		TITLE			
FINISH		32K RAM PRINTER MEMORY			
TOL. IS AS NOTED		SEE CHART		D	7547
SCALE 1:1		SHEET 3 OF 3		WANG PART NUMBER	SIZE
		DRAWING NUMBER		REV	

THIS DRAWING AND THE DATA SHOWN THERE ON ARE THE CONFIDENTIAL PROPERTY OF WANG LABORATORIES, INC. THIS DRAWING AND THE DATA SHOWN THEREIN MAY NOT BE MADE PUBLIC WITHOUT THE WRITTEN CONSENT OF WANG LABORATORIES, INC. IF FOR ANY REASON THIS DRAWING IS PERMITTED BY WANG TO LEAVE THE PHYSICAL CUSTODY OF THE COMPANY, IT IS RETURNABLE UPON THE DEMAND OF WANG LABORATORIES, INC.

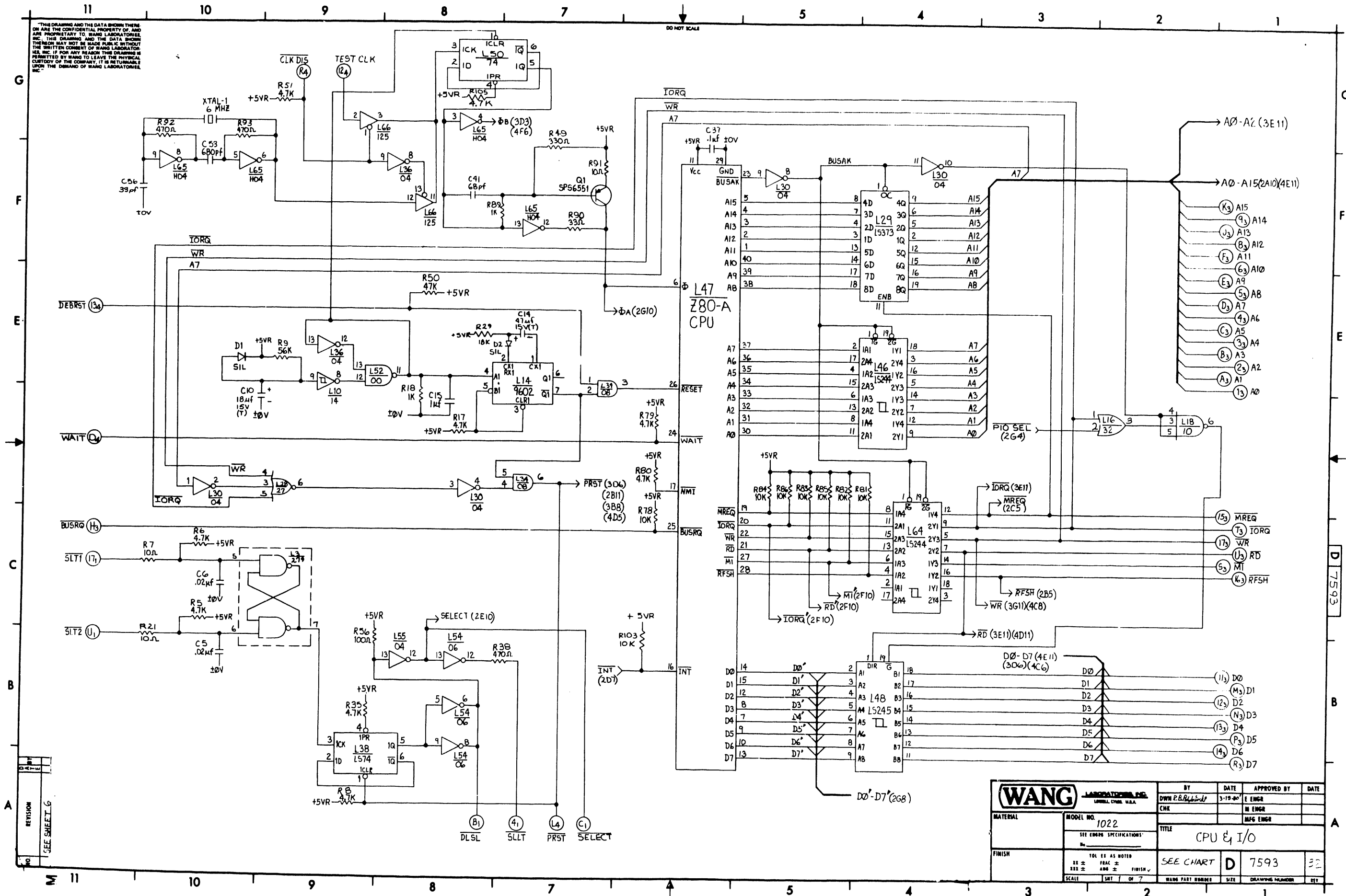

WANG LABORATORIES, INC. LABORATORY, CHINA, U.S.A.		BY DWN R. B. [Signature]	DATE 3-19-80	APPROVED BY E ENGR	DATE
MATERIAL	MODEL NO. 1022	CHK		M ENGR	
SEE ENGR SPECIFICATIONS		TITLE CPU & I/O			
FINISH	TOL ET AS NOTED	SCALE SEE CHART	D	7593	32
	SCALE	SMT / OF 7	WANG PART NUMBER	SIZE	DRAWING NUMBER

REV	DESCRIPTION
1	ISSUED FOR FAB
2	REVISED TO CORRECT ERROR

SEE SHEET G

THIS DRAWING AND THE DATA SHOWN THERE ON ARE THE CONFIDENTIAL PROPERTY OF AND ARE PROPRIETARY TO WANG LABORATORIES, INC. THE DRAWING AND THE DATA SHOWN THEREON MAY NOT BE MADE PUBLIC WITHOUT THE WRITTEN CONSENT OF WANG LABORATORIES, INC. IF FOR ANY REASON THIS DRAWING IS PERMITTED BY WANG TO LEAVE THE PHYSICAL CUSTODY OF THE COMPANY, IT IS RETURNABLE UPON THE DEMAND OF WANG LABORATORIES, INC.

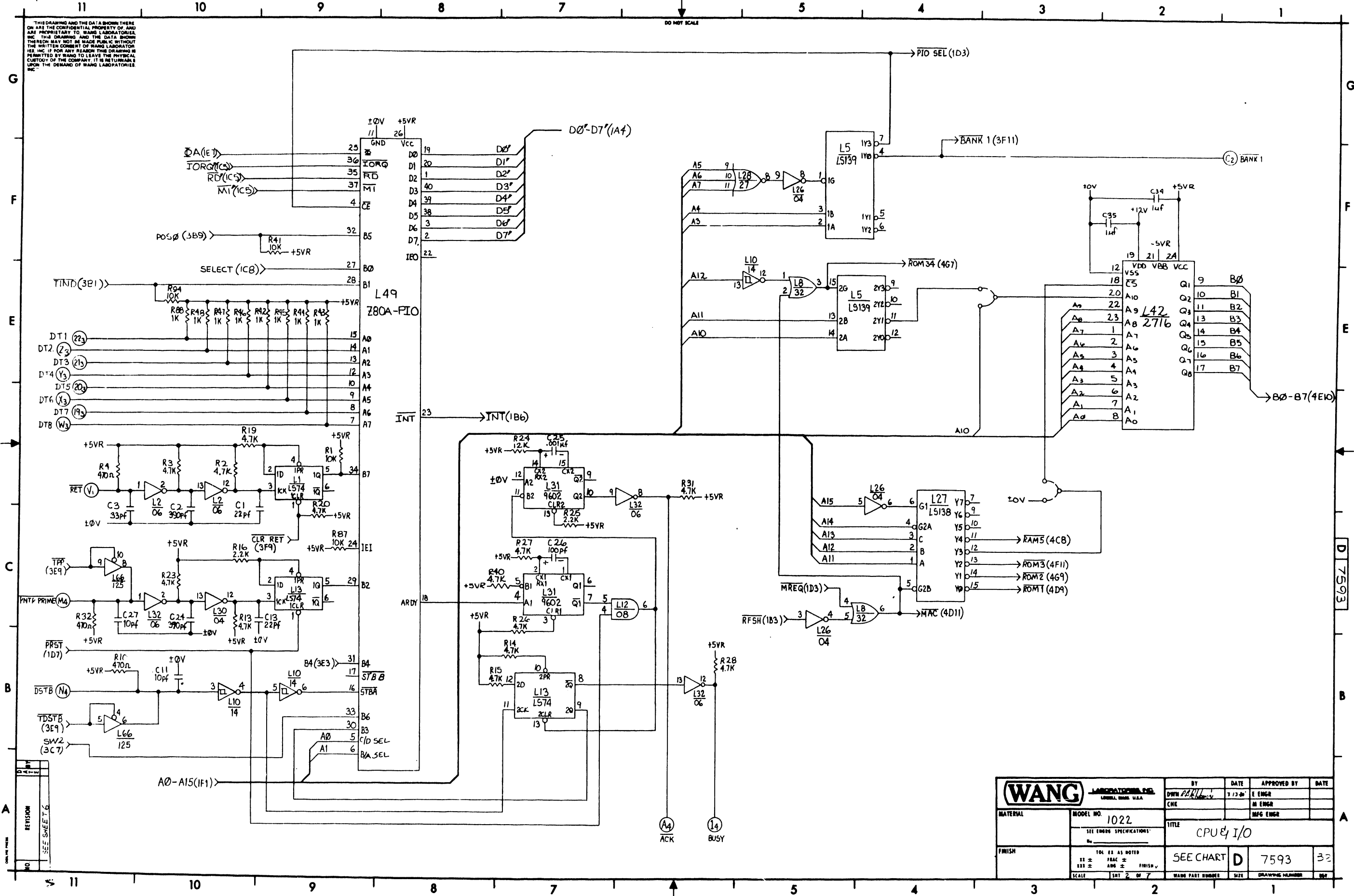

WANG LABORATORIES, INC. LIMEX BLDG. U.S.A.		BY DWN PERKINS	DATE 7/13/73	APPROVED BY E ENGR	DATE
MATERIAL	MODEL NO. 1022	CHE		M ENGR	
SEE ENGR SPECIFICATIONS		TITLE CPU & I/O		MFG ENGR	
FINISH	TOL AS NOTED	SEE CHART	D	7593	32
	SCALE	1/2" = 1"	SHT 2 OF 7	WANG PART NUMBER	DRAWING NUMBER

THIS DRAWING AND THE DATA SHOWN THERE ON ARE THE CONFIDENTIAL PROPERTY OF, AND ARE PROPRIETARY TO, WANG LABORATORIES, INC. THIS DRAWING AND THE DATA SHOWN THEREON MAY NOT BE MADE PUBLIC WITHOUT THE WRITTEN CONSENT OF WANG LABORATORIES, INC. IF FOR ANY REASON THIS DRAWING IS PERMITTED BY WANG TO LEAVE THE PHYSICAL CUSTODY OF THE COMPANY, IT IS RETURNABLE UPON THE DEMAND OF WANG LABORATORIES, INC.

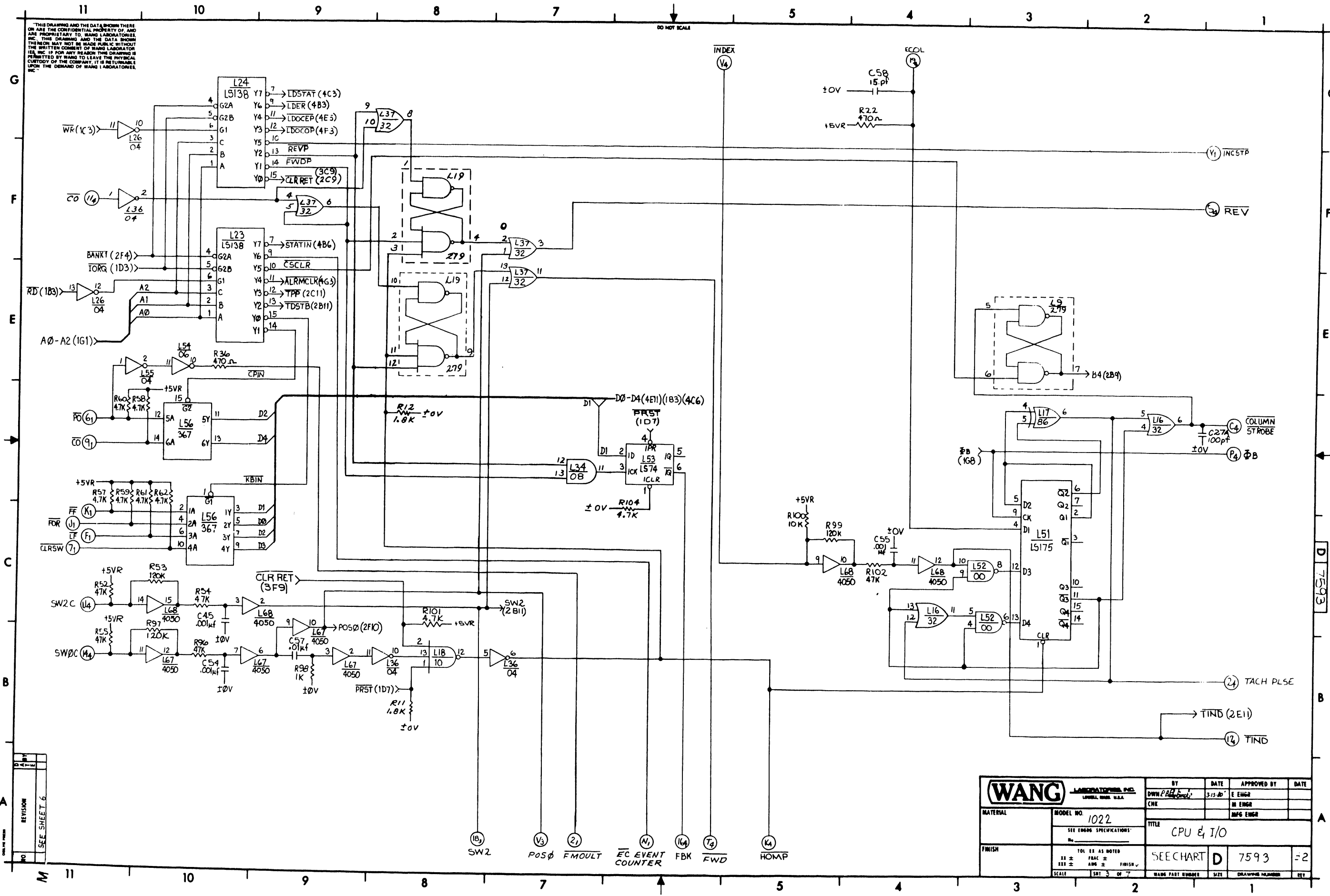

REV	DATE	BY	APP'D

WANG LABORATORIES, INC. LOWELL, MASS. U.S.A.		BY DWN PAB	DATE 3-13-67	APPROVED BY E ENGR	DATE
MATERIAL	MODEL NO. 1022	CNR	TITLE CPU & I/O		
FINISH	SEE ENGR SPECIFICATIONS	SCALE 1:1		SIZE D	DRAWING NUMBER 7593
TOL. AS NOTED		SCALE 1:1		SIZE D	DRAWING NUMBER 7593
XX ±		FRAC ±		FINISH	
XXX ±		ANG ±		SCALE	
SCALE SMT 3 OF 7		MADE PART NUMBER		REV 2	

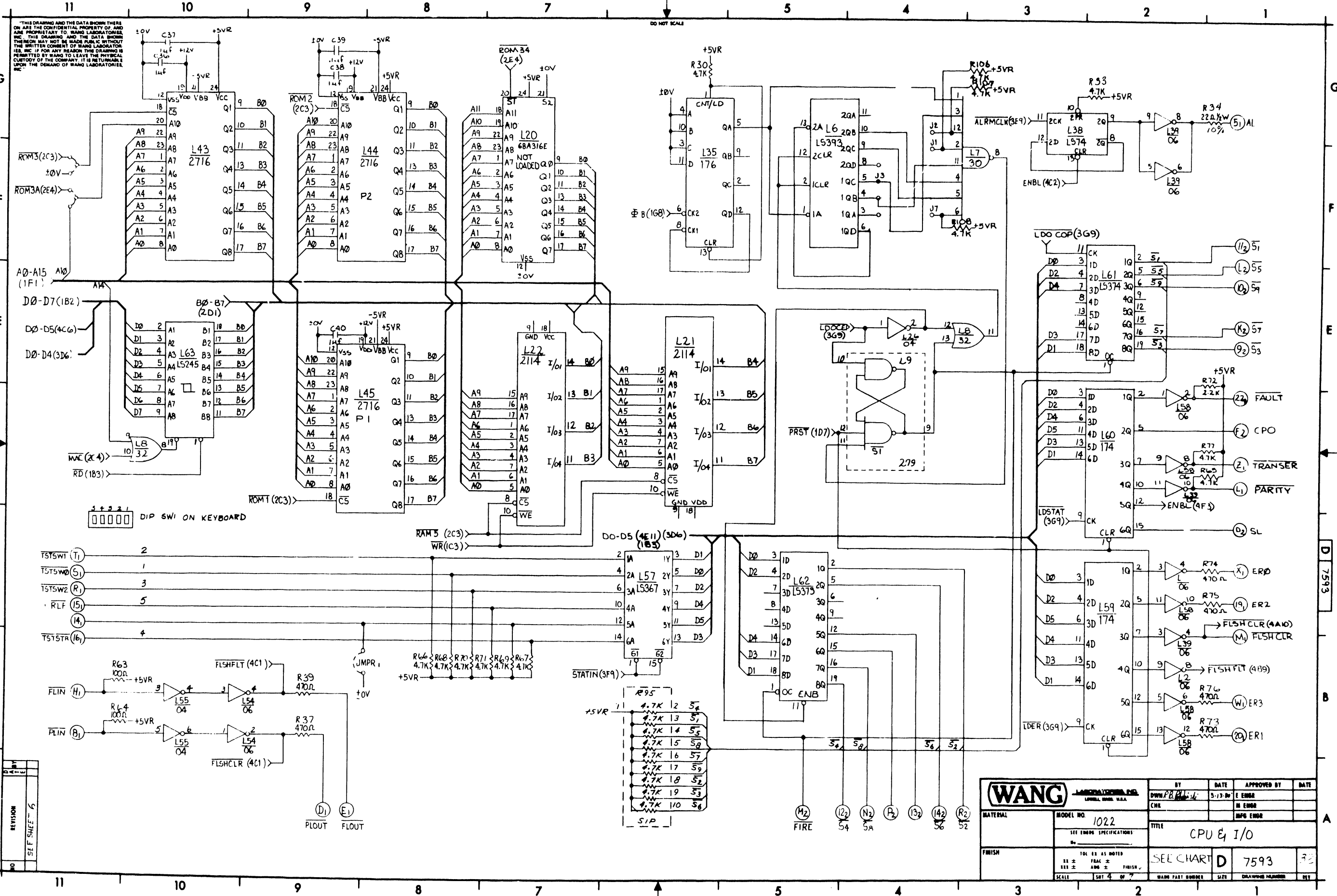

THIS DRAWING AND THE DATA SHOWN THERE ON ARE THE CONFIDENTIAL PROPERTY OF WANG LABORATORIES, INC. THIS DRAWING AND THE DATA SHOWN THEREIN MAY NOT BE MADE PUBLIC WITHOUT THE WRITTEN CONSENT OF WANG LABORATORIES, INC. IF FOR ANY REASON THIS DRAWING IS PERMITTED BY WANG TO LEAVE THE PHYSICAL CUSTODY OF THE COMPANY, IT IS RETURNABLE UPON THE DEMAND OF WANG LABORATORIES, INC.

REV	DATE	BY	DESCRIPTION
1			
2			
3			
4			
5			
6			

WANG		DATE	APPROVED BY	DATE
MODEL NO. 1022		DATE	E ENGR	
TITLE			M ENGR	
CPU & I/O			DPS ENGR	
FINISH		SCALE	SIZE	DRAWING NUMBER
SEE CHART		SET 4 OF 7	D	7593

THIS DRAWING AND THE DATA SHOWN THERE ON ARE THE CONFIDENTIAL PROPERTY OF, AND ARE PROPRIETARY TO, WANG LABORATORIES, INC. THIS DRAWING AND THE DATA SHOWN THEREON MAY NOT BE MADE PUBLIC WITHOUT THE WRITTEN CONSENT OF WANG LABORATORIES, INC. IF FOR ANY REASON THIS DRAWING IS PERMITTED BY WANG TO LEAVE THE PHYSICAL CUSTODY OF THE COMPANY, IT IS RETURNABLE UPON THE DEMAND OF WANG LABORATORIES, INC.

DO NOT SCALE

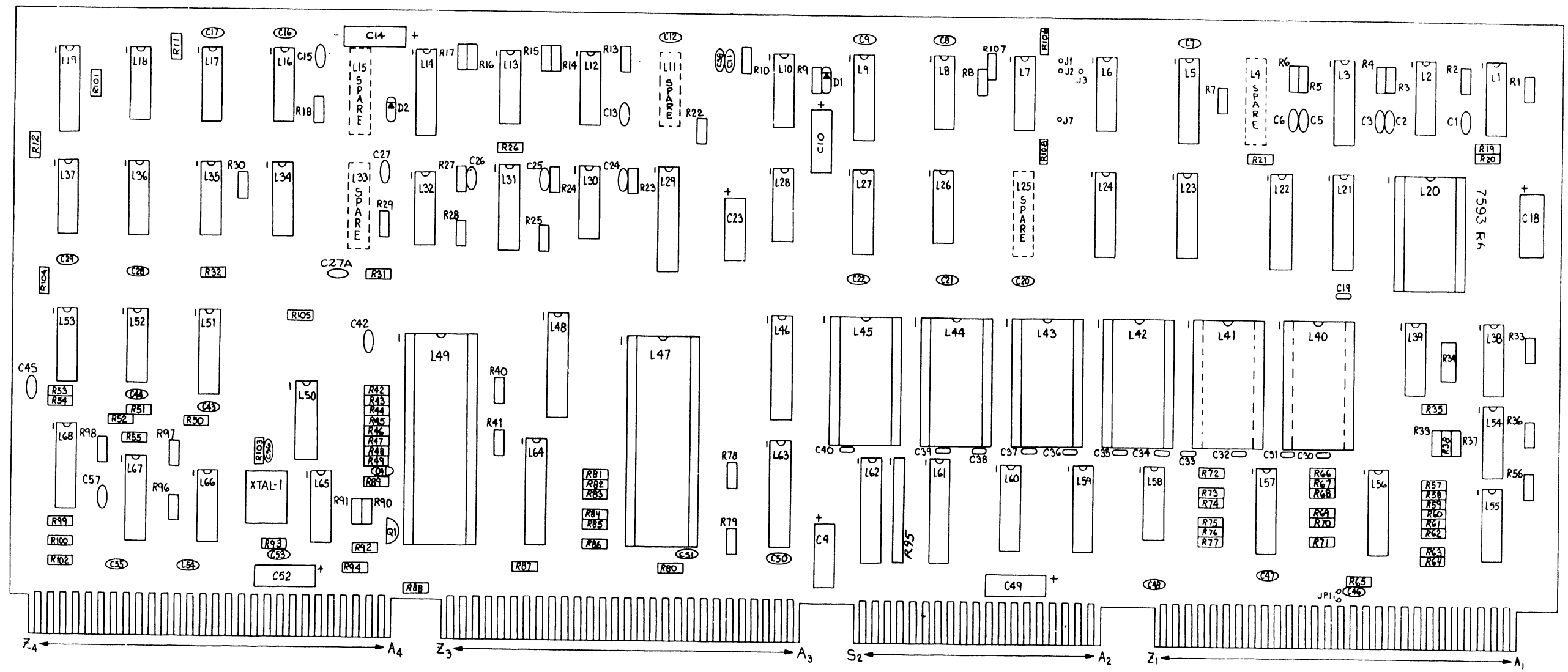

NO.	REVISION

SEE SHEET 10

WANG LABORATORIES, INC. CORPORATE HEADQUARTERS 1000 WASHINGTON STREET CAMBRIDGE, MASSACHUSETTS 02142		BY DWN F. BULLOCK	DATE 4-14-80	APPROVED BY E ENGR	DATE
MATERIAL	MODEL NO. 1022	TITLE CPU & I/O			
FINISH	TOL. EX. AS NOTED DIM. ± .005 FINISH ± .005	SCALE 1:1	SIZE D	DRAWING NUMBER 7593	SHEET 5 OF 7

THIS DRAWING AND THE DATA SHOWN THERE ON ARE THE CONFIDENTIAL PROPERTY OF WANG LABORATORIES, INC. THIS DRAWING AND THE DATA SHOWN THEREON MAY NOT BE MADE PUBLIC WITHOUT THE WRITTEN CONSENT OF WANG LABORATORIES, INC. IF FOR ANY REASON THIS DRAWING IS PERMITTED BY WANG TO LEAVE THE PHYSICAL CUSTODY OF THE COMPANY IT IS RETURNABLE UPON THE DEMAND OF WANG LABORATORIES, INC.

DO NOT SCALE

COMPONENT	TYPE	W.L. PART NO.
R1, 41, 78, R1-87 5, 11, 103	10K, 1/4W, 5%	330-4011
R2, 3, 5, 6, 8, 13, 15, 17, 19, 20, 23, 26-28, 30, 31, 33, 35, 40, 50, 51, 57-62, 65-71, 77, 79, 80, 101, 101-108	4.7K, 1/4W, 5%	330-3048
R4, 10, 36-39, 73-76, 92, 93, 22, 32	470Ω, 1/4W, 5%	330-2048
R7, 21, 31	10Ω, 1/4W, 5%	330-1011
R9	56K, 1/4W, 5%	330-4057
R11, 12	1.8K, 1/4W, 5%	330-3019
R16, 25, 72	2.2K, 1/4W, 5%	330-3023
R18, 42, 48, 88, 81, 98	1K, 1/4W, 5%	330-3011
R24	12K, 1/4W, 5%	330-4013
R29	18K, 1/4W, 5%	330-4019
R34	22Ω, 1/4W, 10%	331-1022
R49	330Ω, 1/4W, 5%	330-2084
R52, 54, 55, 96, 102	47K, 1/4W, 5%	330-4043
R53, 97, 99	120K, 1/4W, 5%	330-5013
R56, 63, 64	100Ω, 1/4W, 5%	330-2011
R90	33Ω, 1/4W, 5%	330-1034
R	10K 1/4W ±%	330-4011
R95	4.7K SIP	333-0812
C2, 24	390pf 500V	300-1390
C3, 50	33pf 500V, 10%	300-1033
C5, 6	.02μf, 25V, 80%	300-1904
C7, 9, 12, 16, 17, 20-22, 28, 29, 42-44, 46-48, 50	.047μf 50V, 10%	300-1966
C1, 13	2.2pF	300-1022
C10	18μf, 15V, 20%(T)	300-4018
C11, 27	10μf, 500V, 10%	300-1010
C14	47μf, 15V, 10%(T)	300-4020
C15	1μf, 50V, 20%	300-1943
C18, 23, 49, 52, 4	15μf, 20V, 10%(T)	300-4022
C19, 30, 32, 34-38, 40	1μf (MICRO)	300-1931
C25, 45, 54, 55	.001μf 1000V, 0%	300-1821
C26, 27A	100pf, 100V, 20%	300-1100
C31, 33, 39, 51	1μf 50V (HF)	300-1930
C41	68pf, 500V, 10%	300-1068
C53	680pf 500V 10%	300-1680
C57	.01μf 25V CER	300-1903
C58	15pf 500V 10%	300-1015
D1, 2	SIL	380-1001
Q1	9P56551	375-1050
ATAL-1	6 MHZ	321-0013
L20, 40-45	24 PIN SOCKET	376-9003
L47, 49	40-PIN SOCKET	376-9011
L21, 22	18 PIN SOCKET	376-9014

LOCATION	TYPE	W.L. PART NO.
L1, 13, 38, 53	74LS74	376-0155
L2, 32, 39, 54, 58	7406	376-0055
L3, 9, 19	74279	376-0188
L5	74LS139	376-0226
L6	74LS393	376-0307
L7	7430	376-0031
L8, 16, 37	7432	376-0093
L10	7414	376-0139
L12, 34	7408	376-0081
L14, 31	9602	376-0104
L17	7486	376-0036
L18	7410	376-0003
L20	NOT LOADED	
L21, 22	2114	377-0341-L
L23, 24, 27	74LS138	376-0294
L26, 30, 36, 55	7404	376-0010
L28	7427	376-0125
L29, 62	74LS373	376-0310
L35	74176	376-0167
L42-45	TMS-2716	SEE CHART
L46, 64	74LS244	376-0288
L47	Z80A-CPU	SEE CHART
L48, 63	74LS245	376-0285
L49	Z80A-PIO	SEE CHART
L50	7474	376-0006
L51	74LS175	376-0160
L52	7400	376-0002
L56	74367	376-0176
L57	74LS367	376-0192
L59, 60	74174	376-0098
L61	74LS374	376-0286
L65	74H04	376-0045
L66	74125	376-0324
L67, 68	CD4050	376-0372
L4, 15, 11, 25, 33	SPARES	

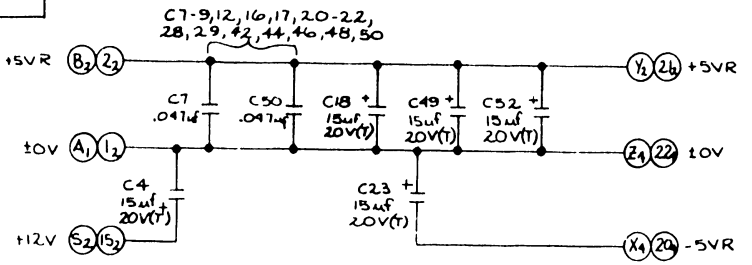
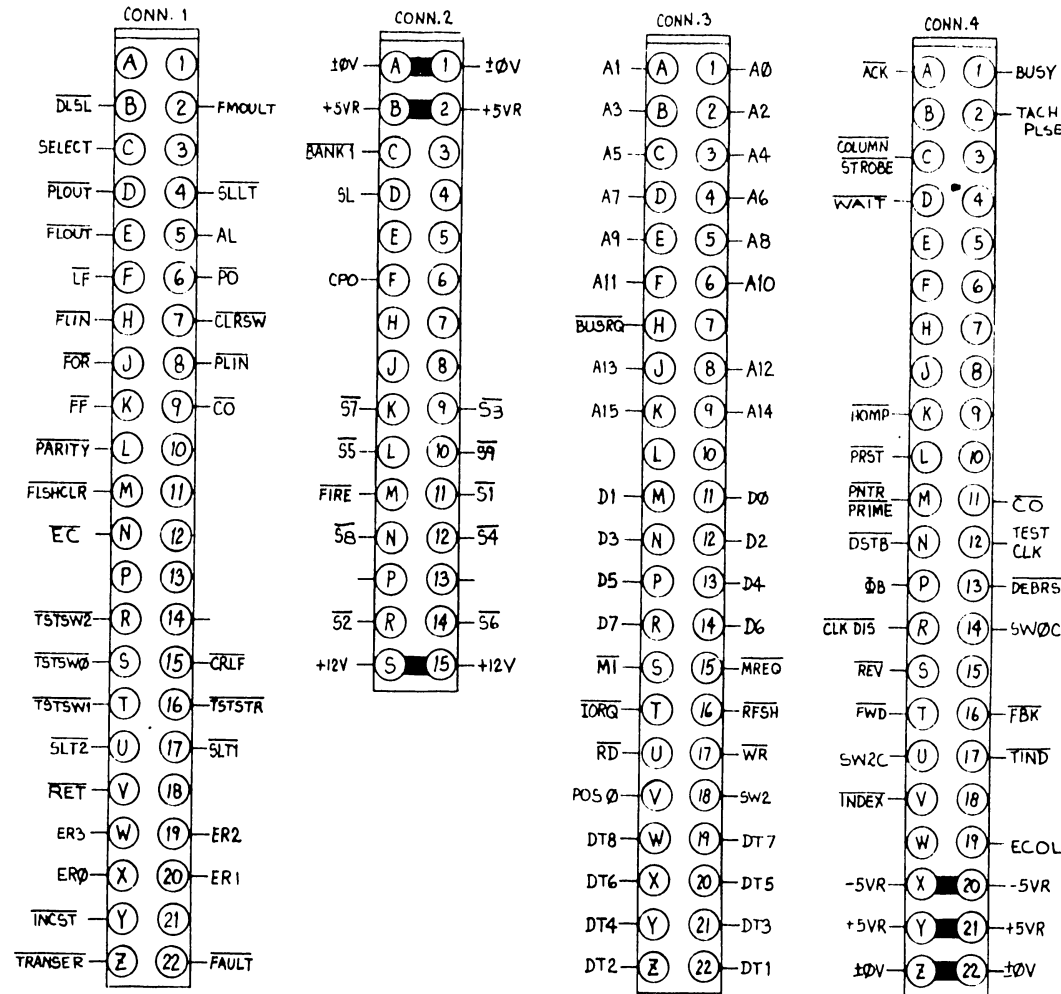

MNEMONIC	COORD	MNEMONIC	COORD
A0-A15	1E1	RD	1C1
ACK	2A6	RET	2D1
AL	4G1	REV	3F1
BANK 1	2G1	RFSH	1C1
BUSRQ	1C11	52, 54, 56, 58	4A4
BUSY	2A6	51, 53, 55, 57, 59	4E1
CLK DIS	1G9		
CLR SW	3C11	SLLT	1A7
CO	3F11	SELECT	1A7
CO	3D11	SL	4D1
COLUMN STROBE	3D1		
CPO	4D1	SLT1	1C11
CRLF	4C11	SLT2	1B11
DD-D7	1B1		
DEBRST	1E11	SW2	3A8
DSL	1A8	SW0C, SW2C	3B11
DSTB	2B11	TACH PLSE	1A7
DT1-DT8	2E11	TEST CLK	1G9
		TIND	3B1
		TRANSEK	4D1
ECOL	2G4	TSTSW0-TSTSW2	4C11
EC EVEN COUNTER	3A6	TSTSTR	4B11
ER0-ER3	4B1	WAIT	1D11
FAULT	4D1	WR	1C1
FBK	3A6		
FF	3C11		
FIRE	4B11		
FLIN	4B11		
FLOUT	4A9		
FISHLER	4C1		
FMOUT	3A7		
FOR	3C11		
FWD	3A6		
HOMP	3A5		
INCSTP	3G1		
INDEX	3G6		
TORG	1C1		
ΦB	3D1		
LF	3C11		
MT	1C1		
MREQ	1C1		
PARITY	4D1		
PLIN	4B11		
PLOUT	4A9		
PNTR PRIME	2C11		
PO	3D11		
POS0	3A7		
PRST	1A7		

I.C. TYPE	LOCATION	SPARE
4050	L67	2
	L68	2
7404	L30	1
	L55	2
74H04	L65	2
7406	L2	3
	L32	3
	L39	2
7408	L12	2
	L34	1
7410	L18	1
7414	L10	2
7427	L28	1
	L3	3
74279	L9	2
	L19	1
7432	L16	1
7474	L50	1
74LS74	L1	1
	L53	1
7486	L17	3
9602	L14	1
7400	L52	1

REV	DATE	BY	REASON
1	4-5-79
2	5-1-79
3	5-1-79
4	5-1-79
5	5-1-79
6	5-1-79
7	5-1-79
8	5-1-79
9	5-1-79
10	5-1-79
11	5-1-79
12	5-1-79
13	5-1-79
14	5-1-79
15	5-1-79
16	5-1-79
17	5-1-79
18	5-1-79
19	5-1-79
20	5-1-79
21	5-1-79
22	5-1-79
23	5-1-79
24	5-1-79
25	5-1-79
26	5-1-79
27	5-1-79
28	5-1-79
29	5-1-79
30	5-1-79

WANG LABORATORIES, INC.		BY: <i>DWR</i>	DATE: 3-13-80	APPROVED BY: <i>E ENGR M. H.</i>	DATE: 2/28/80
MODEL NO. 1022		TITLE: CPU & I/O			
SEE ENGR SPECIFICATIONS		DRAWING NUMBER: D 7593			
FINISH: 101 ± AS NOTED		SCALE: 1/8" = 1"			
112 ± FRACTION		SHEET 6 OF 7			
118 ± ANGLES		DRAWING NUMBER: D 7593			
SCALE: 1/8" = 1"		REV: 32			

THIS DRAWING AND THE DATA SHOWN THEREON ARE THE CONFIDENTIAL PROPERTY OF, AND ARE PROPRIETARY TO, WANG LABORATORIES, INC. THIS DRAWING AND THE DATA SHOWN THEREON MAY NOT BE MADE PUBLIC WITHOUT THE WRITTEN CONSENT OF WANG LABORATORIES, INC. IF FOR ANY REASON THIS DRAWING IS PERMITTED BY WANG TO LEAVE THE PHYSICAL CUSTODY OF THE COMPANY IT IS RETURNABLE UPON THE DEMAND OF WANG LABORATORIES, INC.

DO NOT SCALE

210 = 209 + 377 OR 378

210 = 209 + 377 OR 378

210	209	L42	L43	L44	L45	L47	L49
7593-A	7593			378-4244-R9	378-4243-R9	377-0368	377-0373
7593-B AMERICAN	7593	378-4266	378-4265	378-4244-R9	378-4243-R9	377-0368	377-0373
7593-C AZERTY	7593	378-4272	378-4271	378-4244-R9	378-4243-R9	377-0368	377-0373
7593-D GERMAN	7593	378-4274	378-4273	378-4244-R9	378-4243-R9	377-0368	377-0373
7593-E GREEK-LATIN	7593	378-4276	378-4275	378-4244-R9	378-4243-R9	377-0368	377-0373
7593-F ICELAND	7593	378-4278	378-4277	378-4244-R9	378-4243-R9	377-0368	377-0373
7593-G DUTCH	7593	378-4280	378-4279	378-4244-R9	378-4243-R9	377-0368	377-0373
7593-H NORWAY	7593	378-4282	378-4281	378-4244-R9	378-4243-R9	377-0368	377-0373
7593-J SWISS	7593	378-4286	378-4285	378-4244-R9	378-4243-R9	377-0368	377-0373
7593-K SWEDEN	7593	378-4288-R1	378-4287-R1	378-4244-R9	378-4243-R9	377-0368	377-0373
7593-L UNITED KINGDOM	7593	378-4290	378-4289	378-4244-R9	378-4243-R9	377-0368	377-0373
7593-M SPAIN	7593	378-4284	378-4283	378-4244-R9	378-4243-R9	377-0368	377-0373
7593-S CANADIAN	7593	378-4292	378-4291	378-4244-R9	378-4243-R9	377-0368	377-0373
7593-U MIDDLE EAST	7593	378-4293	378-4271	378-4385	378-4384	377-0368	377-0373
7593-V KATAKANA	7593		378-4300	378-4244-R9	378-4243-R9	377-0368	377-0373
7593-X CYRILLIC FONT	7593	378-5039	378-4294-R1	378-4244-R9	378-4243-R9	377-0368	377-0373
7593-Y AFRICAN	7593	378-4298	378-4296	378-4244-R9	378-4243-R9	377-0368	377-0373
7593-Z CYRILL FONT	7593	378-5039	378-4294-R1	378-4244-R9	378-4243-R9	377-0368	377-0373

210	209	L42	L43	L44	L45	L47	L49
7593-1A	7593-1			378-4246-R9	378-4245-R9	377-0344	377-0373
7593-1B AMERICAN	7593-1	378-4264	378-4263	378-4246-R9	378-4245-R9	377-0368	377-0373
7593-1C E. EUROPE	7593-1	378-4268	378-4267	378-4246-R9	378-4245-R9	377-0368	377-0373
7593-1D GREEK WP, Q, S	7593-1		378-4269	378-4246-R9	378-4245-R9	377-0368	377-0373
7593-1E KATAKANA	7593-1		378-4300	378-4246-R9	378-4245-R9	377-0368	377-0373
7593-1F LATIN ARABIC	7593-1	378-4297	378-4299	378-4246-R9	378-4245-R9	377-0368	377-0373

NO	DATE	DESCRIPTION

(WANG) LABORATORIES, INC. LONDON, MASS. U.S.A.		BY DWN BK	DATE 4-28-81	APPROVED BY	DATE
MATERIAL		CHK		ENGR	
MODEL NO. 1022		TITLE CPU I/O			
FINISH		SEE CHART D		7593	32
SCALE 1/4" = 1"		SHEET 7 OF 7		WANG PART NUMBER	DRAWING NUMBER

D 7593

A

A

THIS DRAWING AND THE DATA SHOWN THERE ON ARE THE CONFIDENTIAL PROPERTY OF AND ARE PROPRIETARY TO WANG LABORATORIES, INC. THIS DRAWING AND THE DATA SHOWN THEREON MAY NOT BE MADE PUBLIC WITHOUT THE WRITTEN CONSENT OF WANG LABORATORIES, INC. IF FOR ANY REASON THIS DRAWING IS PERMITTED BY WANG TO LEAVE THE PHYSICAL CUSTODY OF THE COMPANY, IT IS RETURNABLE UPON THE DEMAND OF WANG LABORATORIES, INC.

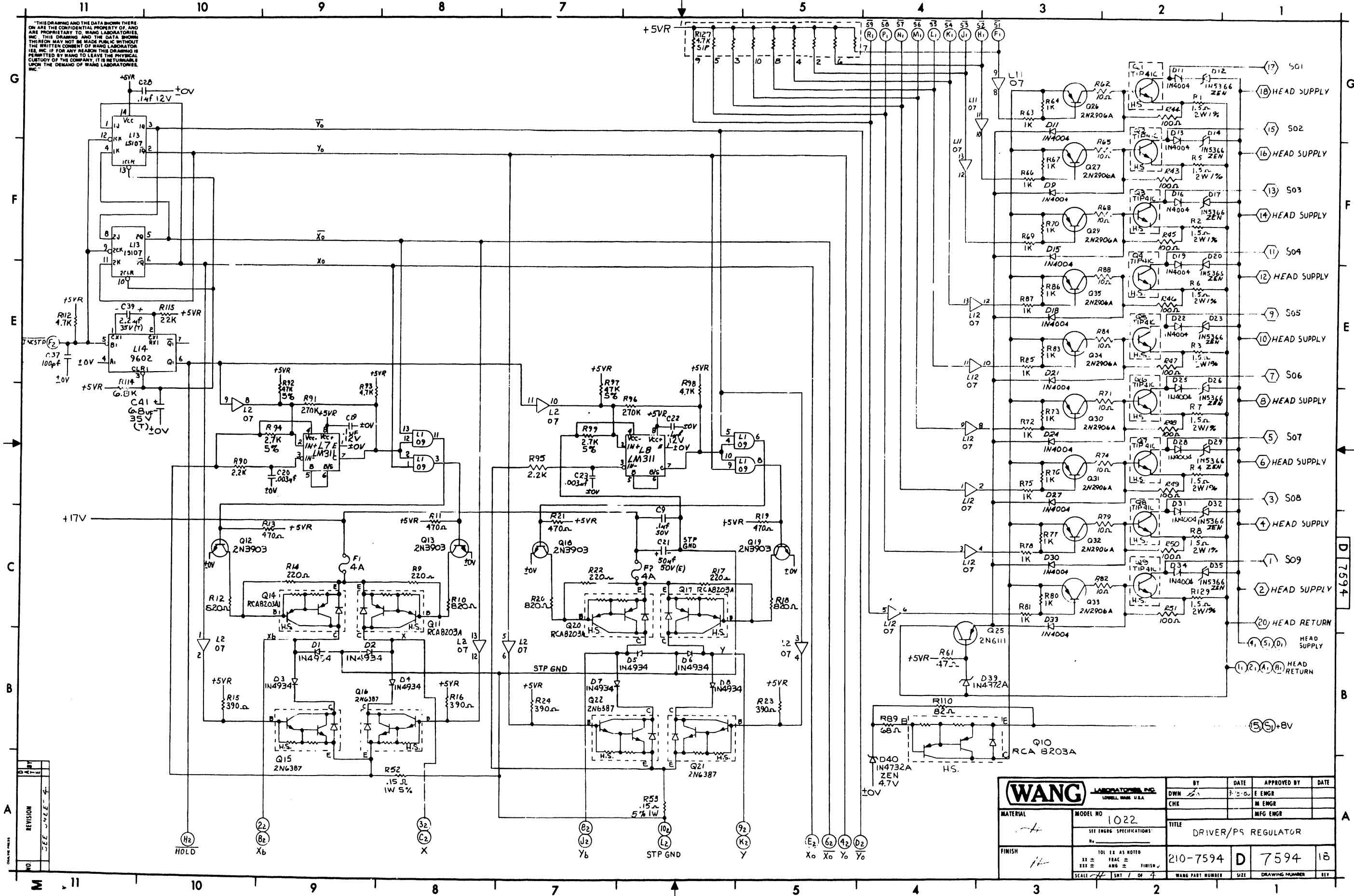

WANG LABORATORIES, INC. LOWELL, MASS. U.S.A.		BY	DATE	APPROVED BY	DATE
MATERIAL	MODEL NO. 1022	DWN	7-5-64	E ENGR	
FINISH	SEE ENGR SPECIFICATIONS	CHK		M ENGR	
TITLE DRIVER/PS REGULATOR		210-7594 D		7594	18
SCALE 1/1		WANG PART NUMBER		SIZE	DRAWING NUMBER

THIS DRAWING AND THE DATA SHOWN THEREON ARE THE CONFIDENTIAL PROPERTY OF, AND ARE PROPRIETARY TO, WANG LABORATORIES, INC. THIS DRAWING AND THE DATA SHOWN THEREON MAY NOT BE MADE PUBLIC WITHOUT THE WRITTEN CONSENT OF WANG LABORATORIES, INC. IF FOR ANY REASON THIS DRAWING IS PERMITTED BY WANG TO LEAVE THE PHYSICAL CUSTODY OF THE COMPANY, IT IS RETURNABLE UPON THE DEMAND OF WANG LABORATORIES, INC.

DO NOT SCALE

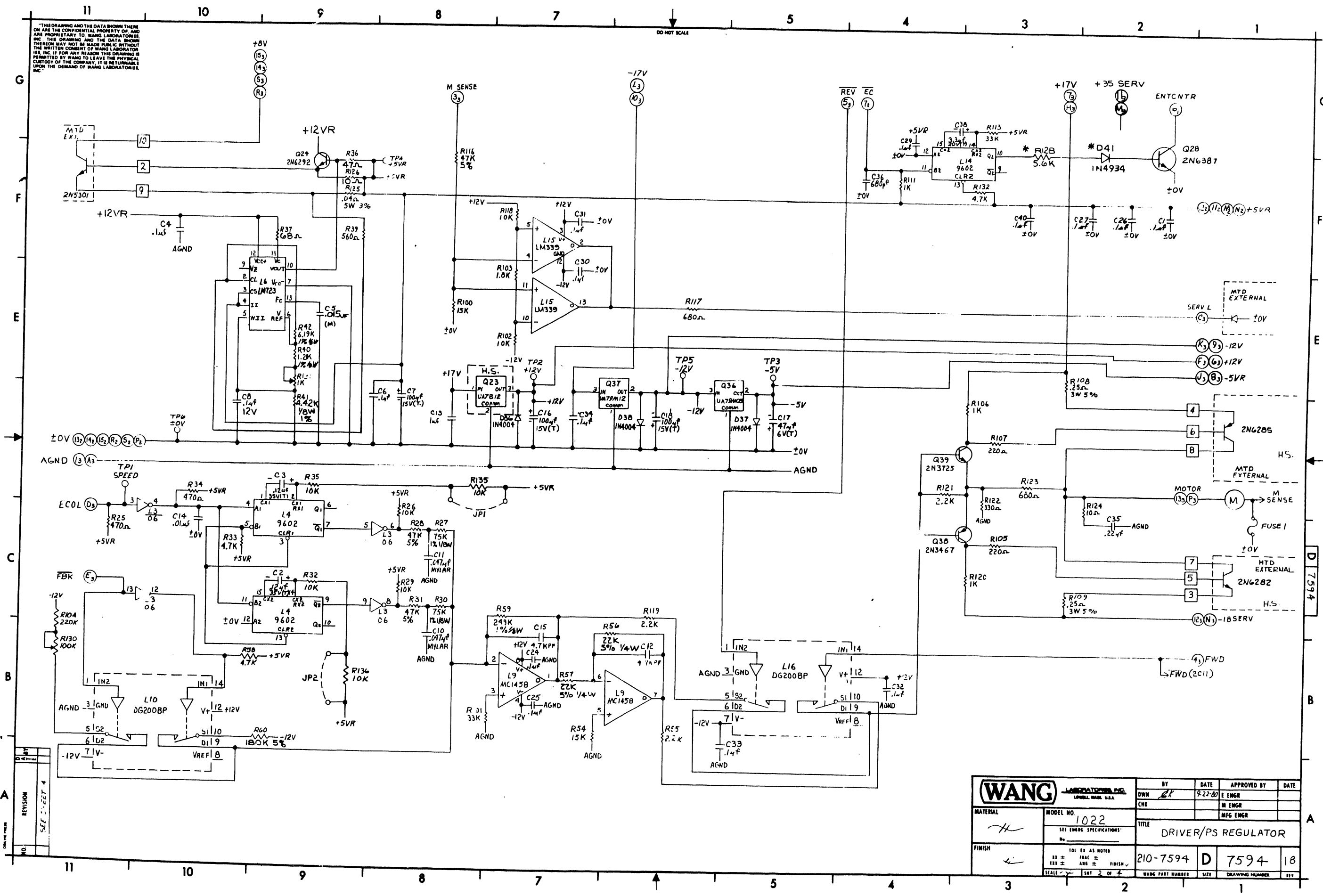

WANG LABORATORIES, INC. LIPSHILL, MASS. U.S.A.		BY DWN	DATE 9-27-60	APPROVED BY E ENGR	DATE
MATERIAL CHK	MODEL NO. 1022 SEE ENGR SPECIFICATIONS	CHK		M ENGR	
FINISH ✓	101 EE AS NOTED 102 ± FRAC ± 103 ± ANG ± FINISH ✓	TITLE DRIVER/PS REGULATOR	210-7594	D	7594 18
SCALE 1/8" = 1"	SHEET 2 OF 4	WANG PART NUMBER	SIZE	DRAWING NUMBER	DIV

11 10 9 8 7 5 4 3 2 1

THIS DRAWING AND THE DATA SHOWN THERE ON ARE THE CONFIDENTIAL PROPERTY OF, AND ARE PROPRIETARY TO, WANG LABORATORIES, INC. THIS DRAWING AND THE DATA SHOWN THEREON MAY NOT BE MADE PUBLIC WITHOUT THE WRITTEN CONSENT OF WANG LABORATORIES, INC. IF FOR ANY REASON THIS DRAWING IS PERMITTED BY WANG TO LEAVE THE PHYSICAL CUSTODY OF THE COMPANY, IT IS RETURNABLE UPON THE DEMAND OF WANG LABORATORIES, INC.

REFERENCE:
 1. Q1-Q11, Q14-Q17, Q20-Q24 HAS HEATSINK PAD 375-9034, WASHER 375-9036 & SCREWS 650-2127.

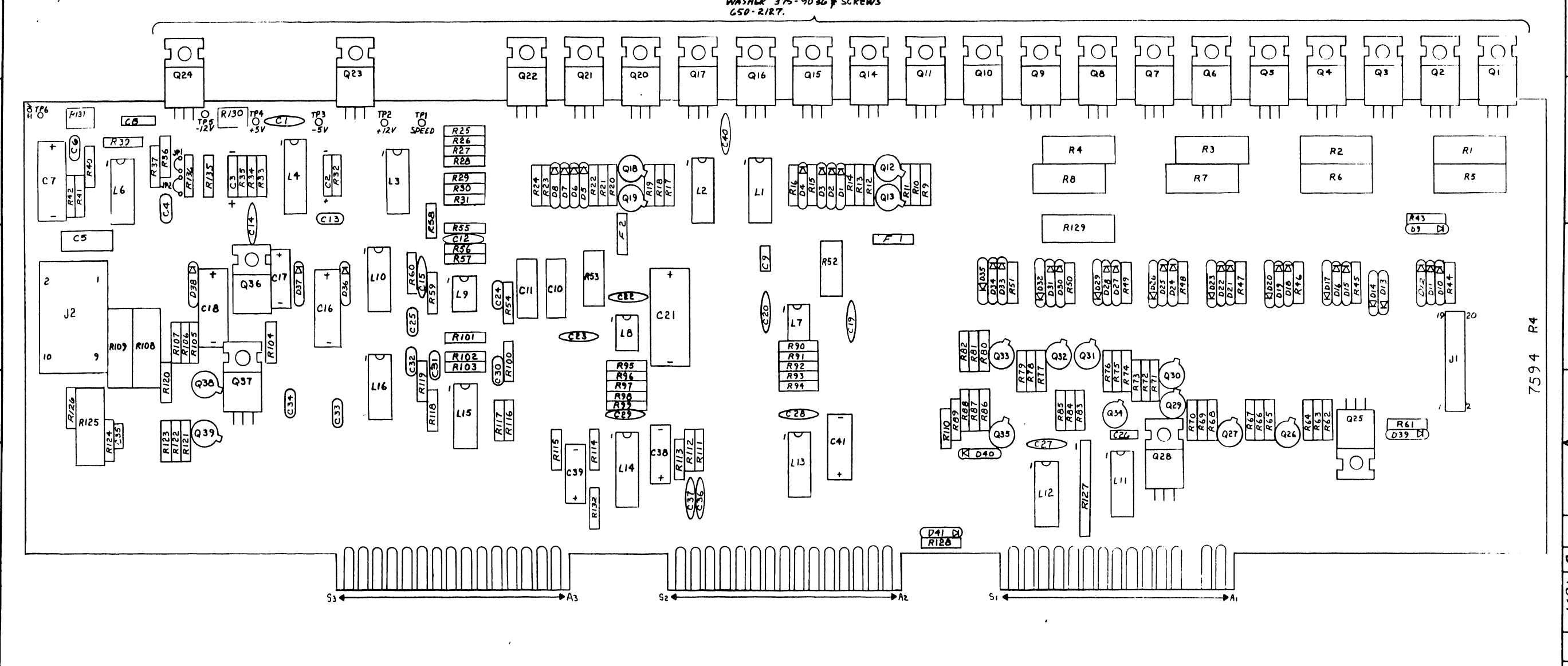

REFERENCE:
 2. Q28, Q36, Q37 HAS HEATSINK PAD 375-9034 SCREWS 650-2128 AND NUTS 652-2004.
 3. Q25 HAS SCREW 650-2128 AND NUT 652-2004.

REV	BY	DATE
1		
2		
3		
4		

WANG LABORATORIES, INC. LOWELL, MASS. U.S.A.		BY DWN	DATE 7-24-80	APPROVED BY E ENGR	DATE
MATERIAL #	MODEL NO. 1022	CHE		MFG ENGR	
SEE ENGR SPECIFICATIONS		TITLE DRIVERS/PS REGULATOR			
FINISH #	TOL EX AS NOTED XX ± FRACTION ± FINISH XXX ± ANG ±	210-7594	D	7594	18
SCALE 1/8" = 1"		SHT 3 OF 4	WANG PART NUMBER	SIZE	DRAWING NUMBER

11 10 9 8 7 5 4 3 2 1

THIS DRAWING AND THE DATA SHOWN THEREON ARE THE CONFIDENTIAL PROPERTY OF AND ARE PROPRIETARY TO WANG LABORATORIES, INC. THIS DRAWING AND THE DATA SHOWN THEREON MAY NOT BE MADE PUBLIC WITHOUT THE WRITTEN CONSENT OF WANG LABORATORIES, INC. IF FOR ANY REASON THIS DRAWING IS PERMITTED BY WANG TO LEAVE THE PHYSICAL CUSTODY OF THE COMPANY, IT IS RETURNABLE UPON THE DEMAND OF WANG LABORATORIES, INC.

COMPONENT	W.L. PART NO.	TYPE
R37,89	330-106B	68Ω 1/4W 10%
R1-8,129	334-0026	15Ω 2W 1%
R9,14,17,22,105,107	330-202R	220Ω 1/4W 10%
R11,13,19,21,25,24	330-2047	470Ω 1/4W 10%
R15,16,23,24	330-2039	390Ω 1/4W 10%
R26,29,32,35,102,118,135,136	330-4010	10K 1/4W 10%
R27,30	333-0065	75K 1/8W 1%
R28,31	330-404B	47K 1/4W 5%
R33,58,93,98,112,132	330-3047	4.7K 1/4W 10%
R63,64,66,67,69,79,72,73,75-78,80,81,83,85-87,106,114,120	330-3010	1K 1/4W 10%
R39	330-2056	560Ω 1/4W 10%
R40	333-0106	1.2K 1/8W 1%
R41	333-0170	4.42 1/8W 1%
R42	333-0069	619K 1/8W 1%
R43-51	330-2010	100Ω 1/4W 10%
R52,53	334-0053	.15Ω 1W 5%
R54,100	330-4015	15K 1/4W 10%
R55,90,95,119,121	330-3022	2.2K 1/4W 10%
R56,57	330-4023	22K 1/4W 5%
R59	333-0062	249K 1/8W 1%
R60	330-5019	180K 1/4W 5%
R62,65,68,71,74,79,82,84,88,124,126	330-1010	10Ω 1/4W 10%
R91,96	330-5027	270K 1/4W 10%
R92,97,116	330-404B	47K 1/4W 5%
R94,99	330-302B	2.7K 1/4W 5%
R101,113	330-4033	33K 1/4W 10%
R104	330-5022	220K 1/4W 10%
R108,109	334-0017	.25Ω 3W 5%
R115	330-4022	22K 1/4W 10%
R117,123	330-206B	680Ω 1/4W 10%
R122	330-2033	330Ω 1/4W 10%
R125	334-0030	.04Ω 5W 3%
R128	330-3056	5.6K 1/4W 10%
R130	336-1019	100K POT
R131	336-1014	1K POT
R36,61	330-1047	47Ω 1/4W 10%
C1,8,19,22,26-29,40	300-1901	.1μF 12V
C2,3	300-4003	.12μF 35V(T)
C25	300-1913-1	.1μF 25V
C9	300-1930	.1μF 50V
C7,16,18	300-4021	100μF 15V(T)
C10,11	300-2147	.047μF 100V(M)
C12,15	300-1932	4.7KμF 100V
C14	300-1903	.01μF 25V
C17	300-4049	47μF 6V(T)
C20,23	300-1905	.003μF 100V
C21	300-3010	50μF 50V(E)
C35	300-1926	.22μF 100V
C36	300-1680	680μF 500V
C37	300-1100	100μF 500V
C38	300-4022	3.3μF 20V(T)
C39	300-4027	2.2μF 35V(T)

COMPONENT	W.L. PART NO.	TYPE
D1-8,41	380-4011	1N4934
D9-11,13,14,16,18,19,21,22,24,25,27,28,30,31,33,34,36-38	380-4000	1N4004
D40	380-2135	1N4732A 4.7V
D12,14,17,20,23,26,29,32,35	380-2141	1N5366 39V
D39	380-2129	1N4372A
F1,2	360-1156	4 AMP 125V
Q1-9	375-1106	TIP 41C
Q10,11,14,17,20	375-1053	RCAB203A
Q12,13,18,19	375-1068	2N3903
Q15,16,21,22,28	375-1052	2N6387
Q23	374-0000	MA7812
Q24	375-1051	2N6292
Q25	375-1034	2N6111
Q26,27,29-35	375-1017	2NE906A
Q36	374-0012	MA79M05
Q37	374-0019	MA79M12
Q38	375-1026	2N3467
Q39	375-1027	2N3725
J1	350-0211	20 PIN 90°
J2	654-118B	10 PIN

IC LOCATION	W.L. PART NO.	TYPE
L1	376-0085	7409
L2,11,12	376-0056	7407
L3	376-0055	7406
L4,14	376-0104	7402
L5		SPARE
L6	376-0478	LM723
L7,8	376-0474	LM311
L9	376-0265	MC1458
L10,16	376-0480	DG 300BP
L13	376-0490	74LS107
L15	376-0240	LM339

COMPONENT	W.L. PART NO.	TYPE
R10,12,18,20	330-2082	820Ω 1/4W 10%
R127	333-0812	4.7K SIP
R110	330-1082	82Ω 1/4W 10%
R103	330-3018	1.8K 1/4W 10%
R114	330-3068	6.8K 1/4W 10%
C4,6,24,25,30-34	300-1930	.1μF 50V
C5	300-2115	.015μF 100V(M)
C13	300-1931	1μF 50V
C41	300-403B	6.8μF 35V(T)

DO NOT SCALE

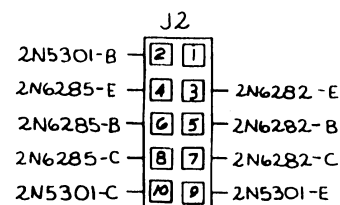
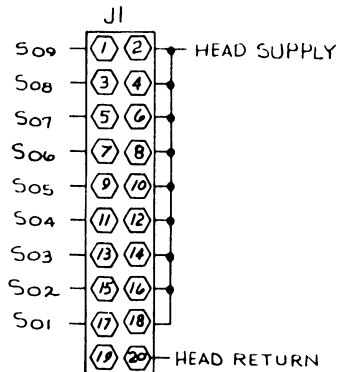

IC TYPE	LOCATION	SPARE
7400	L5	1
7406	L3	2
7407	L11	3
LM339	L15	2

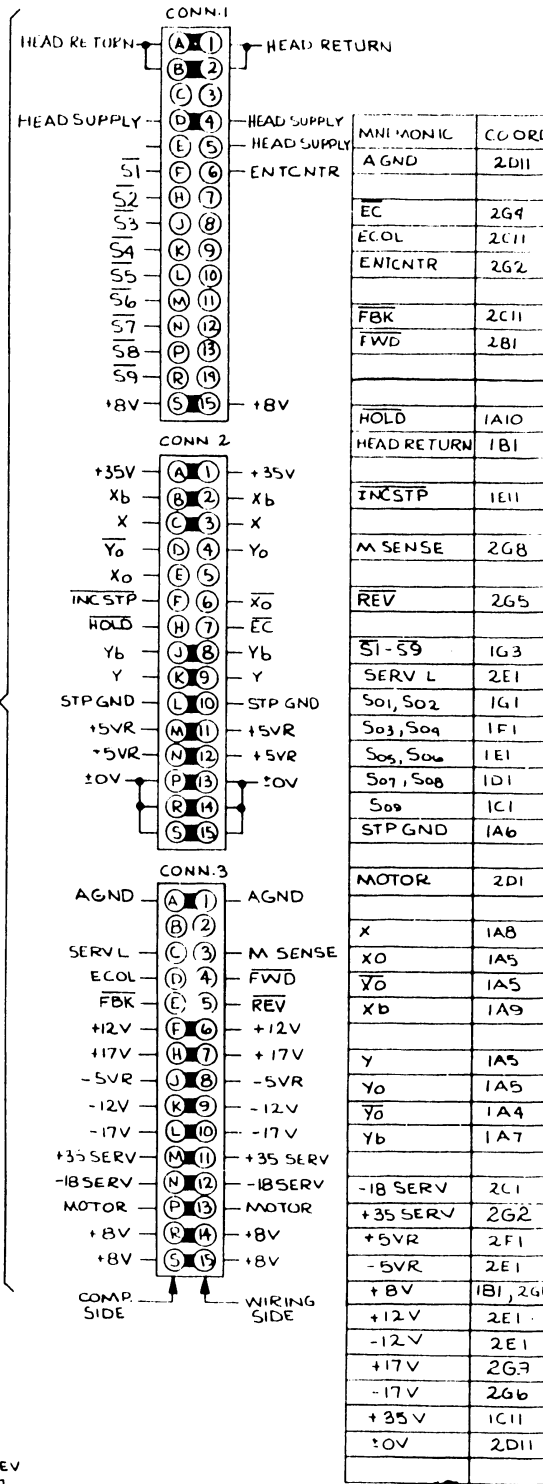

E-REV
10

REVISED PER	DATE	BY	APP'D.	REVISED PER	DATE	BY	APP'D.
1	10/24/80	WEP	190	1	10/24/80	WEP	190
2	11/21/80	WEP	190	2	11/21/80	WEP	190
3	12/15/80	WEP	190	3	12/15/80	WEP	190
4	1/14/81	WEP	190	4	1/14/81	WEP	190
5	2/5/81	WEP	190	5	2/5/81	WEP	190
6	3/13/81	WEP	190	6	3/13/81	WEP	190
7	4/17/81	WEP	190	7	4/17/81	WEP	190
8	5/12/81	WEP	190	8	5/12/81	WEP	190
9	6/11/81	WEP	190	9	6/11/81	WEP	190
10	7/16/81	WEP	190	10	7/16/81	WEP	190
11	8/19/81	WEP	190	11	8/19/81	WEP	190
12	9/14/81	WEP	190	12	9/14/81	WEP	190
13	10/14/81	WEP	190	13	10/14/81	WEP	190
14	11/17/81	WEP	190	14	11/17/81	WEP	190
15	12/21/81	WEP	190	15	12/21/81	WEP	190
16	1/13/82	WEP	190	16	1/13/82	WEP	190
17	2/10/82	WEP	190	17	2/10/82	WEP	190
18	3/10/82	WEP	190	18	3/10/82	WEP	190
19	4/15/82	WEP	190	19	4/15/82	WEP	190
20	5/18/82	WEP	190	20	5/18/82	WEP	190
21	6/18/82	WEP	190	21	6/18/82	WEP	190

WANG		LABORATORIES, INC.		BY	DATE	APPROVED BY	DATE
		LOWELL, MASS. U.S.A.		DWN SEP	11-24-82	E ENGR	11/24/82
MATERIAL		MODEL NO. 1022		CHE J.P. BRATT	2-12-82	M ENGR	
FINISH		SEE ENGR SPECIFICATIONS		TITLE DRIVER/PS REGULATOR			
		TOLERANCES UNLESS NOTED		210-7594	D	7594	18
		SCALE 1/8" = 1"		DATE PART BOMME	SIZE	DRAWING NUMBER	REV

	11	10	9	8	7	6	5	4	3	2	1
G											
F											
E											
D											
C											
B											
A											

THIS DRAWING AND THE DATA SHOWN THERE ON ARE THE CONFIDENTIAL PROPERTY OF AND PROPRIETARY TO WANG LABORATORIES, INC. THIS DRAWING AND THE DATA SHOWN THEREIN MAY NOT BE MADE PUBLIC WITHOUT THE WRITTEN CONSENT OF WANG LABORATORIES, INC. IF FOR ANY REASON THIS DRAWING IS PERMITTED BY WANG TO LEAVE THE PHYSICAL CUSTODY OF THE COMPANY, IT IS RETURNABLE UPON THE DEMAND OF WANG LABORATORIES, INC.

DO NOT SCALE

NOTE: (1) LABELS WITHIN PARENTHESIS BELONG TO 7348, 7547, 7446 CARDS ONLY.

WANG LABORATORIES, INC. LOWELL, MASS. U.S.A.		BY DWN	DATE 7/1/75	APPROVED BY M ENGR	DATE
MATERIAL		CHK		MFG ENGR	
MODEL NO. 1022 SEE ENGR SPECIFICATIONS		TITLE MOTHERBOARD			
FINISH 101 IS AS NOTED 23 ± 33 ± 51 ± ANG ± SCALE 1/8" = 1" FINISH		210-7595	D	75 95	6
WANG PART NUMBER		SIZE	DRAWING NUMBER		REV

5651 D

	7370 CPU MEM		7347 I/O MEM		7346 SPARE TEST MEM		7393 CPU DRIVER		J1	J2	J3	J4	J5	J6	J7	J8	J9	J10	S.P.
DSTB (DATA STB)																			
DT1 (DATA)			J1																
DT2 (DATA)			H1																
DT3 (DATA)			31																
DT4 (DATA)			D1																
DT5 (DATA)			Z1																
DT6 (DATA)			Y1																
DT7 (DATA)			X1																
DT8 (DATA)			W1																
ECOL					13														
ER0																			
ER1																			
ER2																			
ER3																			
EC																			
EVNT CNTR																			
FAULT (CHK)																			
FBRK																			
FF (TOF)																			
FIRE																			
FLIN (FL)																			
FLOUT																			
FMULT																			
FOR																			
FWD																			
+GA																			+GA
+GB																			+GB
HOLD																			
HOMIP																			
IMCST																			
INDEX																			
IMP																			
IMPRIME																			
INST																			
INST R/B																			
IORG																			
IS																			
LF																			
LINE ERROR																			
LOSVP																			
MI																			
M + RED																			
MEDIN																			
MEM PAR																			
MEM WD																			
MR																			
MREQ																			
OUT																			
PARRY (CAR)																			
PE																			
PLIN (PL)																			
PLOUT																			
PO																			
POSO																			
PROM																			
PRST																			
-RA																			
-RB																			
RC																			
RD																			
REC																			
RECINT																			
REF																			
REF																			
RESTART																			
REJ(DATA)																			
REV																			
RF5H																			

NOTE: (1) LABELS WITHIN PARENTHESIS BELONG TO 734B, 7547, 7446 CARDS ONLY.

THIS DRAWING AND THE DATA SHOWN THEREON ARE THE CONFIDENTIAL PROPERTY OF AND ARE PROPRIETARY TO WANG LABORATORIES INC. THIS DRAWING AND THE DATA SHOWN THEREON MAY NOT BE MADE PUBLIC WITHOUT THE WRITTEN CONSENT OF WANG LABORATORIES INC. IF FOR ANY REASON THIS DRAWING IS WRITTEN BY WANG TO LEAVE THE PHYSICAL CUSTODY OF THE COMPANY IT IS TO REMAIN THE PROPERTY OF WANG LABORATORIES INC.

WANG LABORATORIES LOWELL, MASS. U.S.A.		BY <u>DWN</u>	DATE <u>7/7/70</u>	APPROVED BY	DATE
MATERIAL	MODEL NO. <u>1022</u>	CHE		M ENGR	
SEE ENG'G SPECIFICATIONS				MFG ENGR	
FINISH	TOL. AS NOTED	TITLE <u>MOTHERBOARD</u>			
	SEE ENGR'G SPEC.	<u>210-7595</u>	<u>D</u>	<u>7595</u>	<u>6</u>
	SCALE <u>1/2</u> OF <u>4</u>	WANG PART NUMBER		SIZE	DRAWING NUMBER

56-51-D

THIS DRAWING AND THE DATA SHOWN THERE ON ARE THE CONFIDENTIAL PROPERTY OF AND ARE PROPRIETARY TO WANG LABORATORIES, INC. THIS DRAWING AND THE DATA SHOWN THEREON MAY NOT BE MADE PUBLIC WITHOUT THE WRITTEN CONSENT OF WANG LABORATORIES, INC. IF FOR ANY REASON THIS DRAWING IS PERMITTED BY WANG TO LEAVE THE PHYSICAL CUSTODY OF THE COMPANY, IT IS RETURNABLE UPON THE DEMAND OF WANG LABORATORIES.

DO NOT SCALE

	J1	J2	J3	J4	J5	J6	J7	J8	J9
7348 CPU MEM									
7547 CPU MEM									
7746 CPU MEM									
7594 CPU DRIVER	F1								
7593 CPU DRIVER	H1								
SPARE MEM									
SPARE TEST									
SELECT									
SERV-L									
SELC									
SLT1 (SEL)									
SLT2 (SEL)									
HEAD RETURN									
SRL									
STATUS									
STCL									
SW2									
SW6C									
SW2C									
SYNC									
T1									
TC									
TCB									
TEST CLK									
TIND									
±OV									
TEST SW1									
TEST SW2									
TEST SW3									
TRANSER (PWR)									
WR									
WR									
VRT									
X									
X0									
X0									
XB									
Y									
Y0									
Y0									
YA									
Ø1A									
Ø2									
M SENSE									
ØB									
M SENSE									
+12V									
+17V									
-5VR									
-12V/-18V									
+8V									
+35V									
+5VR									

J10

NOTE: (1) LABELS WITHIN PARENTHESIS BELONG TO 7348, 7547, 7446 CARDS ONLY.

WANG LABORATORIES, INC. MODEL NO. 1022		BY: <i>DR</i>	DATE: 7/1/68	APPROVED BY:	DATE:
TITLE: MOTHERBOARD		OWN: DR	ENGR: E ENGR		
DRAWING NO. 7595 D					
DRAWING NO. 7595 6					

NO.	REVISION
1	SEE 547

THIS DRAWING AND THE DATA SHOWN THEREON ARE THE CONFIDENTIAL PROPERTY OF, AND ARE PROPRIETARY TO, WANG LABORATORIES, INC. THIS DRAWING AND THE DATA SHOWN THEREON MAY NOT BE MADE PUBLIC WITHOUT THE WRITTEN CONSENT OF WANG LABORATORIES, INC. IF FOR ANY REASON THIS DRAWING IS PERMITTED BY WANG TO LEAVE THE PHYSICAL CUSTODY OF THE COMPANY, IT IS RETURNABLE UPON THE DEMAND OF WANG LABORATORIES, INC.

DO NOT SCALE

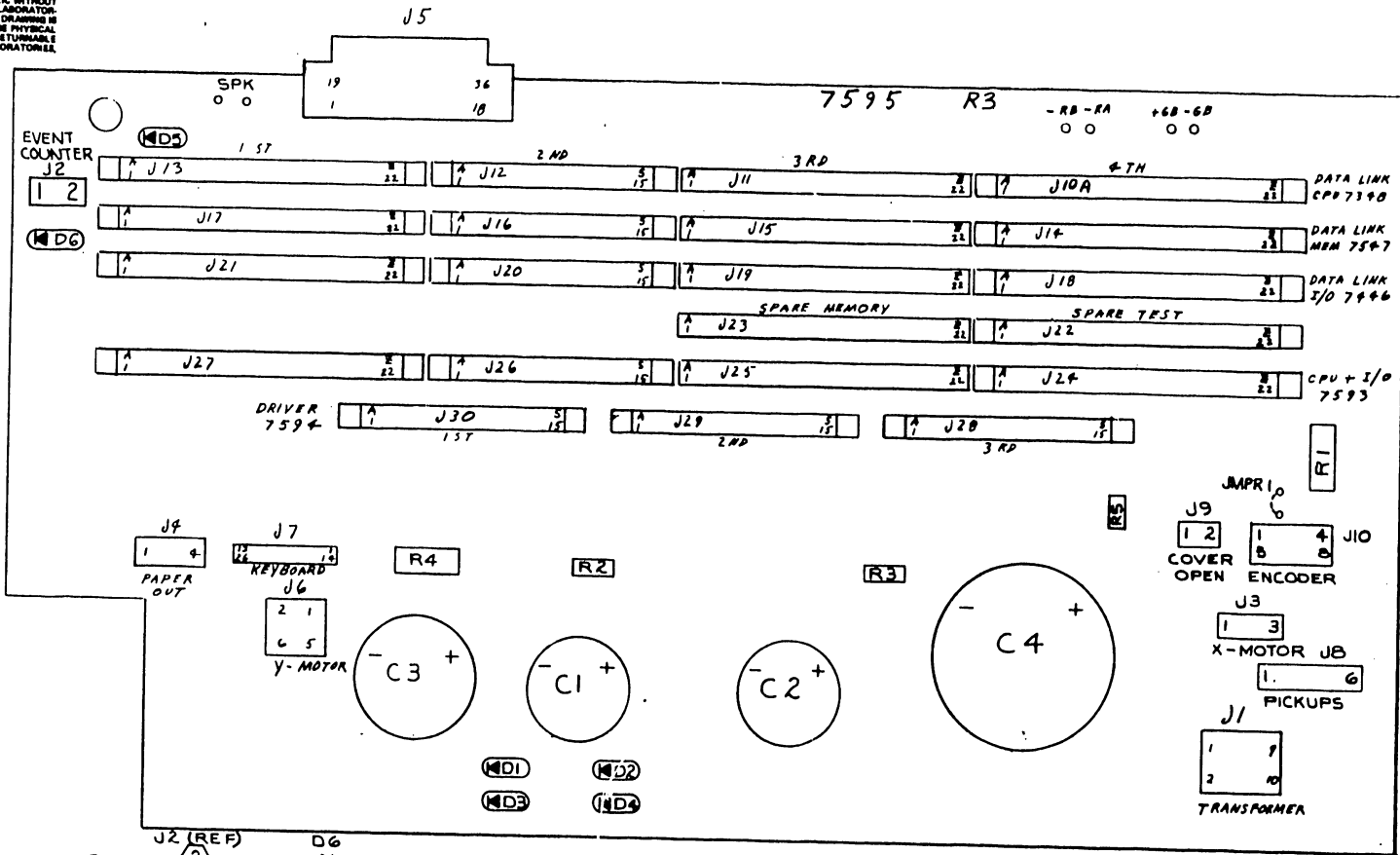

COMPONENT	W.L. PART NO	TYPE
R1	331-2033	330 Ω 1/2 W 10%
R2, 3, 5	331-3022	2.2 K 1/2 W 10%
R4	332-3022	22 K 1 W 10%
C1, 2	300-3076	12 K M F 25 V ELECT
C3	300-3316	20 K M F 60 V ELECT
C4	300-3070	53 K M F 25 V ELECT
D1-4	380-3002	1N4719
D5, 6	380-4000	1N4004
J1	654-1188	10 POS HEADER
J2, 9	654-1198	2 POS HEADER
J4	654-1194	4 POS HEADER
J5	350-1060	36 PIN CONN.
J6	654-1186	6 POS HEADER
J7	650-0200	26 PIN CONN.
J10A, 13, 14, 17, 18, 21, 22, 24, 27	350-0021	44 PIN CONN.
J11, 15, 19, 23, 25	350-0039	44 PIN CONN.
J12, 16, 20, 26, 28, 29, 30	350-0011	30 PIN CONN.
J3	654-1193	3 PIN AMP
J8	654-0106	6 PIN AMP
J10	350-0212	8 PIN AMP

NOTE:-
 1. 92B, VS SERIAL VERSION DO NOT LOAD J5 AND J23
 2. 220C PARALLEL VERSION DO NOT LOAD DATA LINK CONNECTORS J10 THRU J21, J23.

LOADING VARIATION CHART				
7595	C1-4	R1-5	D1-6	J1-10, J22, 24-30
7595-1	C1-4	R1-5	D1-6	J1-4, J6-22, J24-30

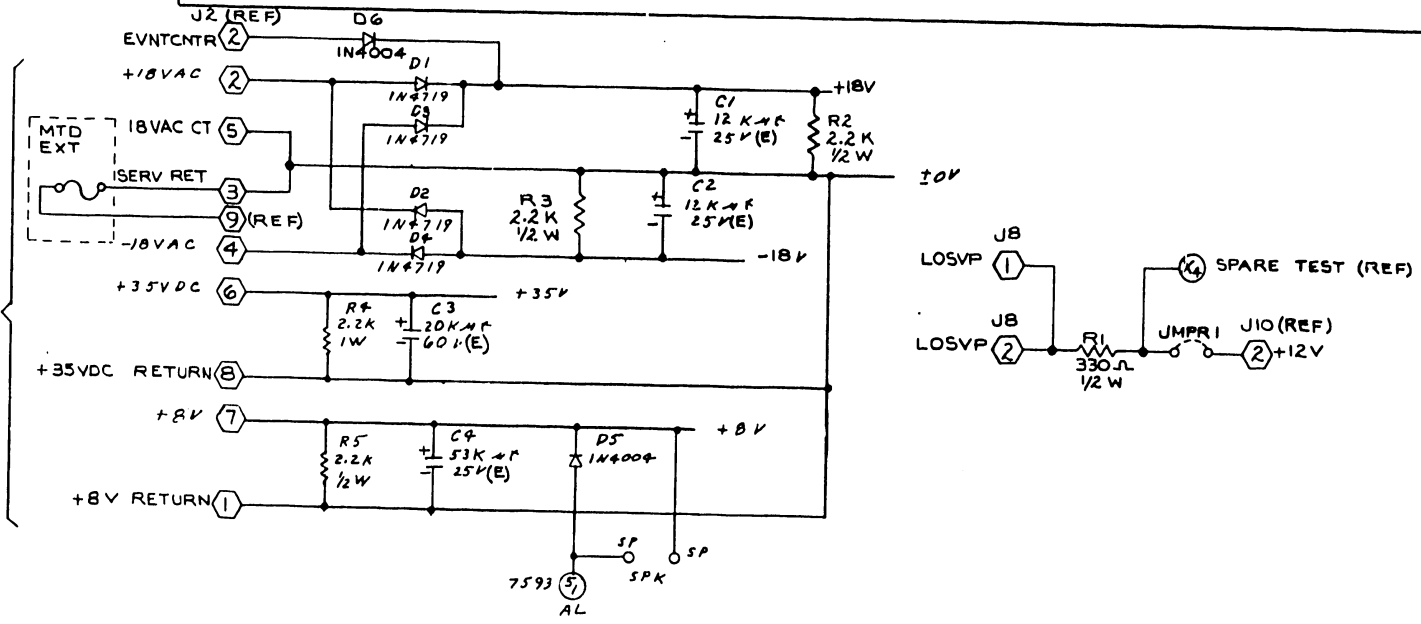

REV	DATE	BY	CHK	APP'D	REVISION
1	1/17/68	DWN	REVISED PER ECN # 15030
2	1/22/68	DWN	REVISED PER ECN # 15030
3	1/22/68	DWN	REVISED PER ECN # 15030
4	1/22/68	DWN	REVISED PER ECN # 15030
5	1/22/68	DWN	REVISED PER ECN # 15030
6	1/22/68	DWN	REVISED PER ECN # 15030

WANG LABORATORIES, INC.
 MODEL NO. 1022
 TITLE: MOTHERBOARD
 210-7595 D 7595 6
 WANG PART NUMBER SIZE DRAWING NUMBER REV.

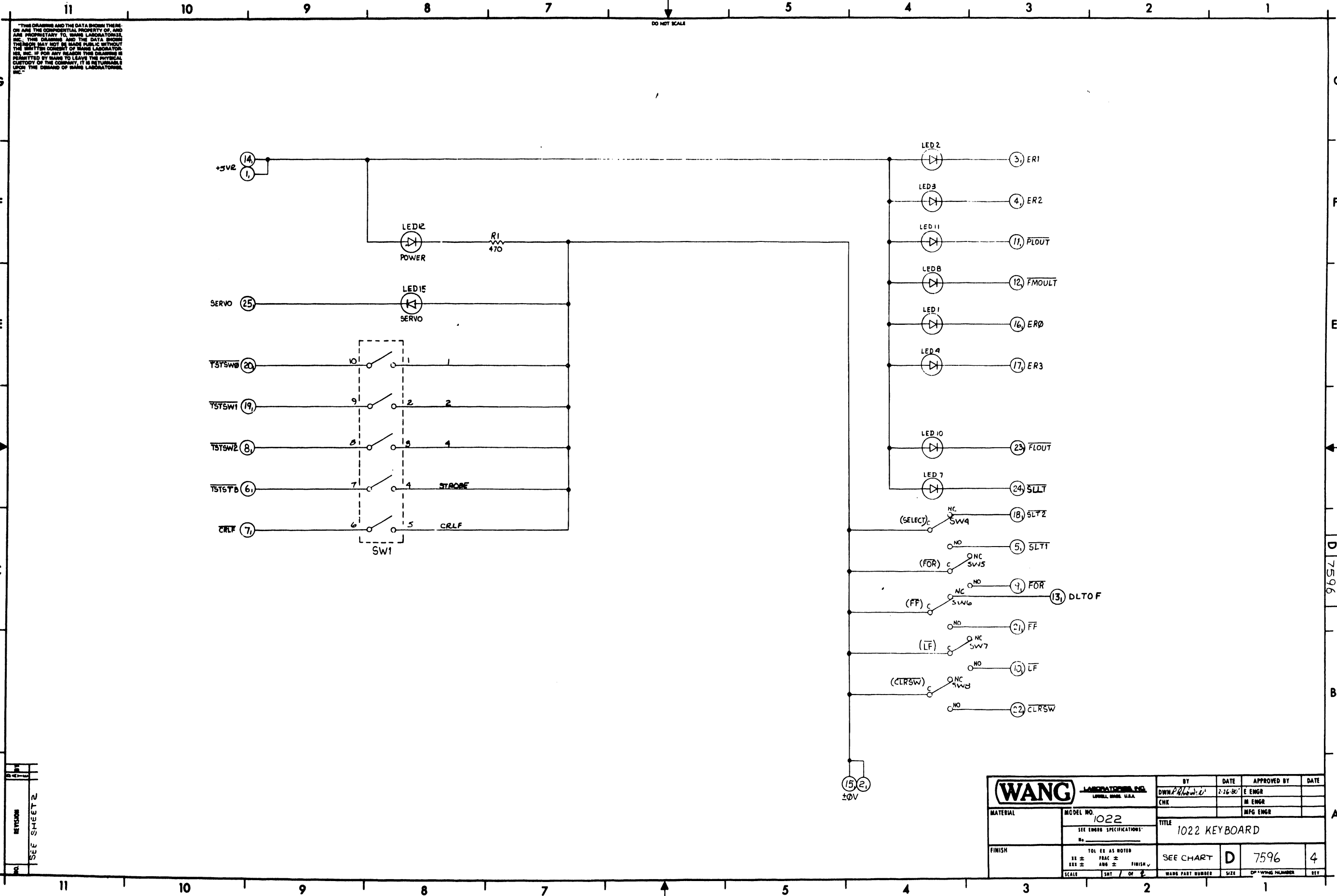

"THE DRAWING AND THE DATA SHOWN THEREON ARE THE CONFIDENTIAL PROPERTY OF, AND ARE PROPRIETARY TO, WANG LABORATORIES, INC. THIS DRAWING AND THE DATA SHOWN THEREON MAY NOT BE MADE PUBLIC WITHOUT THE WRITTEN CONSENT OF WANG LABORATORIES, INC. IF FOR ANY REASON THIS DRAWING IS PERMITTED BY WANG TO LEAVE THE PHYSICAL CUSTODY OF THE COMPANY, IT IS RETURNABLE UPON THE DEMAND OF WANG LABORATORIES, INC."

DO NOT SCALE

REVISION	DATE	BY

SEE SHEET 2

WANG LABORATORIES, INC. LITTLE ROCK, U.S.A.		BY DWN/PAW/LS	DATE 2-16-80	APPROVED BY E ENGR	DATE
MATERIAL	MODEL NO. 1022	CHK	MFG ENGR	TITLE 1022 KEYBOARD	
FINISH	TOL EX AS NOTED XX ± FRAC ± XXX ± ANG ± FINISH	SEE CHART	SIZE D	7596	4
SCALE	SHT 7 OF 8	WANG PART NUMBER	SIZE	CP WING NUMBER	BY

D 7596

THIS DRAWING AND THE DATA SHOWN THERE ON ARE THE CONFIDENTIAL PROPERTY OF, AND ARE PROPRIETARY TO, WANG LABORATORIES, INC. THIS DRAWING AND THE DATA SHOWN THEREIN MAY NOT BE MADE PUBLIC WITHOUT THE WRITTEN CONSENT OF WANG LABORATORIES, INC. IF FOR ANY REASON THIS DRAWING IS PERMITTED BY WANG TO LEAVE THE PHYSICAL CUSTODY OF THE COMPANY, IT IS RETURNABLE UPON THE DEMAND OF WANG LABORATORIES, INC.

COMPONENT	TYPE	W.L. PART NO.
R1	470Ω, 1/4W, 10%	330-2047
LED 1-4	LED SØ	370-0031
LED 7,8,10,11,12,15	LED R&D	370-0020
SW 1	5POS DIL SPST	325-1501
SW 4-8	118M1 MICRO	325-2305
CONN 1	26 PIN 90DEG	330-0058
TEST LED	STANDOFF	462-0515-1A

MNEMONICS	COORD.
CIRSW	(1B3)
CRLF	(1C10)
ERØ, ER3	(1E3)
ER1, ER2	(1F3)
FF	(1C3)
FLOUT	(1D3)
FMULT	(1E3)
FDR	(1C3)
LF	(1B3)
FLOUT	(1F3)
SLLT	(1D3)
SERVO	(1E10)
SLT1, SLT2	(1C3)
TSTSWØ	(1E10)
TSTSW1, TSTSW2	(1D10)
TSTTB	(1D10)
DLTOF	(1C3)

LOADING CHART

PART NO.	SW	LED	RES	CONN
7596	1, 4-8	1-4, 7, 8, 10, 11, 12, 15	R1	CONN 1
7596-1	1, 4, 6, 7	1-4, 7, 10, 11, 12, 15	R1	CONN 1

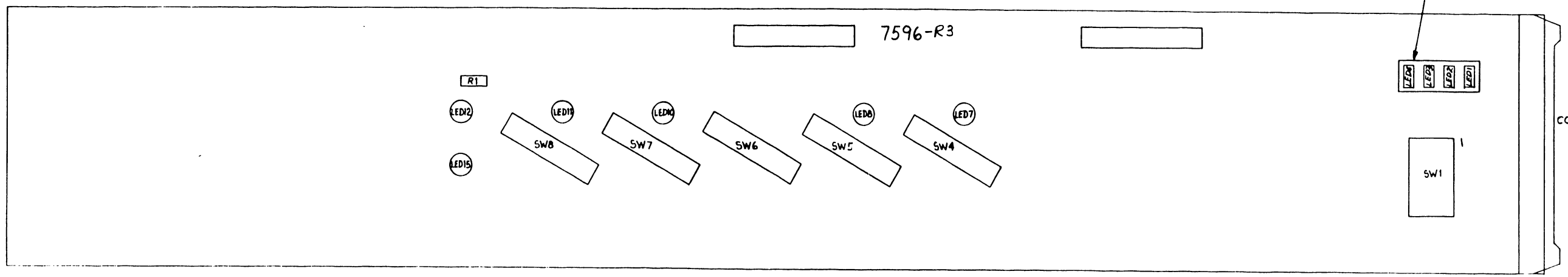
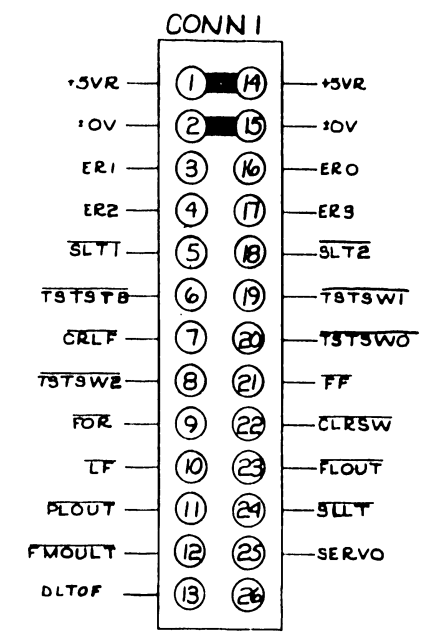

NO.	REVISION	DATE	BY	CHKD.	APP'D.
1	REV. 1.0	10-18-62	JEP		
2	REV. 2.0	10-18-62	T.K.		
3	REVISED PER ECO # 1775	10-22-62	JEP		
4	REVISED PER ECO # 1775	10-22-62	JEP		

WANG LABORATORIES, INC. LONDON, ENGLAND U.S.A.		BY	DATE	APPROVED BY	DATE
MATERIAL		DWN	7-24-62	E ENGR	
MODEL NO 1022		CHKD.		M ENGR	
SEE ENGR SPECIFICATIONS		TITLE 1022 KEYBOARD			
FINISH		SEE CHART		D	7596
TOL IS AS NOTED		SCALE		1/2" = 1"	4
MFG PART NUMBER		SIZE		DRAWING NUMBER	

THIS DRAWING AND THE DATA THEREON ARE THE PROPERTY OF WANG AND SHOULD BE KEPT IN STRICTLY CONFIDENTIAL. THE DATA HEREON IS TO BE USED ONLY FOR THE PURPOSES SPECIFIED BY THE ORIGINAL DRAWING. ANY REPRODUCTION OR TRANSMISSION OF THIS DRAWING IS PROHIBITED WITHOUT THE WRITTEN PERMISSION OF WANG. THE COMPANY IS NOT RESPONSIBLE FOR THE RESULTS OF THE USE OF THIS DRAWING IN ANY MANNER OTHER THAN THAT SPECIFIED BY THE ORIGINAL DRAWING.

DO NOT SCALE

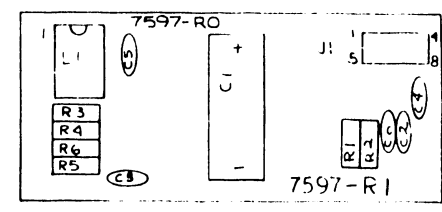
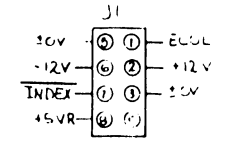

COMPONENT	TYPE	W.L. NO.
R1	330Ω 1/2W 5%	331-2034-4B
R2	4.7K 1/4W 10%	330-3097-4B
R3,4	6.8K 1/4W 10%	330-3068-4B
R5	470K 1/4W 10%	330-5097-4B
R6	1K 1/4W 10%	330-4097-4B
C1	47μF 15V	300-4020(T)
C2,4,6	1μF 50V(M.F.)	300-1931(C)
C3	.1μF 12V	300-4010(C)
C5	.001μF	300-1906(C)
J1	6 PIN HEADER	350-C212

LOCATION	TYPE	W.L. NO.
L1	LM311	376-C474

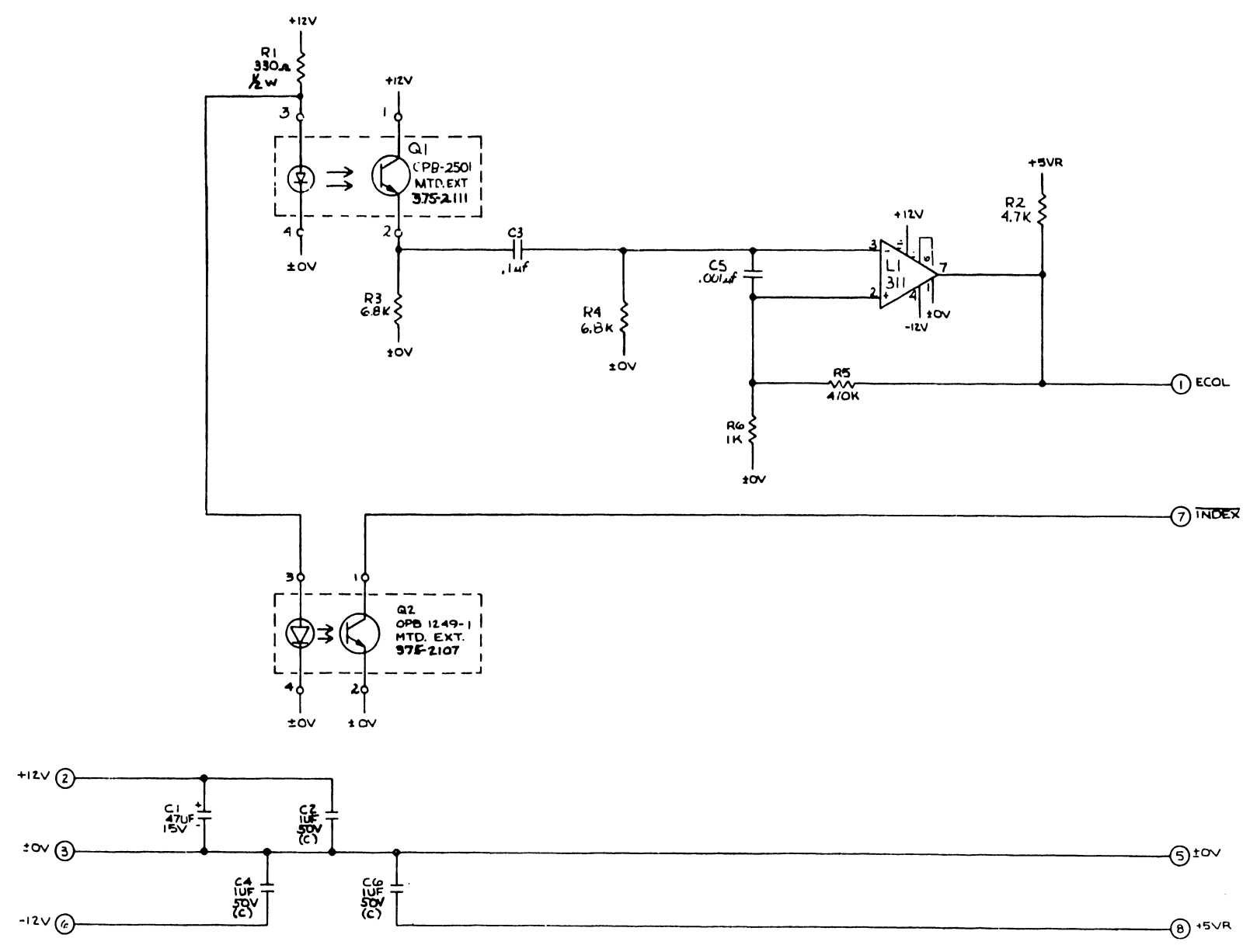

E-REV
0

NO.	REVISED FOR	DATE	BY
1	ORIGINAL	10/27/70	WJ
2	REVISED FOR	11/10/70	WJ
3	REVISED FOR	11/10/70	WJ
4	REVISED FOR	11/10/70	WJ
5	REVISED FOR	11/10/70	WJ
6	REVISED FOR	11/10/70	WJ
7	REVISED FOR	11/10/70	WJ

WANG LABORATORIES, INC. LITTLE ROCK, ARK. U.S.A.		BY	DATE	APPROVED BY	DATE
MATERIAL		DWN	11/10/70	E. ENGR. THOMAS L. J.	11/10/70
FINISH		CHE	11/10/70	M. ENGR.	
MODEL NO. 1022 SEE ENGR. SPECIFICATIONS		TITLE ENCODER AMPLIFILR			
TOL. EX. AS NOTED ±% ± FRACT. ± FINISH ±		210-7597	D	7597	2
SCALE: --+-- INT / OF /		WANG PART NUMBER	SIZE	DRAWING NUMBER	REV.

THIS DRAWING AND THE DATA SHOWN THERE ON ARE THE CONFIDENTIAL PROPERTY OF, AND ARE PROPRIETARY TO, WANG LABORATORIES, INC. THIS DRAWING AND THE DATA SHOWN THEREON MAY NOT BE MADE PUBLIC WITHOUT THE WRITTEN CONSENT OF WANG LABORATORIES, INC. IF FOR ANY REASON THIS DRAWING IS PERMITTED BY WANG TO LEAVE THE PHYSICAL CUSTODY OF THE COMPANY, IT IS RETURNABLE UPON THE DEMAND OF WANG LABORATORIES, INC.

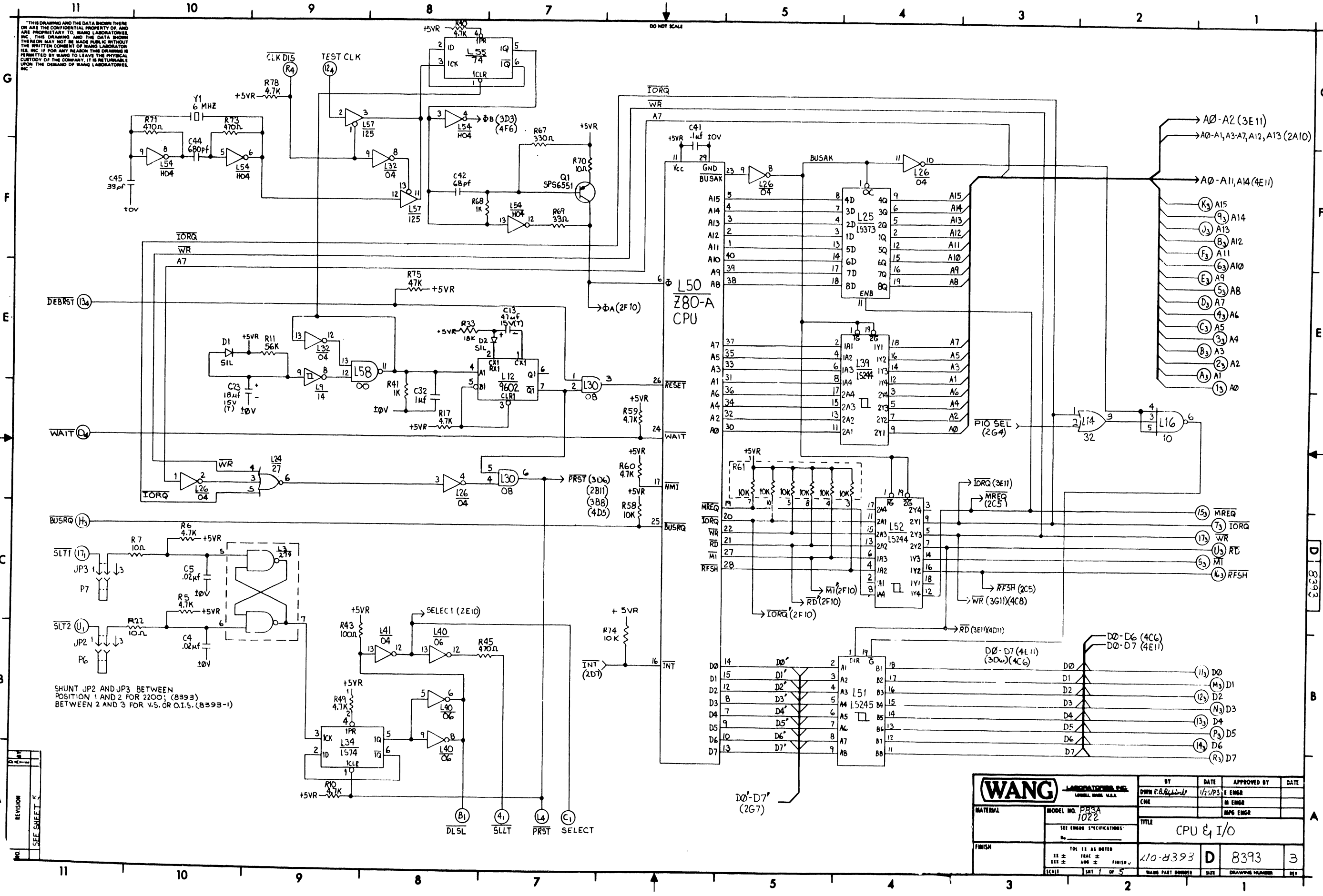

DO NOT SCALE

SHUNT JP2 AND JP3 BETWEEN POSITION 1 AND 2 FOR 220V; (8393) BETWEEN 2 AND 3 FOR V.S. OR O.I.S. (8393-1)

WANG LABORATORIES, INC. LOWELL, MASS. U.S.A.		BY DWM R.B. [Signature]	DATE 1/15/73	APPROVED BY E ENGR	DATE
MATERIAL	MODEL NO. P83A 1022	SEE ENGR SPECIFICATIONS	TITLE CPU & I/O		
FINISH	TOL. AS NOTED	SCALE 1/16" = 1"	110-8393	D	8393
			WANG PART NUMBER	SIZE	DRAWING NUMBER

NO.	REVISION	DATE	BY
	SEE SHEET 5		

"THE DRAWING AND THE DATA SHOWN THERE ON ARE THE CONFIDENTIAL PROPERTY OF, AND ARE PROPRIETARY TO, WANG LABORATORIES, INC. THIS DRAWING AND THE DATA SHOWN THEREIN MAY NOT BE MADE PUBLIC WITHOUT THE WRITTEN CONSENT OF WANG LABORATORIES, INC. IF FOR ANY REASON THIS DRAWING IS PERMITTED BY WANG TO LEAVE THE PHYSICAL CUSTODY OF THE COMPANY, IT IS RETURNABLE UPON THE DEMAND OF WANG LABORATORIES, INC."

DO NOT SCALE

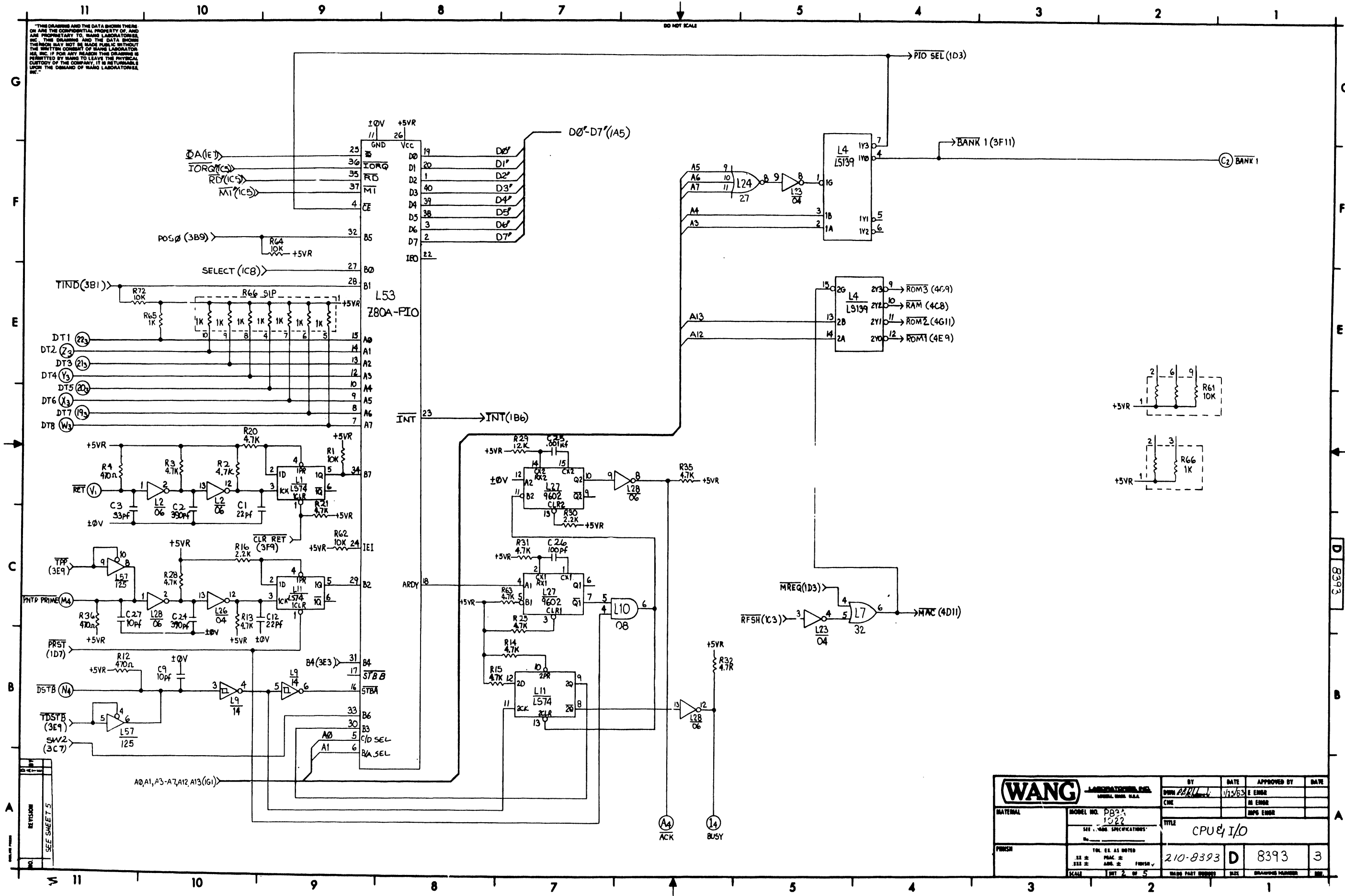

WANG LABORATORIES, INC. MODEL NO. 720		BY DWN/BR/1/1	DATE 1/15/83	APPROVED BY E ENDR	DATE
MATERIAL	MODEL NO. 720 1022	CHE		IN ENDR	
	SEE ADD. SPECIFICATIONS			MPG ENDR	
		TITLE CPU & I/O			
FINISH	TOL. EX. AS NOTED	210-8393	D	8393	3
	SCALE INT 2 OF 5	WANG PART NUMBER	SIZE	DRAWING NUMBER	REV.

REVISION
SEE SHEET 5

THIS DRAWING AND THE DATA SHOWN THEREIN ARE THE CONFIDENTIAL PROPERTY OF AND ARE PROPRIETARY TO WANG LABORATORIES, INC. THE COMPANY AND THE DATA SHOWN THEREON MAY NOT BE MADE PUBLIC WITHOUT THE WRITTEN CONSENT OF WANG LABORATORIES, INC. IF FOR ANY REASON THIS DRAWING IS FORWARDED BY WANG TO LEAVE THE PHYSICAL CUSTODY OF THE COMPANY, IT IS RETURNABLE UPON THE DEMAND OF WANG LABORATORIES, INC.

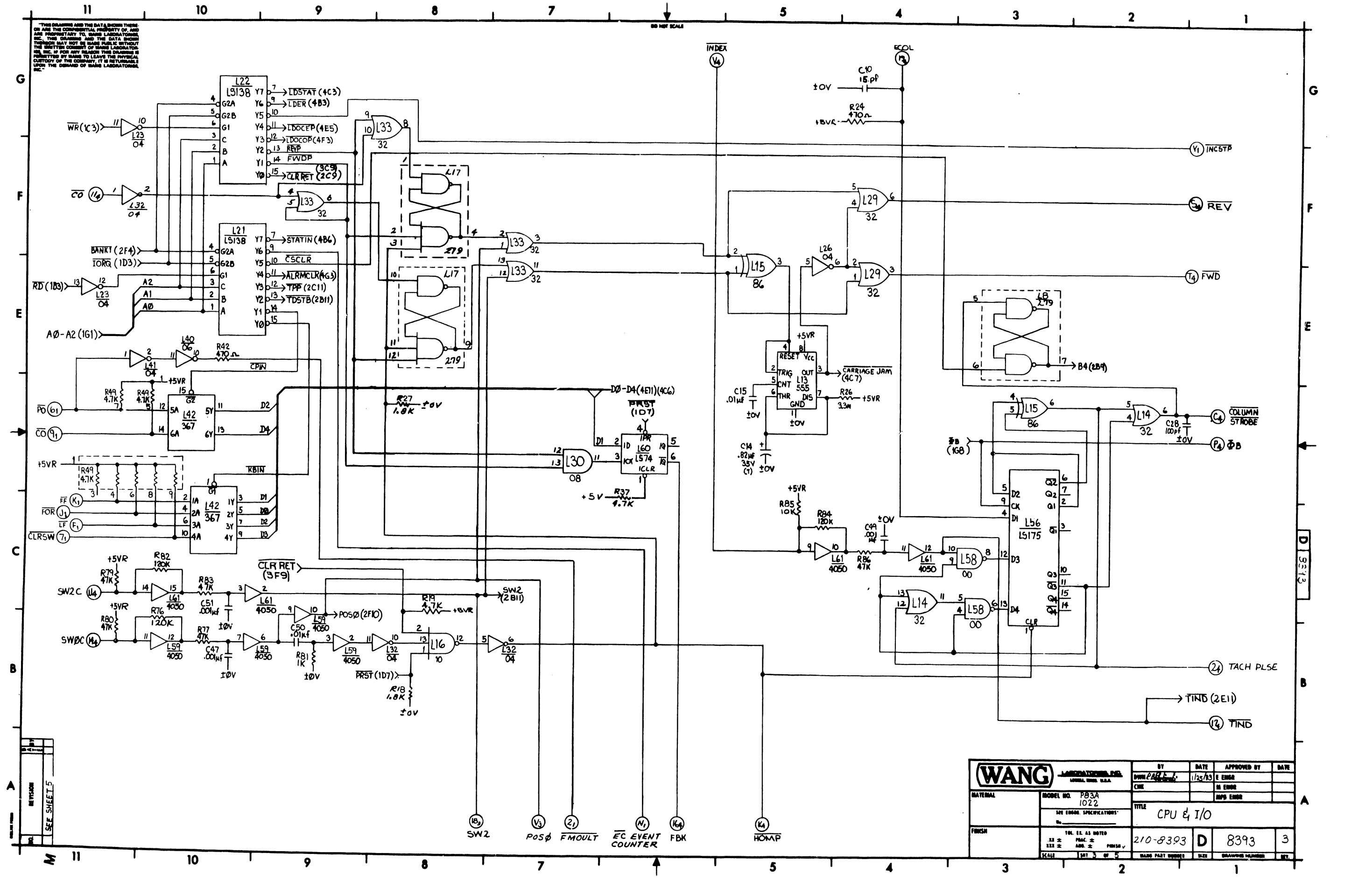

WANG LABORATORIES, INC. MODEL NO. PB3A 1022 SEE ENGR. SPECIFICATIONS		BY	DATE	APPROVED BY	DATE
		CHK	1/25/63	E ENGR	
TITLE		CPU & I/O			
PART NO.		210-8393	D	8393	3
SCALE		1/1	1/1	1/1	1/1

REVISION
SEE SHEET 5

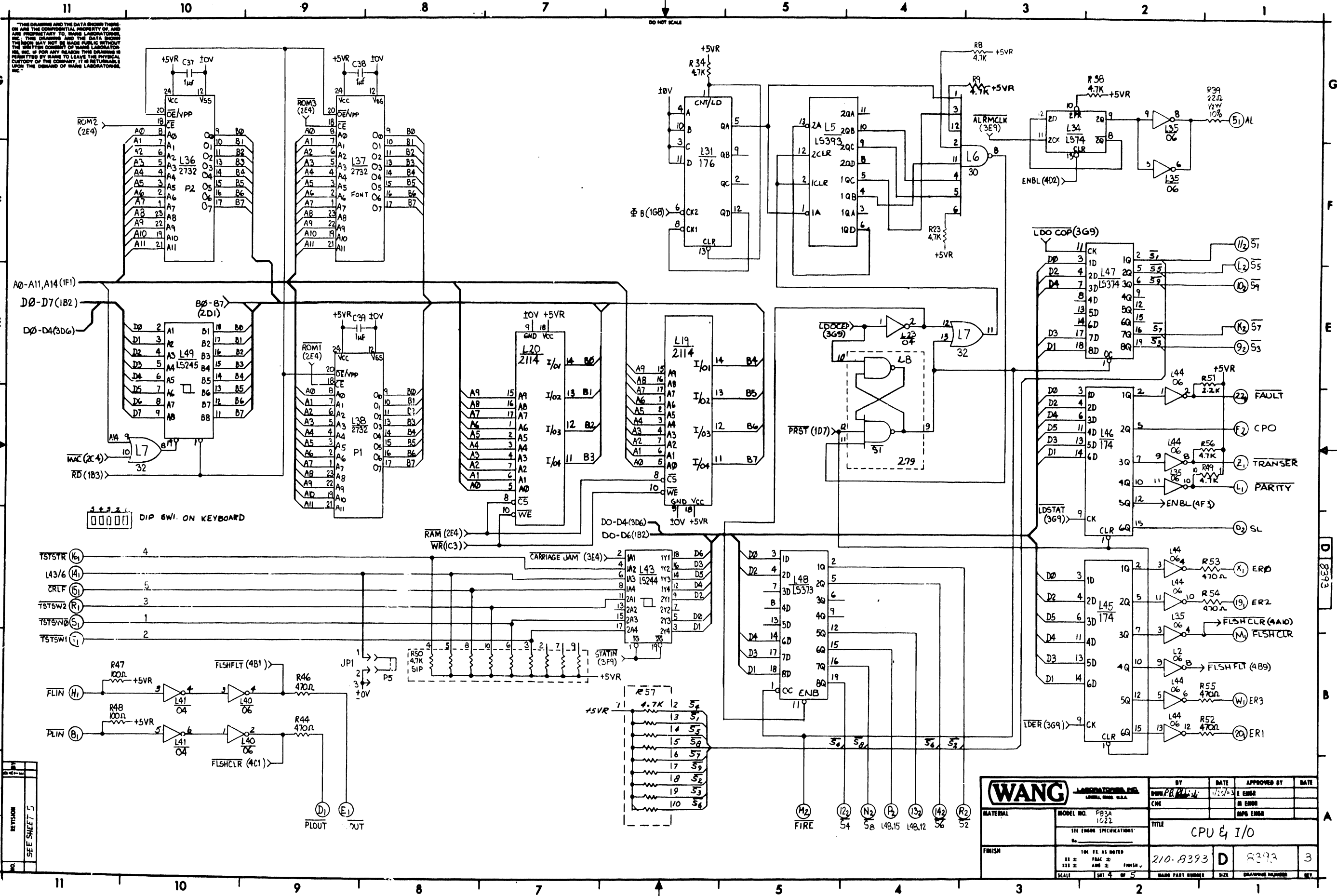

THIS DRAWING AND THE DATA SHOWN THEREON ARE THE CONFIDENTIAL PROPERTY OF AND ARE PROPRIETARY TO BANG LABORATORIES, INC. THIS DRAWING AND THE DATA SHOWN THEREON MAY NOT BE MADE PUBLIC WITHOUT THE WRITTEN CONSENT OF BANG LABORATORIES, INC. IN ANY CASE, THIS DRAWING IS LOANED TO YOU BY BANG LABORATORIES, INC. AND IS TO BE RETURNED TO BANG LABORATORIES, INC. UPON THE DEMAND OF BANG LABORATORIES, INC.

REV.	DESCRIPTION
1	ISSUED
2	REVISED
3	REVISED
4	REVISED
5	REVISED

WANG LABORATORIES, INC. LORDSBURG, N.M.		BY: P.B. [Signature]	DATE: 11/27/73	APPROVED BY: [Signature]	DATE:
MATERIAL:	MODEL NO. P83A 1022	CNK:		IN ENGR:	
SEE ENGR SPECIFICATIONS:		TITLE: CPU & I/O			
FINISH:	10% EE AS NOTED	210-8393	D	R393	3
NO.:	11 ± PAK ±	210-8393	D	R393	3
SCALE:	1:1 ±	1:1 ±	1:1 ±	1:1 ±	1:1 ±

THIS DRAWING AND THE DATA SHOWN THEREON ARE THE CONFIDENTIAL PROPERTY OF, AND ARE PROPRIETARY TO, WANG LABORATORIES, INC. THE DRAWING AND THE DATA SHOWN THEREON MAY NOT BE MADE PUBLIC WITHOUT THE WRITTEN CONSENT OF WANG LABORATORIES, INC. IF FOR ANY REASON THIS DRAWING IS PERMITTED BY WANG TO LEAVE THE PHYSICAL CUSTODY OF THE COMPANY, IT IS RETURNABLE UPON THE DEMAND OF WANG LABORATORIES, INC.

210 = 209 + 378 OR 377

	210	209	L37	L36	L38	L19	L20	L50	L53
8393-A	8393	377-0400	377-0400	377-0400	377-0341-L	377-0341-L	377-0368	377-0373	
8393-B	8393	378-6100							
8393-C	8393	378-6101							
8393-D	8393	378-6102							
8393-E	8393	378-6103							
8393-F	8393	378-6104							
8393-G	8393	378-6105							
8393-H	8393	378-6106							
8393-J	8393	378-6107							
8393-K	8393	378-6108							
8393-L	8393	378-6109							
8393-M	8393	378-6110							
8393-N	8393	378-6111							
8393-P	8393	378-6112							
8393-Q	8393	378-6113							
8393-IA	8393	377-0400	377-0400	377-0400	377-0341-L	377-0341-L	377-0368	377-0373	
8393-IB	8393	378-6114							
8393-IC	8393	378-6115							
8393-ID	8393	378-6116							
8393-IE	8393	378-6117							
8393-R	8393	378-6100	378-7018	378-7017					

I.C. TYPE	LOCATION	SPARE
4050	L59	2
	L61	2
7400	L58	1
7404	L23	1
	L32	1
	L41	2
74H04	L54	2
7406	L10	3
	L30	1
7406	L2	3
	L28	3
	L35	2
7410	L16	1
7414	L9	3
7427	L24	1
7474	L1	1
	L55	1
7486	L15	2
	L3	3
74279	L8	2
	L17	2
7432	L7	1
	L14	1
9602	L29	2
	L12	1

MNEMONIC	COORD.
A0-A15	1E1
ACK	2A6
AL	4G1
BANK1	2F1
BUSREQ	1C11
BUSY	2A6
CLR DIS	1G9
CLR SW	3C11
CO	3F11
CO	3D11
COLUMN STROBE	3D1
CPO	4D1
CRIF	4C11
DD-D7	1B1
DEBUST	1E11
DL5L	1A8
DSTB	2B11
DTI-DTB	2E11
ECOL	3G4
EE EVEN COUNTER	3A6
ER0-ER3	4B1
FAULT	4D1
FBK	3A6
FF	3C11
FIRE	4A5
FLIN	4B11
FLOUT	4A9
FISPECTR	4C1
FMOULT	3A7
FOR	3C11
FWD	3E1
HOMP	3A5
INCSYD	3G1
INDEX	3G6
ISRG	1C1
QFB	3D1
TF	3C11
L43.6	4C11
L48.12	4A4
L48.15	4A4
MI	1C1
MREG	1C1
PARITY	4D1
PLIN	4B11
FLOUT	4A9
PNTR PRIME	2C11
PO	3D11
POS0	3A7
PRST	1A7

MNEMONIC	COORD.
RD	1C1
REV	2D1
REV	3F1
RFSH	1C1
52, 54, 56, 58	4A4
51, 53, 55, 57, 59	4E1
SLT	1A7
SELECT	1A7
SL	4C1
SLT1	1C11
SLT2	1B11
SW2	3A8
SW0C, SW2C	3B11
TACH PLSE	3B1
TEST CLK	1G9
TIND	3B1
TRANSFER	4D1
TSTSW0 - TSTSW2	4C11
TSTSTR	4C11
WAIT	1D11
WR	1C1

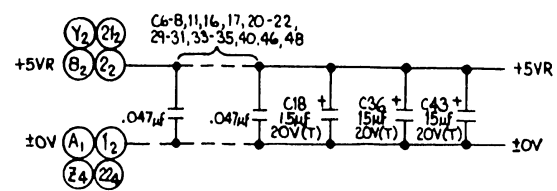

REV	BY	DATE	DESCRIPTION
1	DMR	1-25-83	ORIGINATED PER DMR
2	DMR	2-23-83	REVISED PER APP'D: DMC
3	DMR	7-1-83	REVISED PER ECO # 27060
4	DMR	7-1-83	REVISED PER ECO # 27870
5	DMR	7-1-83	REVISED PER ECO # 27519

WANG LABORATORIES, INC. LOCAL, BOSTON, U.S.A.		BY: DMR	DATE: 1/23/83	APPROVED BY: H. HUSSAIN	DATE: 2-23-83
MATERIAL:	MODEL NO. P83A 1022	CHK: DTC	DATE: 2-23-83	BY: HPG	ENGR:
SEE ENGR SPECIFICATIONS		TITLE: CPU & I/O			
FINISH:	TOL. AS NOTED	210-8393	D	8393	3
SCALE: 1/8" = 1"	SHEET 5 OF 5	MANUFACTURER:	SIZE:	DRAWING NUMBER:	BY:

END