

COMPAQ

MAINTENANCE & SERVICE GUIDE

COMPAQ DESKPRO 2000 SERIES
OF PERSONAL COMPUTERS



243211-001



243064-001



Notice

The information in this guide is subject to change without notice.

COMPAQ COMPUTER CORPORATION SHALL NOT BE LIABLE FOR TECHNICAL OR EDITORIAL ERRORS OR OMISSIONS CONTAINED HEREIN; NOR FOR INCIDENTAL OR CONSEQUENTIAL DAMAGES RESULTING FROM THE FURNISHING, PERFORMANCE, OR USE OF THIS MATERIAL.

This guide contains information protected by copyright. No part of this guide may be photocopied or reproduced in any form without prior written consent from Compaq Computer Corporation.

© 1996 Compaq Computer Corporation.
All rights reserved. Printed in the U.S.A.

Compaq, Deskpro
Registered U. S. Patent and Trademark Office.

Microsoft, MS-DOS, and Windows are registered trademarks of Microsoft Corporation.

The software described in this guide is furnished under a license agreement or nondisclosure agreement. The software may be used or copied only in accordance with the terms of the agreement.

Product names mentioned herein may be trademarks and/or registered trademarks of their respective companies.

Maintenance & Service Guide

Compaq Deskpro 2000 Series of Personal Computers

First Edition (September 1996)
Part Number 243064-001
Spare Part Number 243211-001

Compaq Computer Corporation

TABLE OF CONTENTS

preface

Symbols and Conventions	ix
Technician Notes	x
System Serial Number	x
Locating Additional Information	x

chapter 1

Product Description

1.1 Compaq Deskpro 2000 Series of Personal Computer Models	1-2
1.1.1 Desktop Models	1-2
1.1.2 Minitower Models.....	1-3
1.2 Features.....	1-4
Feature Summary	1-4
1.3 System Design	1-6
1.3.1 Design Overview	1-6
1.3.2 System Board.....	1-7
1.3.3 Processor.....	1-7
1.3.4 System Memory	1-7
1.3.5 Cache Memory.....	1-7
1.3.6 Graphics Controllers	1-8
1.3.7 IDE Peripheral Interface	1-8
1.3.8 System I/O	1-8
1.3.9 System BIOS.....	1-9
PCI Auto-Configuration.....	1-9
IDE Auto-Configuration	1-9
ISA Plug and Play Capability	1-9
BIOS Upgrades	1-9
1.3.10 Expansion Slots.....	1-9
1.3.11 Power Supply.....	1-9
1.3.12 Diskette Drive Interface.....	1-10
1.3.13 Serial Port	1-10
1.3.14 Parallel Port.....	1-10
1.3.15 System Security	1-10
1.3.16 Keyboard/Mouse Controller	1-10
1.3.17 Real-Time Clock and CMOS RAM.....	1-10
1.3.18 Power Supply Fan.....	1-10
1.3.19 Speaker	1-10
1.3.20 Software	1-11
Preloaded Software	1-11
Windows NT Workstation 3.51	1-11
1.3.21 Ordering Additional Operating System Drivers	1-11
1.3.22 Intelligent Manageability	1-12
AssetControl.....	1-12
Fault Management.....	1-13
1.3.23 Security Management	1-13

1.4 Desktop Computer Features	1-14
1.4.1 Front Panel Controls and LEDs	1-14
1.4.2 Drive Positions.....	1-15
1.4.3 Rear Panel Connectors.....	1-16
1.5 Minitower Computer Features.....	1-17
1.5.1 Front Panel Lights and Controls	1-18
1.5.2 Drive Positions.....	1-19
1.5.3 Rear Panel Connectors.....	1-21
1.6 SpaceSaver Keyboard.....	1-24
1.7 Options	1-28
1.7.1 Processor Upgrade	1-28
1.7.2 Mass Storage Options	1-28
1.7.3 Monitor Options.....	1-28
1.7.4 Graphics Controllers and Memory Options.....	1-29
1.7.5 Serial/Parallel Interface Board.....	1-29
1.7.6 Network Communications Options.....	1-29
1.7.7 Scanner Keyboard.....	1-29
1.7.8 PD-CD Drive	1-30
1.7.9 Modems	1-30
1.7.10 Software Options	1-30

chapter 2

Troubleshooting

2.1 Power-On Password	2-1
2.2 Power-On Self-Test (POST).....	2-3
2.2.1 Power-On Self-Test Messages.....	2-4
2.3 Compaq Configuration and Diagnostics.....	2-7
2.3.1 Preparing the Computer	2-8
2.3.2 Accessing the Configuration and Diagnostics Menu	2-8
Accessing the Configuration and Diagnostics Menu at Startup.....	2-8
Accessing the Configuration and Diagnostics Menu from Diskette	2-9
2.3.3 Using Configuration and Diagnostics Menu Options	2-10
Computer Checkup (TEST)	2-11
Running TEST	2-11
View System Information (INSPECT)	2-12
RemotePaq	2-13
Create a Diagnostics Diskette	2-13
Manage Diagnostics Partition	2-13
2.3.4 Compaq Diagnostics for Windows	2-14
2.4 Diagnostic Error Codes	2-15
2.4.1 SCSI Error Codes.....	2-23
2.5 Troubleshooting Without Diagnostics.....	2-26
2.5.1 Checklist for Solving Minor Problems	2-26
2.5.2 Power Problems	2-27
2.5.3 Diskette Drive Problems	2-28
2.5.4 Display Problems.....	2-29
2.5.5 Printer Problems	2-30
2.5.6 Hard Drive Problems	2-30
2.5.7 Hardware Installation Problems.....	2-32
2.5.8 CD-ROM Drive Problems	2-33
2.5.9 Memory Problems.....	2-34
2.5.10 SCSI Problems.....	2-35
2.5.11 Network Problems	2-36
2.5.12 Troubleshooting Using Compaq Intelligent Manageability Features	2-38

chapter 3

Illustrated Parts Catalog

3.1 System Unit	3-2
3.2 Mass Storage Devices.....	3-6
3.3 Cables	3-8
3.4 Standard and Optional Boards.....	3-10
3.5 Keyboards.....	3-13
3.6 Monitors	3-16
3.7 Miscellaneous Hardware Kit	3-19
3.8 Miscellaneous Plastics Kit.....	3-20
3.9 Miscellaneous Parts	3-22
3.10 Shipping Boxes.....	3-24
3.11 Documentation	3-25
3.12 Software.....	3-26

chapter 4

Removal and Replacement Preliminaries

4.1 Electrostatic Discharge Information	4-1
4.1.1 Generating Static.....	4-1
4.1.2 Preventing Electrostatic Damage to Equipment	4-2
4.1.3 Personal Grounding Methods	4-2
4.1.4 Grounding Workstations.....	4-3
4.1.5 Personal Grounding Equipment.....	4-3
4.1.6 Recommended Materials and Equipment	4-4
4.2 Service Considerations	4-4
4.2.1 Tools and Software Requirements	4-4
4.2.2 Screws.....	4-4
4.2.3 Cables and Connectors.....	4-5
4.2.4 Hard Drives.....	4-5
4.2.5 Plastic Parts.....	4-5
4.2.6 Lithium Battery.....	4-5

chapter 5

Removal and Replacement Procedures

5.1 Desktop Instructions	5-1
5.1.1 Serial Number	5-2
5.1.2 Disassembly/Assembly Sequence Chart.....	5-3
5.1.2.1 Desktop Computer - Pentium-Based System Board	5-3
5.1.2.2 Desktop Computer - Pentium Pro Based System Board	5-4
5.1.3 Preparation for Disassembly	5-5
5.1.4 Feet	5-6
5.1.5 Cable Lock.....	5-7
5.1.6 System Unit Cover.....	5-8
5.1.7 Speaker	5-9
5.1.8 Expansion Board.....	5-11
5.1.8.1 Inboard Expansion Board.....	5-12
5.1.8.2 Outboard Expansion Board	5-15
5.1.9 Replacement Battery	5-16
5.1.10 System Board Components.....	5-19
5.1.10.1 Memory Modules	5-19
5.1.10.2 Microprocessor.....	5-23
5.1.10.3 Cache Memory	5-26
5.1.10.4 PCI Performance Graphics Controller Memory Module Upgrade	5-27

5.1.11 Expansion Board Components.....	5-28
5.1.11.1 Matrox MGA Millennium Graphics Controller	5-28
5.1.11.2 Cirrus Logic 5446 Graphics Controller.....	5-29
5.1.12 Riser Board	5-30
5.1.13 Riser Brace.....	5-31
5.1.14 System Board.....	5-32
5.1.15 Front Bezel Assembly.....	5-34
5.1.15.1 Front Bezel.....	5-34
5.1.15.2 Power Button.....	5-34
5.1.15.3 Bezel Blank.....	5-35
5.1.16 Compaq Logo	5-37
5.1.17 Power Supply.....	5-38
5.1.18 Mass Storage Devices.....	5-41
Drive Positions.....	5-41
Adding an Additional Drive.....	5-41
5.1.18.1 3.5-Inch Wide Drive Bays.....	5-42
5.1.18.2 5.25-Inch Wide Drive Bays.....	5-45
5.1.18.3 Installing a New Drive	5-49
5.1.19 Expansion Board Guide	5-55
5.1.20 Drive Cage	5-56
5.1.21 LED Cable	5-57
5.2 Minitower Instructions	5-59
5.2.1 Serial Number	5-59
5.2.2 Disassembly/Assembly Sequence Chart.....	5-60
5.2.3 Preparation for Disassembly	5-61
5.2.4 Feet	5-62
5.2.5 Cable Lock.....	5-63
5.2.6 Exposing the Chassis	5-64
5.2.6.1 Access panel.....	5-64
5.2.6.2 Minitower “J” Hood.....	5-66
5.2.7 Riser Brace.....	5-67
5.2.8 Expansion Board.....	5-68
5.2.9 Expansion Board Guide	5-70
5.2.10 Expansion Board Components.....	5-71
5.2.10.1 Matrox MGA Millennium Graphics Controller	5-71
5.2.10.2 Cirrus Logic 5446 Graphics Controller.....	5-72
5.2.11 Riser Board	5-74
5.2.12 Replacement Battery.....	5-75
5.2.13 System Board Components.....	5-78
5.2.13.1 Memory Modules	5-78
5.2.13.2 Microprocessor.....	5-82
5.2.13.3 Cache Memory	5-85
5.2.13.4 PCI Performance Graphics Controller Memory Module Upgrade	5-86
5.2.14 System Board.....	5-87
5.2.15 Speaker	5-89
5.2.16 ISA Option Board Retainer.....	5-90
5.2.17 Front Bezel Assembly.....	5-91
5.2.17.1 Front Bezel.....	5-91
5.2.17.2 Power Button.....	5-92
5.2.17.3 Bezel Blank.....	5-93
5.2.18 Compaq Logo	5-94
5.2.19 Power Supply.....	5-95
5.2.20 Mass Storage Devices.....	5-98
Drive Positions.....	5-98

Adding an Additional Drive.....	5-99
5.2.20.1 3.5-Inch Wide Drive Bays.....	5-99
5.2.20.2 5.25-Inch Wide Drive Bays.....	5-102
5.2.20.3 Installing a New Drive	5-106
5.2.21 LED Cable	5-112

chapter 6

Jumper and Switch Information

6.1 System Board Switches	6-1
6.1.1 Pentium-Based System Board.....	6-1
6.1.2 Pentium Pro-Based System Board.....	6-2
6.1.3 Switch Settings	6-3
6.2 System Board Jumpers	6-4
6.2.1 Jumper Locations.....	6-4
Pentium-Based System Board.....	6-4
Pentium-Pro Based System Board	6-5
6.2.2 Setting Power-On Password Jumpers	6-5
6.2.3 Clearing Configuration	6-6
6.2.4 Changing the Real-Time Clock (RTC) Battery	6-6
6.3 Hard Drives	6-7
6.3.1 630-MB IDE Hard Drive Jumper Settings.....	6-7
6.3.2 1.08-GB IDE Hard Drive Jumper Settings	6-9
6.3.3 1.2-GB IDE Hard Drive Jumper Settings	6-11
6.3.4 1.62-GB IDE Hard Drive Jumper Settings	6-13
6.3.5 2.0-GB IDE Hard Drive Jumper Settings	6-14
6.3.6 2.5-GB IDE Hard Drive Jumper Settings	6-15
6.3.7 1.0-GB SCSI Hard Drive Jumper Settings	6-16
6.3.8 2.1-GB Ultra SCSI Hard Drive Jumper Settings	6-17
6.4 CD-ROM Drive Jumper Settings	6-18
6.5 PD-CD Drive Jumper Settings	6-18

chapter 7

Compaq Utilities

7.1 Configuring Windows Display and Monitor	7-1
Supported Resolutions	7-1
7.1.1 Changing Monitor Type Manually in Windows 3.1 and Windows NT	7-2
PCI Performance Graphics Controller	7-2
Matrox MGA Millennium Graphics Controller	7-2
Monitor Tab	7-2
Configuration Tab	7-2
Information Tab	7-3
About Tab	7-3
7.1.2 Changing Monitor Type Manually in Windows 95.....	7-4
PCI Performance Graphics Controller	7-4
7.1.3 Setting Graphics Resolution	7-4
PCI Performance Graphics Controller - Windows 95.....	7-4
PCI Performance Graphics Controller - Windows 3.1.....	7-4
Matrox MGA Millennium Graphics Controller - Windows 3.1	7-5
Matrox MGA Millennium Graphics Controller - Windows 95	7-5
7.1.4 Ordering Operating System Device Drivers	7-5
7.2 Power Management Utility.....	7-6
7.2.1 Power Management Features.....	7-6
7.2.2 Setting Power Management Values in Windows 3.1.....	7-6
7.2.3 Setting Power Management Values in Windows 95.....	7-7

7.2.4 Setting Power Management with Other Operating Systems.....	7-7
7.3 Security Management.....	7-8
7.3.1 Security Features.....	7-9
7.3.2 Establishing a Password in Windows 95.....	7-10
7.3.3 Establishing a Password in Windows NT.....	7-10
7.3.4 Establishing a Power-On Password Using Computer Setup.....	7-10
7.3.5 Entering a Power-On Password.....	7-10
7.3.6 Changing a Power-On Password.....	7-11
7.3.7 Deleting a Power-On Password.....	7-11
7.3.8 National Keyboard Delimiter Characters.....	7-12
7.4 Advanced Security Management.....	7-13
7.4.1 QuickLock/QuickBlank.....	7-13
Enabling QuickLock/QuickBlank.....	7-13
7.4.2 Keyboard and Mouse Interface.....	7-15
Disabling the Keyboard and Mouse Interface.....	7-15
Enabling the Keyboard and Mouse Interface.....	7-15
7.5 Flash ROM.....	7-16
7.6 Intelligent Manageability.....	7-17
7.6.1 Asset Management.....	7-18
7.6.2 Fault Management.....	7-18
7.6.3 Compaq Insight Personal Edition.....	7-19
7.6.4 Compaq Insight Manager.....	7-19
7.6.5 Changing the Default Configuration.....	7-19

chapter 8

Specifications

8.1 System.....	8-1
8.2 Drives.....	8-6
8.3 Mouse.....	8-11
8.4 Supported Graphics Resolutions.....	8-12

appendix A

Connector Pin Assignments	A-1
--	-----

appendix B

Power Cord Set Requirements

General Requirements.....	B-1
Country-Specific Requirements.....	B-2

appendix C

Hard Drives

Device 0/Device 1 Relationship.....	C-1
Cable Select.....	C-1
IntelliSafe - SMART.....	C-2
Automatic Soft-Drive Types.....	C-2

preface

This *Maintenance & Service Guide* is a troubleshooting guide that can be used for reference when servicing the the Compaq Deskpro 2000 Series of Personal Computers.

Compaq Computer Corporation reserves the right to make changes to the Compaq Deskpro 2000 Series of Personal Computers without notice.

Symbols and Conventions

The following words and symbols mark special messages throughout this guide:



WARNING: Text set off in this manner indicates that failure to follow directions in the warning could result in bodily harm or loss of life.



CAUTION: Text set off in this manner indicates that failure to follow directions could result in damage to equipment or loss of data.



Text set off in this manner presents clarifying information, specific instructions, commentary, sidelights, or other points of information.

The following format conventions distinguish elements of the text throughout this guide:

- Drive letters that are not in command lines are presented in uppercase type as shown here: drive A.
- Directory names that are not in command lines are presented in uppercase type as shown here: DIRECTORY.
- The file names are presented in uppercase italic type as shown here: *FILENAME*.
- The names of commands are presented in lowercase as shown here: install, or a:\install.
- Commands that are to be entered at the system prompt may be shown on a separate line.
- When you need to type information without pressing **Enter**, you are directed to "type" the information.
- When you need to type information *and* press **Enter**, you are directed to "enter" the information.

Technician Notes



WARNING: Only authorized technicians trained by Compaq should attempt to repair this equipment. All troubleshooting and repair procedures are detailed to allow only subassembly/module-level repair. Because of the complexity of the individual boards and subassemblies, no one should attempt to make repairs at the component level or to make modifications to any printed wiring board. Improper repairs can create a safety hazard. Any indication of component replacement or printed wiring board modifications may void any warranty or exchange allowances.



CAUTION: To properly ventilate the computer system, you must provide at least 3 inches (7.62 cm) of clearance on the front and back of the computer.



WARNING: The computer is designed to be electrically grounded. To ensure proper operation, plug the AC power cord into a properly grounded electrical outlet only.

System Serial Number

The serial number is displayed on the right-hand side of the computer, near the front, and near the I/O ports on the rear of the computer.

For the purpose of AssetControl, the serial number is embedded in the CMOS on the system board.

Locating Additional Information

The following documentation is available to support the computer:

- *Compaq Reference Guide*
- *Compaq Dictionary* (online document)
- *Compaq Quick Setup* card
- *Compaq QuickFind*, a subscription reference service
- *Compaq Safety & Comfort Guide*
- Compaq Service Advisories and Bulletins
- *Compaq Service Quick Reference Guide*
- *Compaq Technical Reference Guide*
- *Illustrated Parts Map* (poster)
- Technical Training Guides

chapter 1

PRODUCT DESCRIPTION

This chapter describes the model offerings and features of the Compaq Deskpro 2000 Series of Personal Computers.



Figure 1-1. Compaq Deskpro 2000 Series Personal Computer

1.1 Compaq Deskpro 2000 Series of Personal Computer Models

The Compaq Deskpro 2000 Series of Personal Computers are available in both Desktop and Minitower configurations described in the following sections.

1.1.1 Desktop Models

The desktop models are described in Table 1-1.

**Table 1-1
Desktop Models***

Configuration Code	Processor	Hard Drive	CD-ROM	Memory	Maximum Memory	Cache	Graphics
HVQ2	P5/100	630 MB	No	8-MB	128-MB	No	Cirrus Logic †
HVR3	P5/100	1.2 GB	No	8-MB	128-MB	No	Cirrus Logic †
HVR5	P5/100	1.2 GB	No	16-MB	128-MB	No	Cirrus Logic †
HVR6	P5/100	1.08 GB	No	16-MB	128-MB	No	Cirrus Logic †
HVR7	P5/100	1.08 GB	No	8-MB	128-MB	No	Cirrus Logic †
HVS3	P5/120	1.2 GB	No	8-MB	128-MB	256K	Cirrus Logic †
HVS4	P5/120	1.2 GB	No	16-MB	128-MB	256K	Cirrus Logic †
HVS5	P5/120	1.08 GB	No	8-MB	128-MB	256K	Cirrus Logic †
HVS6	P5/120	1.08 GB	No	16-MB	128-MB	256K	Cirrus Logic †
HVT3	P5/133	1.2 GB	No	16-MB	128-MB	256K	Cirrus Logic †
HVT5	P5/133	2.5 GB	No	16-MB	128-MB	256K	Cirrus Logic †
HVT7	P5/133	1.08 GB	No	16-MB	128-MB	256K	Cirrus Logic †
HVT8	P5/133	1.62 GB	No	16-MB	128-MB	256K	Cirrus Logic †
HVU5	P5/166	1.2 GB	No	16-MB	128-MB	256K	Cirrus Logic †
HVU6	P5/166	2.5 GB	No	16-MB	128-MB	256K	Cirrus Logic †
HVU7	P5/166	1.08 GB	No	16-MB	128-MB	256K	Cirrus Logic †
HVU8	P5/166	1.62 GB	No	16-MB	128-MB	256K	Cirrus Logic †
HWC2	P5/200	2.5 GB	No	32-MB	128-MB	256K	Cirrus Logic †
HWC3	P5/200	1.62 GB	No	32-MB	128-MB	256K	Cirrus Logic †
HVW2	P6/180	1.2 GB	Yes	16-MB	192-MB	Internal	Cirrus Logic ††
HVW3	P6/180	1.08 GB	Yes	16-MB	192-MB	Internal	Cirrus Logic ††
HVV6	P6/200	2.5 GB	Yes	16-MB	192-MB	Internal	Matrox**
HVV7	P6/200	1.62 GB	Yes	16-MB	192-MB	Internal	Matrox**

*Not all models are available in all geographic regions.

**Matrox MGA Millennium Graphics

† Cirrus Logic 5436

†† Cirrus Logic 5446

1.1.2 Minitower Models

The minitower models are described in Table 1-2.

Configuration Code	Processor	Hard Drive	CD-ROM	Memory	Maximum Memory	Cache	Graphics
HVX6	P5/133	2.5 GB	Yes	16-MB	128-MB	256K	Cirrus Logic †
HVX7	P5/133	1.62 GB	Yes	16-MB	128-MB	256K	Cirrus Logic †
HVY6	P5/166	2.5 GB	Yes	32-MB	128-MB	256K	Cirrus Logic †
HVY7	P5/166	1.62 GB	Yes	32-MB	128-MB	256K	Cirrus Logic †
HVZ6	P6/200	2.5 GB	Yes	32-MB	192-MB	Integrated	Matrox**
HVZ7	P6/200	1.62 GB	Yes	32-MB	192-MB	Integrated	Matrox**

*Not all models are available in all geographic regions.

**Matrox MGA Millennium Graphics

†Cirrus Logic 5436

1.2 Features

Feature Summary

The Compaq Deskpro 2000 Series of Personal Computers have the following standard features:

- Pentium processors running at speeds ranging from 100 to 200 megahertz or a Pentium Pro processor with speeds of 180 to 200 megahertz
- 256-kilobyte secondary (L2) cache module on select Pentium models (optional on other models)
- 256-kilobyte secondary (L2) cache integrated into the processor chip on Pentium Pro models
- Peripheral Components Interconnect (PCI) chipset used for PCI/ISA, memory, and peripheral control
- Super I/O controller (integrates a serial port, parallel port, diskette drive interface, real-time clock, CMOS RAM, and mouse and keyboard controller)
- PCI and ISA peripheral connectors on the expansion riser board
- 8-, 16-, and 32-megabyte extended data out (EDO) dynamic random access memory (DRAM) standard; expandable to 128 or 192 megabytes of DRAM installed in single inline memory modules (SIMMs)
- BIOS in a flash memory device supports PCI auto-configuration
- Desktop chassis includes expansion slots for up to five expansion boards
 - Two dedicated PCI slots (one half-length and one full-length)
 - Two dedicated ISA-bus slots (one half-length and one full-length)
 - One "combination" slot for either a PCI or an ISA expansion board
- Minitower chassis includes expansion slots for up to five expansion boards
 - Two dedicated full-length PCI slots
 - Two dedicated ISA-bus slots (one half-length and one full-length)
 - One "combination" slot for either a PCI or an ISA expansion board
- 200-watt continuous power supply, switch-selectable for 115 and 230 VAC operation, is used for both desktop and minitower models
- One RS-232C-compatible 9-pin serial connector
- One multimode, 25-pin enhanced parallel connector
- One USB connector on Pentium Pro models

- Five drive bays on desktop models:
 - ❑ One external 3.5-inch, one-third height diskette drive bay
 - ❑ One internal 3.5-inch, one-third height drive bay
 - ❑ Two external 5.25-inch, one-half height drive bays (*or* one full-height drive)
 - ❑ One internal 5.25-inch hard drive bay (one-third height or 3.5-inch hard drive with a special bracket)
- Five drive bays on minitower models:
 - ❑ One external 3.5-inch, one-third height diskette drive bay
 - ❑ One internal 3.5-inch, one-third height drive bay
 - ❑ Three external 5.25-inch, one-half height drive bays (*or* one full-height drive)
- One enhanced IDE (EIDE) hard drive installed: hard drive sizes range from 630 megabytes to 2.5 gigabytes, depending on geographic location. 1.62 GB is the largest drive available in EMEA.
- ✍ The 2.5 gigabyte hard drive is partitioned into two, equally sized logical drives.
- Drive fault prediction on all hard drives
- One 1.44-megabyte, 3.5-inch high-density diskette drive installed
- One 8X IDE CD-ROM drive installed on select models
- 1- to 2-megabyte graphics controller installed, depending on the model
- Compaq SpaceSaver Keyboard, featuring the Microsoft Windows-specific keys
- Mouse
- Keyboard and mouse connectors on the back panel
- Internal piezo speaker mounted on system board
- Intelligent Manageability and security features, including password and cable lock provision
- Microsoft Windows 95, Microsoft Windows 3.1 and MS/DOS, Microsoft Windows NT Workstation 3.51, or Microsoft Windows NT Workstation 4.0 operating system software
- Compaq Diagnostics and Configuration utilities, support software, and device drivers

1.3 System Design

This section presents a design overview and functional descriptions of the key components of the Compaq Deskpro 2000 Series of Personal Computers. All replaceable components are identified in Chapter 3, and removal/replacement instructions are presented in Chapter 5.

1.3.1 Design Overview

The desktop models of the Compaq Deskpro 2000 Series of Personal Computers have a conventional design that uses a pan-type chassis to house the system board, expansion cards, power supply, and mass storage devices. The chassis is supplemented by a riser board attached to the riser brace. The riser board provides a mounting location for the expansion cards.

All internal components are accessible when the hood, held in place by two thumbscrews, is removed. The front bezel is mounted to the front of the chassis. Torx T-15 screws are used throughout the system except for the power supply switch mounting bracket, which uses T-10 screws.

The system board is easily removed from the side of the chassis after the hood and riser board are removed. Two mounting screws secure the riser board to the riser brace. Four mounting screws are used on the Pentium and five screws on the Pentium Pro to secure the system board to the chassis. In addition, the I/O bracket is mounted to the system board and is spared that way.

The riser board mounts perpendicular to the system board. Expansion boards are installed horizontally into the riser board. A single screw attaches each expansion board to the rear panel of the chassis.

The power supply is mounted in the right rear corner of the chassis. The power supply is held in place by five Torx screws, two mounted internally and three that are installed through the rear panel of the chassis.

The minitower models' chassis is designed to house the system board, riser board, option cards, power supply, and mass storage devices. The use of a riser brace to hold the riser board, and any expansion boards installed, allows for easy access to the system board. The power supply is mounted in the top of the unit.

All internal components are immediately accessible when the side panel, held in place with three thumbscrews, is removed. The front bezel is a separate assembly that mounts to the front of the chassis.

The tray-mounted system board is easily removed by taking off the side panel, removing the riser brace, and then pulling the tray assembly from the chassis. The system board is spared installed in the tray.

Detailed descriptions of the system components are presented in the sections that follow.

1.3.2 System Board

The desktop and minitower models of the Compaq Deskpro 2000 Series of Personal Computers use two basic system board configurations, either a Pentium- or a Pentium Pro-based board. The desktop units have the I/O panel mounted to the system board and are spared with the I/O panel attached. On the minitower, the system board is attached to a sliding tray and is spared with the tray.

1.3.3 Processor

The Pentium-based system boards run at processor speeds of 100MHz to 200MHz.

The Pentium Pro-based system boards run at processor speeds of 180MHz and 200MHz.

1.3.4 System Memory

The system supports base (conventional) and extended memory. Operating systems such as MS-DOS, OS/2, UNIX, and all application programs use base memory. For better performance, Windows NT, OS/2, and UNIX, as well as many MS-DOS applications, use extended memory.

The computers ship standard with 60-ns EDO tin-lead (SnPb) SIMMs installed and supports up to 128 megabytes of memory (Pentium models) or 192 megabytes of memory (Pentium Pro models). Either Extended Data Out (EDO) random access memory (RAM) or Fast Page Mode (FPM) dynamic random access memory (DRAM) modules may be used. If EDO and FPM modules are combined in the computer, they must be as matched pairs. For example, two identical EDO modules may be used with two identical FPM modules.

The SIMM sockets on all system boards in this series of computers can be populated with 4-, 8-, 16-, or 32-MB SIMMs in matched pairs. SIMM sockets on the system boards must be populated in pairs of equal size in sequential slots. The SIMMs for the system boards must be 60 ns or 70 ns. Refer to Chapter 5, "Removal and Replacement Procedures," for information on how to upgrade system memory.

The Pentium-based system boards accommodate a total of four SIMMs.

The Pentium Pro-based system boards accommodate a total of six SIMMs.

- ✎ SIMMs with tin-lead pins must be used for memory upgrades.
- ✎ System memory speed will be configured on a bank-by-bank basis allowing each bank to run at its optimum speed.

1.3.5 Cache Memory

Cache memory is very fast memory used for temporarily storing data for fast access by the processor. The faster the processor, the more need there is for temporary data storage. One 256-kilobyte write-back, direct mapped secondary (L2) cache module is installed on the Pentium system board. Cache is standard on models with a speed of 120 megahertz or higher. Cache is optional on lower speed processors. A 256-kilobyte write-back, four-way, set associative secondary (L2) cache is integrated into the processor on Pentium Pro models.

1.3.6 Graphics Controllers

The purpose of a graphics controller is to generate the text and graphics images for the monitor screen. The quality of the picture you see depends on the resolution of the monitor and the number of colors that can be displayed. High resolution graphics with many colors require that the graphics controller have its own memory system. The computer comes with one of three graphics controllers:

- The Cirrus Logic 5436 PCI performance graphics controller comes standard with 1 megabyte of EDO DRAM, which can be upgraded to 2 megabytes of EDO DRAM.
- The Cirrus Logic 5446 PCI performance graphics controller comes standard with 1 megabyte of EDO DRAM, which can be upgraded to 2 megabytes of EDO DRAM.
- The Matrox MGA Millennium graphics controller comes standard with 2 megabytes of Windows random access memory (WRAM), which can be upgraded to 4 or 8 megabytes of WRAM.

Supported screen resolutions for each of the above controllers are listed in Chapter 8, "Specifications".

1.3.7 IDE Peripheral Interface

The onboard PCI chipset provides a high-speed, 32-bit PCI/IDE interface, which supports the following:

- Up to four PCI/IDE hard drives on the PCI bus
- Enhanced Mode 3 and Mode 4 support
- Logical block addressing (LBA) of hard drives larger than 528 megabytes
- Extended cylinder head sector (ECHS) translation modes
- ATAPI devices (such as CD-ROMs) on both IDE interfaces

1.3.8 System I/O

The onboard I/O controller integrates the functions for the serial and parallel ports, diskette drives, and the keyboard. This component provides support for the following:

- Multimode bidirectional parallel port
 - Standard mode: Centronics-compatible operation
 - High-speed mode with support for an enhanced capabilities port (ECP) and enhanced parallel port (EPP)
- One RS-232C compatible 9-pin serial port
- One USB Connector (Pentium Pro models only)
- Integrated real-time clock
- A 242-byte, battery-backed CMOS RAM
- Integrated 8042-compatible keyboard controller
- Industry-standard diskette drive controller that supports:
 - 720-kilobyte and 1.44-megabyte 3.5-inch drives (at 135 tracks per inch)
 - 360-kilobyte and 1.2-megabyte 5.25-inch drives

1.3.9 System BIOS

The system BIOS provides ISA and PCI compatibility. Contained in a flash memory device on the system board, the BIOS provides the power-on self-test (POST) and the PCI and IDE auto-configuration utilities.

The system BIOS is always “shadowed.” Shadowing allows any BIOS routines to be executed from fast 32-bit onboard DRAM instead of from the slower 8-bit flash device.

PCI Auto-Configuration

The PCI auto-configuration utility works in conjunction with the Setup program to support using PCI expansion boards in the system. When you turn on the computer power after installing a PCI board, the BIOS automatically configures interrupts, I/O space, and PCI devices. If problems arise or you wish to reconfigure the device, refer to Chapter 7, “Compaq Utilities,” which explains how to use the Setup program. The PCI auto-configuration program complies with version 2.1 of the PCI BIOS specification.

IDE Auto-Configuration

If you install an IDE drive into the computer, the IDE auto-configuration utility automatically detects and configures the drive for operation in the computer. This utility eliminates the need to run the Setup program after you install an IDE drive.

ISA Plug and Play Capability

ISA Plug and Play capability provides auto-configuration of Plug and Play ISA boards and resource management for legacy (non Plug and Play) ISA boards when used with Compaq’s Computer Setup for Windows (CSW) utility (or **F10** Setup) or a Plug and Play-compatible operating system like Microsoft’s Windows 95.

BIOS Upgrades

Because the BIOS is stored in a flash memory device, you can easily upgrade the BIOS without having to disassemble the system. The flash upgrade process can be accomplished by running a utility from a diskette, a hard drive, or over a network.

The section on Flash ROM in Chapter 7, “Compaq Utilities,” explains how to run the BIOS upgrade utility. For information about the latest BIOS update, contact an authorized Compaq service provider.

1.3.10 Expansion Slots

The computer has two dedicated 16-bit ISA-compatible slots, two dedicated PCI-compatible expansion slots, and one “combination slot” that can be used by either a PCI or an ISA board. For more information about expansion slots and installing expansion boards, see Chapter 5, “Removal and Replacement Procedures.”

1.3.11 Power Supply

The desktop and the minitower computers share a 200-watt rated continuous power supply to provide power for onboard resources, expansion boards, and drives. A switch on the computer back panel sets the power supply to operate at:

- 115 VAC (in the range of 100-120 VAC; 5.0 A maximum input current)
- 230 VAC (in the range of 200-240 VAC; 3.0 A maximum input current)

For power supply output ratings, see Chapter 8, “Specifications.”

1.3.12 Diskette Drive Interface

The diskette drive interface is 8477 compatible and supports two storage devices (diskette or tape drive).

1.3.13 Serial Port

The serial port is RS-232C compatible.

1.3.14 Parallel Port

The following parallel support modes are supported:

- SPP (Bidirectional Standard Parallel Port)
- EPP (Enhanced Parallel Port)
- ECP (Extended Capabilities Port)

1.3.15 System Security

The system BIOS provides a power-on password option that is enabled through the Setup program. The computer includes a cable lock provision that makes it possible to lock the computer cover in place to prevent unauthorized access to the system jumpers and other internal components (a padlock is not included). For more information on this and additional security features, refer to Chapter 2, “Troubleshooting,” and Chapter 7, “Compaq Utilities.”

1.3.16 Keyboard/Mouse Controller

The onboard 8042 I/O controller stores the keyboard and mouse controller code. Connectors for the keyboard and mouse are located on the back panel.

1.3.17 Real-Time Clock and CMOS RAM

The onboard I/O controller provides a real-time clock and CMOS RAM. Chapter 5 provides information about installing a new battery.

You can set the time for the clock and the CMOS values by using the Setup program described in Chapter 7, “Compaq Utilities.”

1.3.18 Power Supply Fan

For cooling, a fan is attached to the power supply at the rear of the computer chassis. This fan draws air in through the front of the chassis and exhausts air out the rear of the chassis. This provides air flow across the processor.

1.3.19 Speaker

An internal piezo speaker is mounted on the system board. The speaker provides audible error code information (beep codes) during the power-on self-test (POST) and as required by the software. See Chapter 2, “Troubleshooting,” for beep code information.

1.3.20 Software

During initial Setup, the user is required to select the operating system to be installed. The following operating systems are shipped with the computer:

- Windows 95: Pentium-based computers only
- Windows 3.1 and MS/DOS: Pentium-based computers only
- Windows NT 3.51: Pentium Pro-based computers only

Preloaded Software

The following Compaq software is preloaded on the computer:

- Microsoft Windows 3.1 or Windows 95 installation, one of which the user is required to choose during initial setup. This is only available on Pentium-based computer models.
- Partition-based Compaq Diagnostics utilities
- Compaq Diagnostics for Windows
- Compaq support software and device drivers
- Online *Safety & Comfort Guide*
- Intelligent Manageability
- Power Management with Energy Saver features
- Security Management

Windows NT Workstation 3.51

The Windows NT 3.51 operating system software is provided on a compact disc (CD) with Pentium Pro-based computers for easy installation along with the following Compaq software:

- Compaq Diagnostics for Windows NT
- Compaq support software and device drivers
- Online *Safety & Comfort Guide*

1.3.21 Ordering Additional Operating System Drivers

If you plan to run any of the following operating systems on the computer, you must install the corresponding Compaq device drivers and utilities before attempting to use the computer:

- IBM OS/2 or NetWare
- Microsoft Windows NT Workstation 3.51 on computers that are not shipped with that operating system
- A version of Microsoft Windows 95 or Microsoft Windows NT Workstation that is different from the version included with the computer

There are two methods to order copies of suitable device drivers and utilities:

- Order the *Support Software CD for Compaq Desktop Products*. This compact disc contains the latest device drivers, utilities, and flashable ROM images needed to run MS-DOS, Windows 3.1, Windows 95, Windows NT Workstation 3.51, IBM OS/2, and NetWare on the Compaq commercial desktop product.
- Purchase backup diskettes.

The *Support Software CD* can be purchased in either of two ways:

- A single CD-ROM that gives one-time access to the latest support software (North America only).
- A yearly subscription that delivers up to 12 monthly CD-ROMs.

The annual subscription provides continuous access to the latest developments, while the single CD-ROM offers information as it is needed.

- ✍ When calling Compaq to place an order, be sure to have the serial number of the computer available. The serial number is located on the right-hand side of the computer cover and also on the rear of the chassis. This number is necessary for all purchases.

1.3.22 Intelligent Manageability

Intelligent Manageability includes:

- AssetControl
- Fault management
- Security management

AssetControl

AssetControl allows a system administrator to view, track, and store information about the desktop computer. This capability is available locally with the Diagnostics for Windows utility or remotely with third-party applications. The following information is provided:

- System serial number
- Asset tag
- Monitor serial number (with monitor support)
- Firmware revision levels
- System board revision level
- Name and version of Compaq-developed software

Fault Management

Fault management is available locally at power-on or through the Diagnostics for Windows utility. When this feature is used with the appropriate management software and operating system, system administrators and users can monitor the computer for impending component or subsystem failure. This includes:

- Hard drive fault prevention tracking
- Accurate contact information

1.3.23 Security Management

Security management features are designed into the Compaq Deskpro Personal Computer. The following features prevent unauthorized access to critical data and prevent theft of the computer:

- Cable lock provision allows the user to physically secure the computer hardware to protect against theft.
- Diskette boot control prevents the computer from being booted from a diskette.
- Diskette drive control allows disabling of the diskette drive.
- Diskette write control prevents unauthorized writing of data to a diskette.
- Flash ROM lock prevents unauthorized changes to the flash ROM.
- Keyboard password allows the computer to boot up but prevents data input until the password is entered.
- Parallel interface control prevents transfer of data through the parallel interface connector.
- Power-on password prevents unauthorized persons from booting up the computer.
- QuickLock/QuickBlank allows the user to lock the keyboard and/or blank the screen.
- Serial interface control prevents transfer of data through the serial interface connector.
- Setup Password prevents unauthorized changes to the system configuration.

1.4 Desktop Computer Features

The Compaq Deskpro 2000 Series of Personal Computers ships with a mouse and keyboard. A Compaq color monitor or other compatible monitor, which is also required to operate the computer, does not ship with the computer.

1.4.1 Front Panel Controls and LEDs

The operator controls and LEDs located on the front panel of the computer are identified and described below.

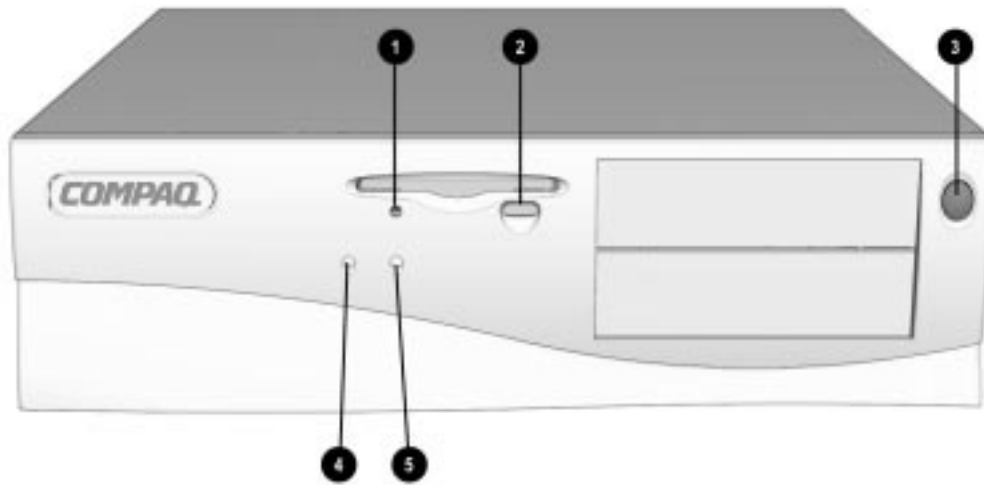


Figure 1-2. Power Switch and Front Panel Lights

Table 1-3
Lights and Controls

Ref.	Component	Function
❶	Diskette Drive Activity Light	Turns on when the diskette drive is reading or writing.
❷	Diskette Eject Button	Ejects a loaded diskette.
❸	Power Switch	Turns the computer on and off.
❹	Power-On Light	Turns on when the computer is turned on.
❺	Hard Drive Activity Light	Turns on when the hard drive is reading or writing.

The lights on the computer provide information about computer operation. When the power switch ❸ is turned on, the power-on light ❹ is green.

When the hard drive light ❺ or diskette drive light ❶ is on, the drive is either reading information from the disk or storing information on the disk.

1.4.2 Drive Positions

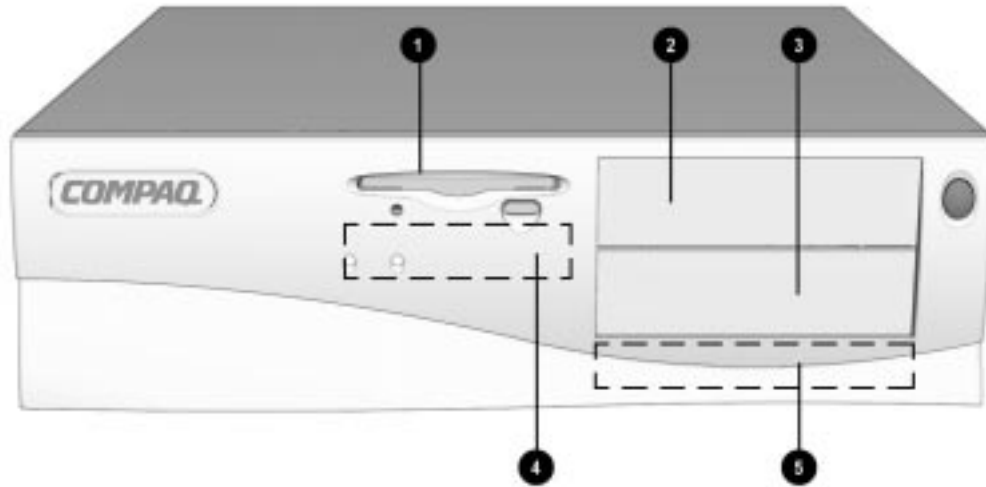


Figure 1-3. Drive Positions on the Compaq Deskpro 2000 Desktop Computer

The computer has space available for a combination of up to five mass storage devices. They may be installed in various configurations, including those shown in the following table.

Table 1-4
Compaq Deskpro 2000 Desktop Computer

Drive	Configuration
①	Standard 3.5-inch 1.44MB diskette drive
②	Optional diskette drive (5.25-inch or 3.5-inch), tape drive, hard drive, or CD-ROM drive (half-height)
③	Optional diskette drive (5.25-inch or 3.5-inch), tape drive, hard drive, or CD-ROM drive (half-height)
④	Primary hard drive bay (3.5-inch, third-height)
⑤	Primary hard drive bay (5.25-inch, third-height)

To verify the type, size, and capacity of the mass storage devices installed in the computer, run the View System Information (INSPECT) utility available at computer startup. Refer to Chapter 7, "Compaq Utilities," for more information.

- ✎ The computer may have either a 5.25-inch hard drive or a 3.5-inch hard drive installed. If the hard drive is a 5.25-inch drive, it will be installed in location ⑤. If the hard drive is a 3.5-inch drive, it will be installed in location ④.

1.4.3 Rear Panel Connectors

The following illustration shows the rear panel connectors on your desktop computer. Each connector is color-coded and includes an icon to help you identify its function.

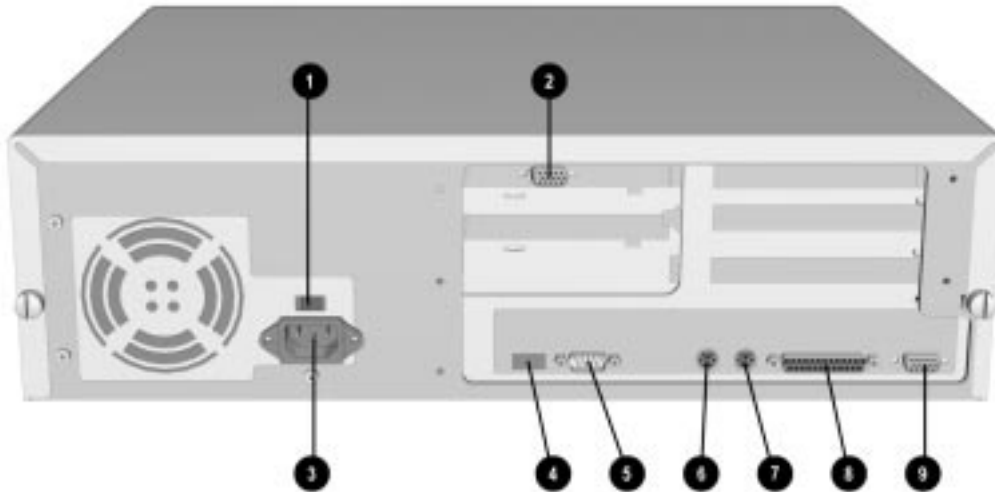


Figure 1-4. Rear Panel Connectors

Table 1-5
Rear Panel Connectors

Ref.	Component	Function
①	Voltage Select Switch	Switches voltage between 115 V (U.S.) and 230 V to match geographical requirements.
②	Monitor (Pentium Pro models only)	Connects a monitor to a graphics controller card. NOTE: The Matrox MGA Millennium graphics controller also includes a multimedia port.
③	Power Cord Connection	Connects the computer to an electrical power outlet.
④	Universal Serial Bus Connector (Pentium Pro models only)	Connects the computer to any peripheral while the computer is operating. Is a fully functional Plug and Play connector.
⑤	Serial Connector	Connects a serial device, such as a serial printer.
⑥	Keyboard Connector	Connects the keyboard.
⑦	Mouse Connector	Connects the mouse.
⑧	Parallel Connector	Connects a parallel device, such as a parallel printer.
⑨	Monitor Connector (Pentium models only)	Connects a monitor to an integrated graphics controller.

1.5 Minitower Computer Features

The Compaq Deskpro 2000 Minitower Personal Computer comes with a mouse and keyboard. You will also need a Compaq color monitor or other compatible monitor to operate your computer.

1.5.1 Front Panel Lights and Controls

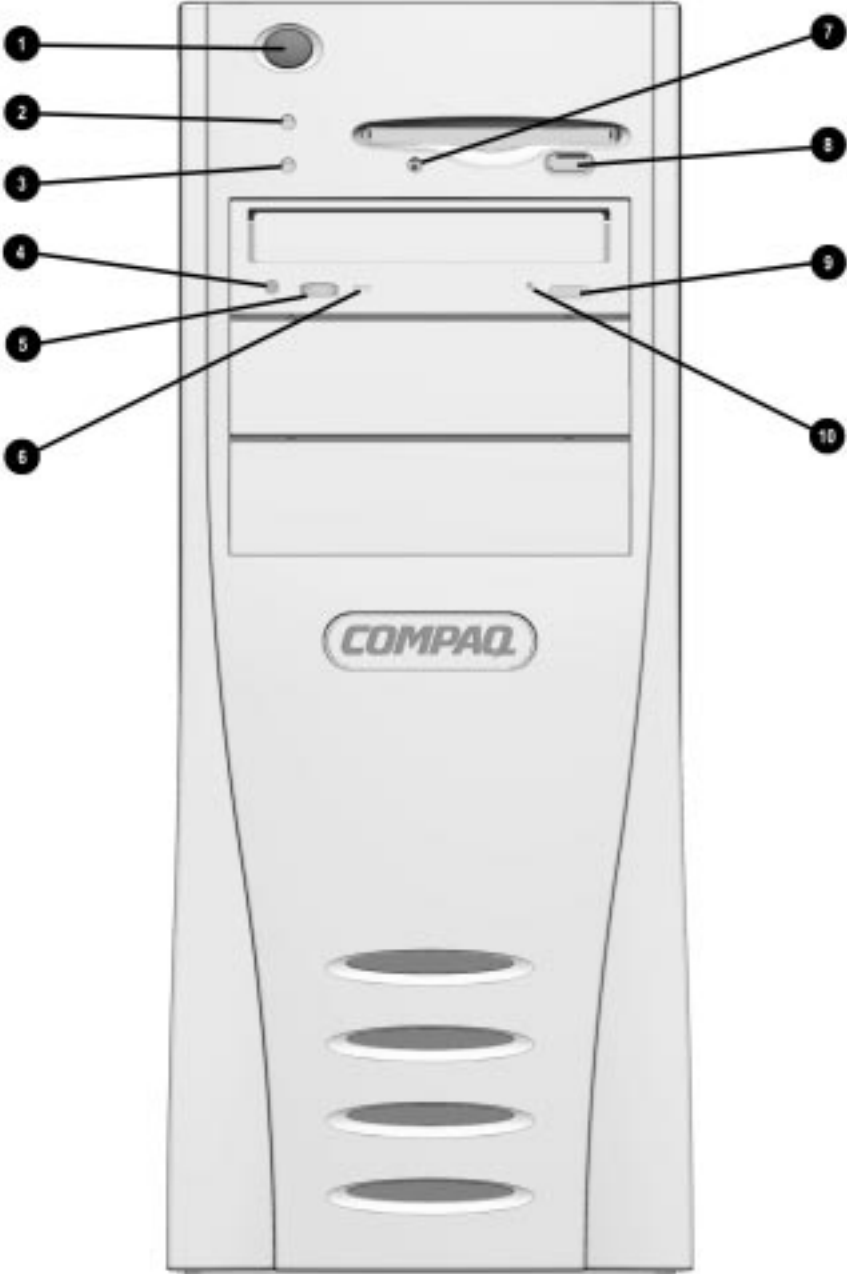


Figure 1-5. Power Switch and Front Panel Lights

**Table 1-6
Lights and Controls**

Ref.	Component	Function
①	Power Switch	Turns the computer on and off.
②	Power-On Light	Turns on when the computer is turned on.
③	Hard Drive Activity Light	Turns on when the hard drive is reading or writing.
④	CD-ROM Headphone Jack	Connects a headphone to the CD-ROM drive.
⑤	CD-ROM Headphone Volume Control	Increases and decreases the CD-ROM headphone volume.
⑥	CD-ROM Drive Activity Light	Turns on when the CD-ROM drive is reading.
⑦	Diskette Drive Activity Light	Turns on when the diskette drive is reading or writing.
⑧	Diskette Eject Button	Ejects a loaded diskette.
⑨	CD-ROM Eject Button	Opens and closes the CD-ROM tray.
⑩	CD-ROM Emergency Eject Hole	Manually ejects a CD if the eject button is inoperable.

The lights on the computer provide information about the computer's operation. When the power switch ① is turned on, the power-on light ② is green.

When the hard drive light ③, diskette drive light ⑦, or CD-ROM drive light ⑥ is on, the drive is either reading information from the disk or storing information on the disk.

1.5.2 Drive Positions

The computer has space available for a combination of up to five mass storage devices. They may be installed in various configurations, including those shown below.

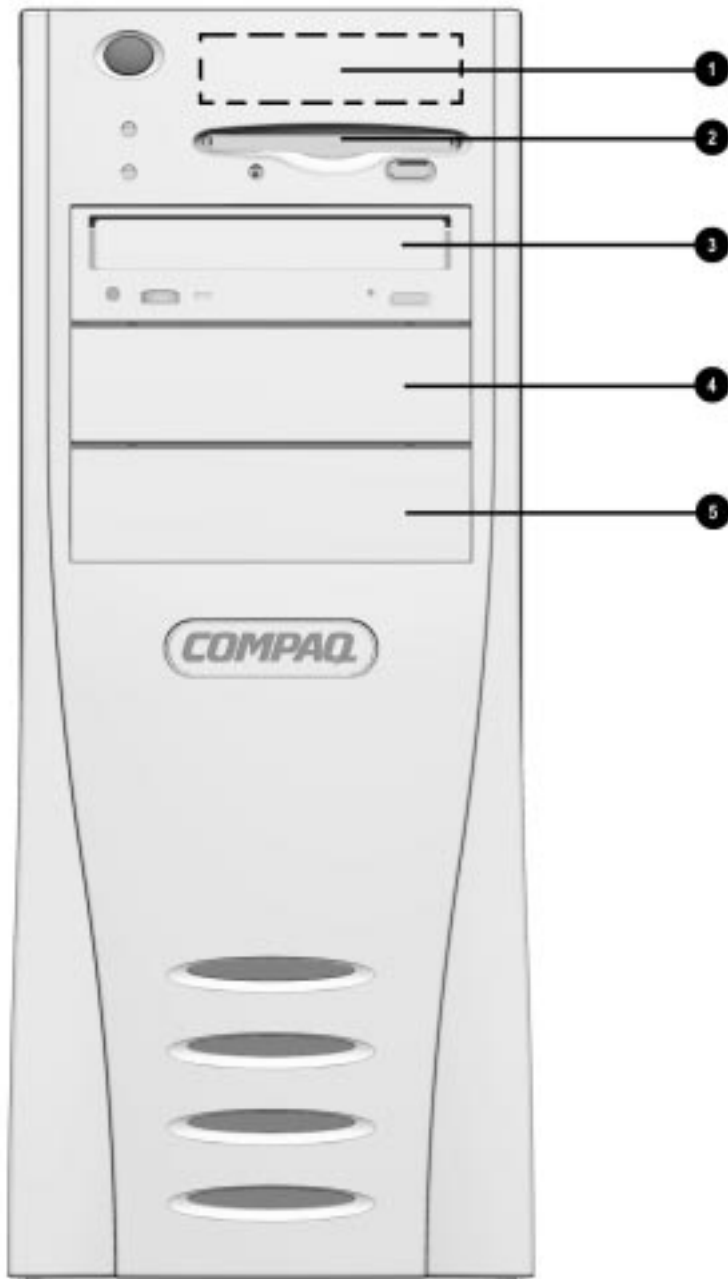


Figure 1-6. Drive Positions on the Minitower Computer

Table 1-7
Compaq Deskpro 2000 Minitower Computer

Drive	Configuration
❶	Primary hard drive bay (3.5-inch, third-height)
❷	Standard 3.5-inch 1.44MB diskette drive
❸	Optional diskette drive (5.25-inch or 3.5-inch), tape drive, hard drive or CD-ROM drive (half-height)
❹	Optional diskette drive (5.25-inch or 3.5-inch), tape drive, hard drive, or CD-ROM drive (half-height)
❺	Primary hard drive bay (5.25-inch, half-height) OR Optional diskette drive (5.25-inch or 3.5-inch), tape drive, hard drive, or CD-ROM drive (half-height)

To verify the type, size, and capacity of the mass storage devices installed in the computer, run Compaq Diagnostics in Windows, or run the View System Information (INSPECT) utility available at computer startup. Refer to Chapter 7, "Compaq Utilities," for more information.

- ✎ The computer may have either a 5.25-inch hard drive or a 3.5-inch hard drive installed. If the hard drive is a 5.25-inch drive, it will be installed in location ❺. If the hard drive is a 3.5-inch drive, it will be installed in location ❶.

1.5.3 Rear Panel Connectors

The following illustration shows the rear panel connectors of the minitower computer. Each connector is color-coded and includes an icon to help identify its function.

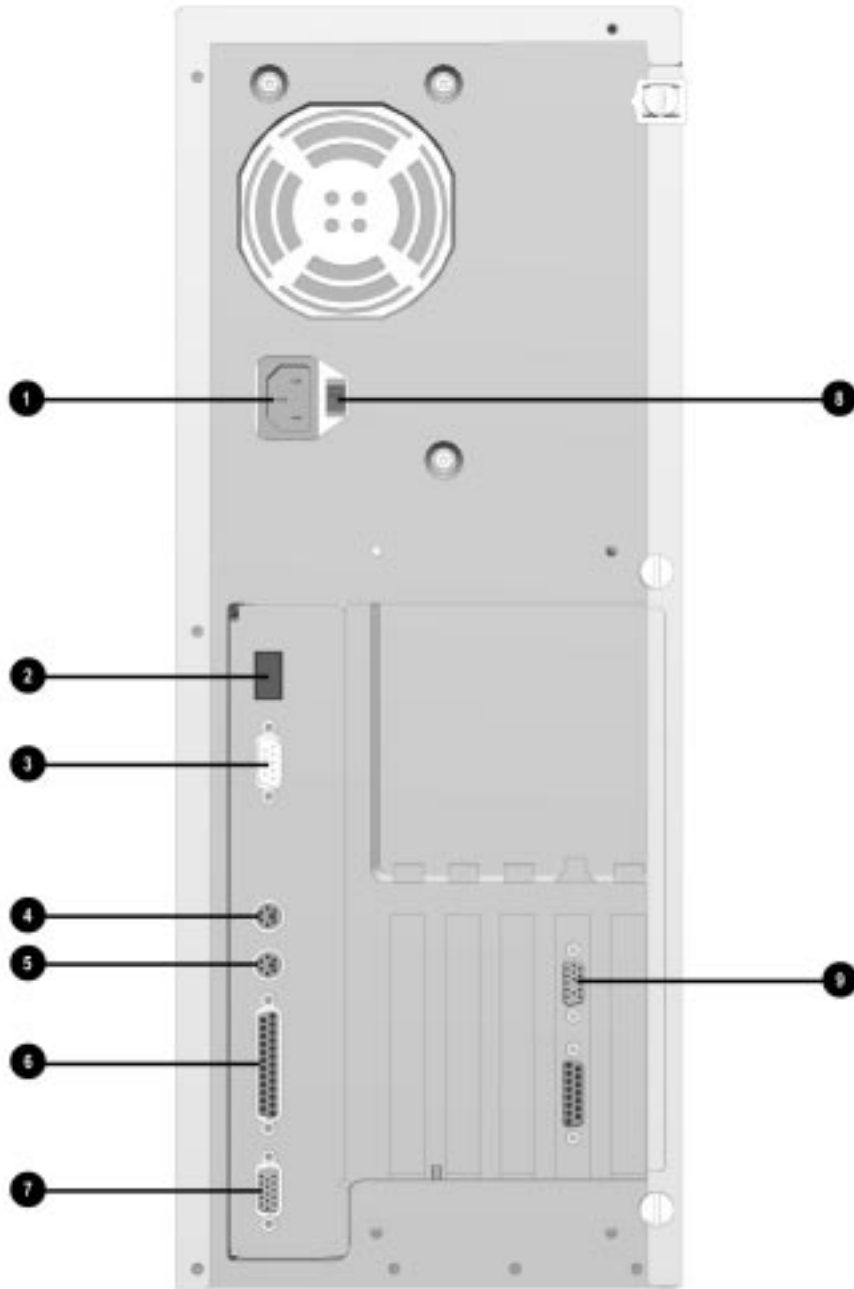


Figure 1-7. Rear Panel Connectors

Table 1-8
Rear Panel Connectors

Ref.	Component	Function
①	Power Cord Connector	Connects the computer to an electrical power outlet.
②	Universal Serial Bus Connector (Pentium Pro models only)	Connects the computer to any peripheral while the computer is operating. Is a fully functional Plug and Play connector.
③	Serial Connector	Connects a serial device, such as a serial printer.
④	Keyboard Connector	Connects the keyboard.
⑤	Mouse Connector	Connects the mouse.
⑥	Parallel Connector	Connects a parallel device, such as a parallel printer.
⑦	Monitor Connector (Pentium models only)	Connects a monitor to an integrated graphics controller.
⑧	Voltage Select Switch	Switches voltage between 115 V (U.S.) and 230 V to match geographical requirements.
⑨	Monitor Connector (Pentium Pro models only)	Connects a monitor to a graphics controller card.

NOTE: The Matrox MGA Millennium graphics controller also includes a multimedia port.

1.6 SpaceSaver Keyboard

The SpaceSaver keyboard has four principal typing areas and features Windows-specific keys:

- ① Main (typewriter) keypad.
- ② Function keys—**F1** through **F12**—at the top of the keyboard. Each key instructs the computer to carry out a specific task. In Program Manager or Windows Explorer, for example, pressing F1 usually causes help information to appear on the screen.
- ③ Windows Logo keys.
- ④ Windows Application key.
- ⑤ Arrow keys for moving the cursor up, down, right, and left.
- ⑥ Numeric (calculator style) keypad.

The numeric keypad has two operating modes, numeric and editing. When the **Num Lock** indicator light is on, the keypad is in the numeric mode and can be used like a calculator. To switch the keypad to the editing mode, press the **Num Lock** key (the light goes off).

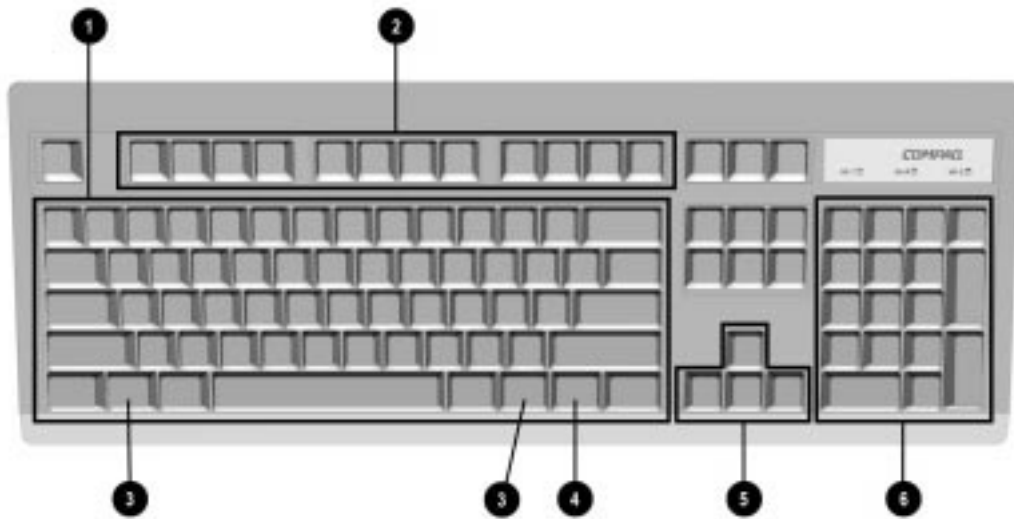


Figure 1-8. Keyboard Typing Areas

Three keys perform specific keyboard functions. The corresponding lights at the top of the keyboard indicate whether the keyboard functions are on or off (Num Lock ❶, Caps Lock ❷, and Scroll Lock ❸). The keyboard function is operating when the light is on.

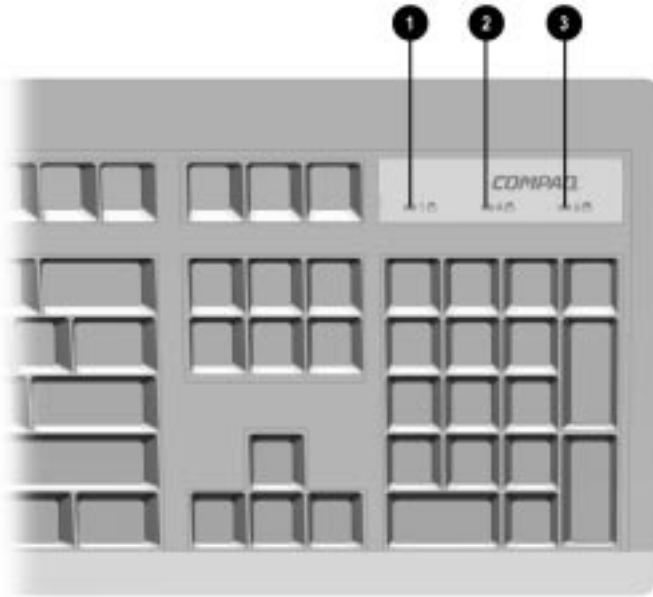


Figure 1-9. Keyboard Lights

The keyboard has feet on the bottom that enable the user to tilt the keyboard to a more comfortable typing angle.

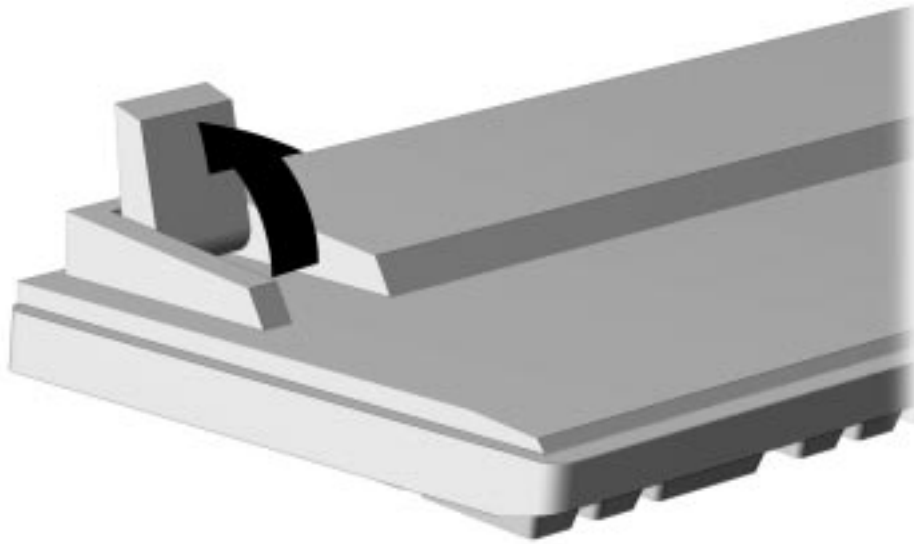


Figure 1-10. Keyboard Tilt Foot

Other function keys on the keyboard provide special functions, depending on the software application in use. These keys are illustrated below and described in the table which follows.

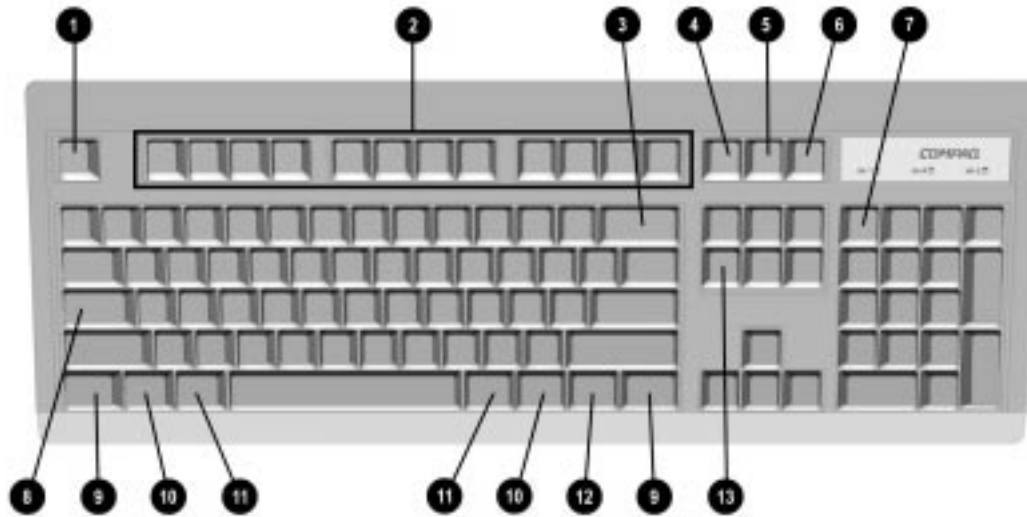


Figure 1-11. Special Function Keys

Table 1-9
Special Function Keys

Ref.	Key	Function
①	Esc	Often assigned a specific task by the application. Frequently used as an exit key (for quitting an application), for moving back one screen, or for canceling a command.
②	F1 - F12	Used for specific effects in applications and operating systems. Refer to the application software documentation.
③	Backspace	Moves the cursor left and deletes characters as it moves to the left.
④	Print Scrn	Depending on the software in use, prints the displayed screen to a printer. Using this key will not print the entire file.
⑤	Scroll Lock	When the Scroll Lock light is on, it prevents the screen from scrolling in some spreadsheet applications.
⑥	Pause	Temporarily suspends screen scrolling or some operations.
⑦	Num Lock	When the Num Lock light is on, the numeric keypad is activated and the arrow keys are deactivated. (The arrow keys to the left of the keypad perform the same functions as the arrow keys on the keypad.)
⑧	Caps Lock	When the Caps Lock light is on, all letters typed are capitalized.
⑨	Ctrl	Used in combination with another key, its effect depends on the software application you are using.
⑩	Windows Logo Keys	Opens the Windows Start menu. Used in combination with another key, its effect depends on the software application you are using.
⑪	Alt	Used in combination with another key, its effect depends on the software application you are using.
⑫	Windows Application Key	Opens a context menu for the software program you are using.
⑬	Delete	Deletes highlighted characters on the screen; otherwise, deletes one character at a time.
⑨ ⑪ ⑬	Ctrl+Alt+Delete	Holding down Ctrl and Alt while pressing Delete restarts the computer.

1.7 Options

The options that are available from Compaq for the Compaq Deskpro 2000 Series of Personal Computers are described in the following sections.

1.7.1 Processor Upgrade

The processors in the Compaq Deskpro 2000 Series of Personal Computers can be upgraded according to the schedule in the table below. Upgrade kits are not available from Compaq.

Base Processor	Can Be Upgraded To
P5/100	P5/120, P5/133, P5/166, and P5/200
P5/120	P5/133, P5/166, and P5/200
P5/133	P5/166 and P5/200
P5/166	P5/200
P6/180	P6/200

1.7.2 Mass Storage Options

The following mass storage options are available from Compaq for the Compaq Deskpro 2000 Series of Personal Computers:

- Diskette drives: 1.2-MB half-height diskette drive
- LS-120 drive: 1.44-/120-MB, 3.5-inch, third-height. The LS-120 drive will also read/write to 720-MB media.
- IDE hard drives: 1-GB and 2.0-GB
- SCSI-2 hard drives: 1.05-GB
- UltraSCSI hard drive: 2.1-GB
- CD-ROM drives:
 - SCSI: Quad-Speed internal CD-ROM drive and PD-CD drive (650-MB rewritable optical drive)
 - IDE: Quad-Speed CD-ROM drive and 8X CD-ROM drive
- Tape drives: 340/680-MB, 1.2-GB ACA, 2/8-GB DAT

1.7.3 Monitor Options

The following monitor options are available from Compaq for the Compaq Deskpro 2000 Series of Personal Computers:

- QVision 172 Color Monitor with AssetControl
- QVision 210 Color Monitor with AssetControl

- Compaq 140 Color Monitor
- Compaq 150 Color Monitor
- Compaq 1024 Color Monitor
- Compaq 151 FS Color Monitor with low emissions and AssetControl
- Compaq 171 FS Color Monitor with low emissions and AssetControl
- Compaq V70 Monitor

1.7.4 Graphics Controllers and Memory Options

The following graphics controller and memory options are available from Compaq for the Compaq Deskpro 2000 Series of Personal Computers:

- 1-MB EDO Video DRAM for Cirrus Logic 5436 and 5446 graphics controllers
- Matrox MGA Millennium graphics controller
- 2-MB or 6-MB Windows RAM (WRAM) Graphics Memory Module for Matrox MGA Millennium graphics controller

1.7.5 Serial/Parallel Interface Board

The serial/parallel interface board option is available from Compaq for the Compaq Deskpro 2000 Series of Personal Computers. This board uses an expansion slot and provides additional serial and parallel device support to the computer.

1.7.6 Network Communications Options

The following network communications options are available from Compaq for the Compaq Deskpro 2000 Series of Personal Computers:

- IBM CompatibleAuto 16/4 Token Ring ISA Adapter
- NetFlex ENET/ISA Controller
- External AUI to BNC Ethernet Transceiver
- Netelligent 10/100TX PCI UTP
- Netelligent 10T PCI UTP
- Netelligent 4/16 TR PCI IBM UTP/STP

1.7.7 Scanner Keyboard

The Scanner Keyboard provides an integrated scanner that replaces multiple hardware/software products to fax, copy, file and scan paper-based information.

1.7.8 PD-CD Drive

The PD-CD Drive is a "two drives in one" device in that it is a rewritable optical drive and a CD-ROM drive. It is a 5.25-inch, half-height, tray-load device that uses phase-change dual technology to simultaneously erase and write on the media at 2X speed and reads at 4X speed. The interface is internal SCSI.

1.7.9 Modems

The Compaq internal 28.8 Data/Fax modem is available from Compaq for the Compaq Deskpro 2000 Series of Desktop Personal Computers. This modem is available in the U.S. only.

1.7.10 Software Options

The following software options are available from Compaq for the Compaq Deskpro 2000 Series of Personal Computers:

- MS-DOS 6 (3.5-inch diskettes)
- Corporate license agreements for MS-DOS 6
- MS-DOS 6 LicensePak
- MS-DOS 6 corporate upgrade (100+ users)
- MS-DOS 6 LicensePak upgrade
- Netware, version 3.12 (dependent on number of users)
- Netware, version 3.12 (CD-ROM, dependent on number of users)
- Netware, version 4.0 (dependent on number of users)
- Compaq EDGE for Netware
- Netware management agents
- Netware services manager
- SCO UNIX O/S from Compaq version 4.1 (with media kit)
- SCO UNIX network bundle from Compaq version 4.1 (with media kit)
- SCO UNIX and TCP/IP Development System from Compaq release 1.2
- SCO XSight Runtime version 4.1
- Open Server Ethernet System, SCO 2.0
- Open Server Network System, release 3.0
- Open Desktop Development System, release 3.0
- Windows NT Support for Windows NT is optimized on the Pentium 51xx series

chapter 2

TROUBLESHOOTING

This chapter provides troubleshooting information for the Compaq 2000 Series of Personal Computers. The four levels of troubleshooting for the computer are:

- Power-On Self-Test (POST)
- Computer Setup
- Compaq Diagnostics
- Troubleshooting without diagnostics

Power-On Self-Test (POST) messages, Diagnostics error codes, and memory error codes are included in the tables.

The messages and codes appear in tables that include a description of the error, the probable cause, and the recommended action that should be taken to resolve the error condition.

Adherence to the procedures and precautions described in this chapter is essential for proper service.

2.1 Power-On Password

The power-on password prevents use of the computer until the password is entered.

If the power-on password is set, a key icon (⌨) appears on the screen when POST completes. If this occurs, enter the password to continue. If you enter the password incorrectly, a broken key icon (⌨~~) is displayed. Try again. After three unsuccessful tries, you must turn off the computer, then on again before you can continue. To delete the password, type the current password immediately followed by a slash (/) and press **Enter**.~~

✎ If you don't have access to the power-on password, disable the power-on password by completing the following procedures:

1. Complete the preparation for disassembly procedures in Chapter 4.
2. If your computer is a desktop model, remove the hood. This is described in Chapter 5.

If your computer is a minitower model, remove the left side access panel as described in Chapter 5.

3. To disable or clear the power-on password, move the jumper plug on E6 from pins 5 and 6 to pins 6 and 7 and then restart the computer.
- ✎ To enable the power-on password, turn the computer off, then move the jumper plug from pins 6 and 7 to pins 5 and 6 and restart the computer. The password can then be reestablished through Security Management.

The E6 jumper location is shown in Figure 2-1.

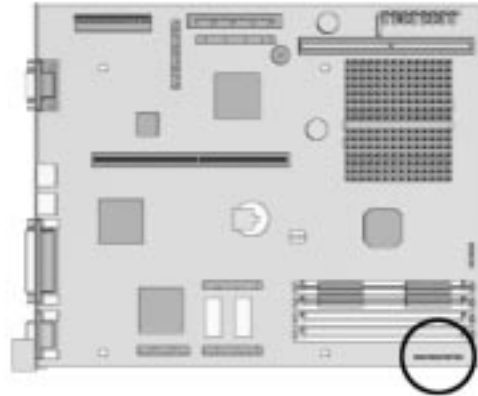
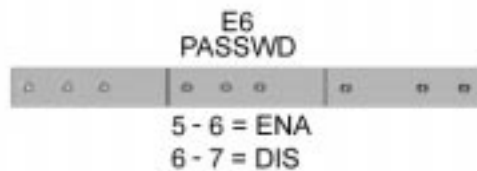


Figure 2-1. Locating the E6 Jumper on the System Board

4. Replace the hood or access panel and perform the desired troubleshooting.
5. The password can then be reestablished through Security Management.

2.2 Power-On Self-Test (POST)

POST is a series of diagnostic tests that run automatically when the system is turned on. After the computer is turned on, POST checks the following assemblies to ensure that the computer system is functioning properly:

- Keyboard
- Mouse
- System board
- Memory modules
- Video
- Diskette drives
- Hard drives
- Power supply
- Controllers

POST also detects the type of mass storage devices installed in the computer.

If POST finds an error in the system, an error condition is indicated by an audible and/or visual message. Table 2-1 gives explanations of the error codes and a recommended course of action.

2.2.1 Power-On Self-Test Messages

An error message results if the Power-On Self-Test encounters a problem. This test runs when the system is turned on, checking assemblies within the computer and reporting any errors it finds.

**Table 2-1
Power-On Self-Test Messages**

Message	Beeps*	Probable Cause	Recommended Action
101-ROM Error	1L,1S	System ROM checksum.	Replace the system board.
101-Option ROM Checksum Error	1L, 1S	Option ROM checksum.	Replace the system board..
102-System Board Failure	None	DMA, timers, etc.	Replace the system board.
162-System Options Error	2S	No diskette drive or mismatch in drive type.	Run Computer Setup.
162-System Options Not Set	2S	Configuration incorrect.	Run Computer Setup.
163-Time & Date Not Set	2S	Invalid time or date in configuration memory	Run Computer Setup.
164-Memory Size Error	2S	Configuration memory incorrect.	Run Computer Setup.
201-Memory Error	None	RAM failure.	1. Run Computer Setup. 2. Replace memory module(s) as required. 3. Replace system board.
202-Memory Type Mismatch	2S	One FPM SIMM and one EDO SIMM installed in the same bank.	Populate the memory bank with two EDO SIMMs or two FPM SIMMs. EDO SIMMS cannot be mixed with FPM SIMMs.
203-Memory Address Error	None	RAM failure.	1. Run Computer Setup. 2. Replace memory module(s) as required. 3. Replace system board.
205-Memory Error	None	Cache memory error.	1. Run the Configuration and Diagnostics utilities. 2. Replace cache.
207-ECC Corrected Single Bit Errors in DIMM/SIMM Pair(s) X, Y, Z	2S	Memory error detected and corrected in SIMMs X, Y, Z	1. Swap one DIMM/SIMM from defective bank with good DIMM/SIMM. Replace DIMM/SIMM that the error message follows. 2. Replace system board.

*L = Long, S = Short

Continued

Table 2-1 Continued

Message	Beeps*	Probable Cause	Recommended Action
301-Keyboard Error	None	Keyboard failure.	Reconnect keyboard with computer turned off.
301-Keyboard Error or Text Fixture Installed	None	Keyboard failure.	1. Reconnect keyboard with computer turned off. 2. Replace the keyboard.
303-Keyboard Controller Error	None	I/O board keyboard controller.	1. Reconnect keyboard with computer turned off. 2. Replace the system board.
304-Keyboard or System Unit error	None	Keyboard failure	1. Reconnect keyboard with computer turned off. 2. Replace the keyboard. 3. Replace the system board.
40X Parallel Port X Address Assignment Conflict	2S	Both external and internal ports are assigned to parallel port X.	Run Computer Setup.
402-Monochrome Adapter Failure	1L, 2S	Monochrome display controller.	Replace the monochrome display controller,
501-Display Adapter Failure	1L,2S	Video display controller.	1. Replace the graphics board (if installed). 2. Replace the system board.
601-Diskette Controller Error	None	Diskette controller circuitr.	1. Check and/or replace cables. 2. Replace the system board.
605-Diskette Drive Type Error	2S	Mismatch in drive type.	Run Computer Setup.
611-Primary Floppy Port Address Assignment Conflict	2S	Configuration error.	Run Computer Setup.
612-Secondary Floppy Port Address Assignment Conflict	2S	Configuration error.	Run Computer Setup.
702-A Coprocessor Has Been Detected That Is Not Reported In CMOS	None	Configuration error.	Run Computer Setup.
703- CMOS Reports a Coprocessor That Has Not Been Detected By POST	2S	Configuration error.	Run Computer Setup.
1151-System Board COMM Port 1 Address Assignment Conflict	2S	Both external and internal serial ports are assigned to COM1.	Run Computer Setup.
1152-System Board COMM Port 2 Address Assignment Conflict	2S	Both external and internal serial ports are assigned to COM2.	Run Computer Setup.
1155-System Board COMM Port Address Assignment Conflict	2S	Both external and internal serial ports assigned to same COMM port.	Run Computer Setup.

*L = Long, S = Short

Continued

Table 2-1 *Continued*

Message	Beeps*	Probable Cause	Recommended Action
1205-System Board I/O Conflict Detected Device ID = XXXYYYY	2S	A system board device is conflicting with an external add-in device.	Run Computer Setup.
1720-IntelliSafe Hard Drive detects imminent failure	None	Hard drive is about to fail.	Back up contents and replace hard drive.
1780-Disk 0 Failure	None	Hard drive/format error.	1. Run the Configuration and Diagnostics utilities. 2. Replace hard drive.
1781-Disk 1 Failure	None	Hard drive/format error.	1. Run the Configuration and Diagnostics utilities. 2. Replace hard drive.
1782-Disk Controller	None	Hard drive circuitry error.	1. Run the Configuration and Diagnostics utilities. 2. Replace hard drive.
1790-Disk 0 Failure	None	Hard drive error or wrong drive type.	1. Run the Configuration and Diagnostics utilities. 2. Replace hard drive.
1791-Disk 1 Failure	None	Hard drive error or wrong drive type.	1. Run the Configuration and Diagnostics utilities. 2. Replace hard drive.
1800-Temperature Alert	None	Internal temperature exceeds specification.	Check that computer air vents are not blocked and cooling fan is running.
Hard Drive Parameter Table or BIOS Error system Halted	3L	Configuration or hardware failure.	Run the Configuration and Diagnostics utilities.
IOCHECK Active Slot X	None	Defective board in slot X.	Run the Configuration and Diagnostics utilities.
Bus Master Timeout Slot X	None	Defective board in slot X.	Run the Configuration and Diagnostics utilities.
Invalid Electronic Serial Number	None	Electronic serial number has become corrupted.	Run Compaq Utilities.
Audible	2S	Power-on successful.	None.
(RESUME = F1 KEY)	None	As indicated to continue.	Press F1 .

* L = Long, S = Short

2.3 Compaq Configuration and Diagnostics

This section explains how to use the Configuration and Diagnostics utilities installed on the computer or on diskettes.

IMPORTANT: If you are planning to run an alternate operating system (e.g., OS/2 or UNIX), you will need to configure the system using the Compaq Diagnostics diskette, which can be obtained from Compaq (see Chapter 3). Failure to configure the system can result in loss of data and reduced hard drive capacity.

Compaq Diagnostics is installed on the hard drive of the computer. The Diagnostics are also available on diskettes.

Both Windows and DOS have configuration and diagnostic utilities that are available by selecting options from the Compaq Configuration and Diagnostics menu. These utilities should be accessed in the following instances:

- When a system configuration error is detected during the Power-On Self-Test (POST).
- To change factory default settings for some of the computer features.
- To change the system configuration, which is sometimes necessary when you add or remove optional hardware.
- To set system configuration features.

To display the Configuration and Diagnostics menu, restart the computer, then press **F10** when the square cursor displays in the upper-right corner of the screen. Full instructions are presented later in this section. Diagnostics are available by selecting the Computer Checkup (TEST) utility on the Configuration and Diagnostics menu.

- ✍ The diagnostics and setup utilities are located on a hard disk partition in the computer, not in the ROM. Information about recreating the diagnostics/setup partition is presented later in this section.
- ✍ Utilities similar to some of those present in the Compaq Configuration and Diagnostics menu can be found in DOS, Windows 3.1, and Windows 95. For example, configuration and installation utilities are also available in the Windows 95 Control Panel utility Add New Hardware.

2.3.1 Preparing the Computer

If you encounter an error condition, complete the following steps before starting problem isolation procedures:

1. Ensure proper ventilation. The computer should have a 3-inch (7.6-cm) clearance at the back of the system unit.
2. Turn off the computer and peripheral devices.



CAUTION: Always ensure that the power is off before disconnecting or reconnecting the mouse, keyboard, or any other peripheral devices. Disconnecting or connecting any peripheral devices while the unit power is on can damage the system board.

3. Disconnect any peripheral devices other than the monitor and keyboard. Do not disconnect the printer if you want to test it or use it to log error messages.
4. Install loop-back and terminating plugs for complete testing.
5. Run the Configuration and Diagnostics utilities.

2.3.2 Accessing the Configuration and Diagnostics Menu


You can access the Configuration and Diagnostics utilities at startup from the hard drive or from the diskettes. Procedures for both methods are presented below. Both procedures display the Configuration and Diagnostics menu. Your particular menu may differ slightly from the one shown in Figure 2-2.

Accessing the Configuration and Diagnostics Menu at Startup

To display the menu immediately after startup, complete the following steps:

1. Turn on or restart the computer. If Windows 3.1 or Windows NT is running, exit Windows and press **Ctrl+Alt+Delete**. If Windows 95 is running, select Start, Shut Down, Restart the computer.

Immediately after the computer completes Power-On Self-Test (POST), which is indicated on the screen by the memory check, the computer beeps twice and the cursor moves to the upper-right corner of the screen.

 The memory check only occurs on a cold boot.

2. Press **F10** as soon as the cursor moves to the upper-right corner of the screen.
3. If prompted, select the desired language.

4. Press **Enter** at the Welcome to Compaq Utilities screen.
5. A menu similar to the one shown in Figure 2-2 is displayed. You are prompted through any procedure that you select.

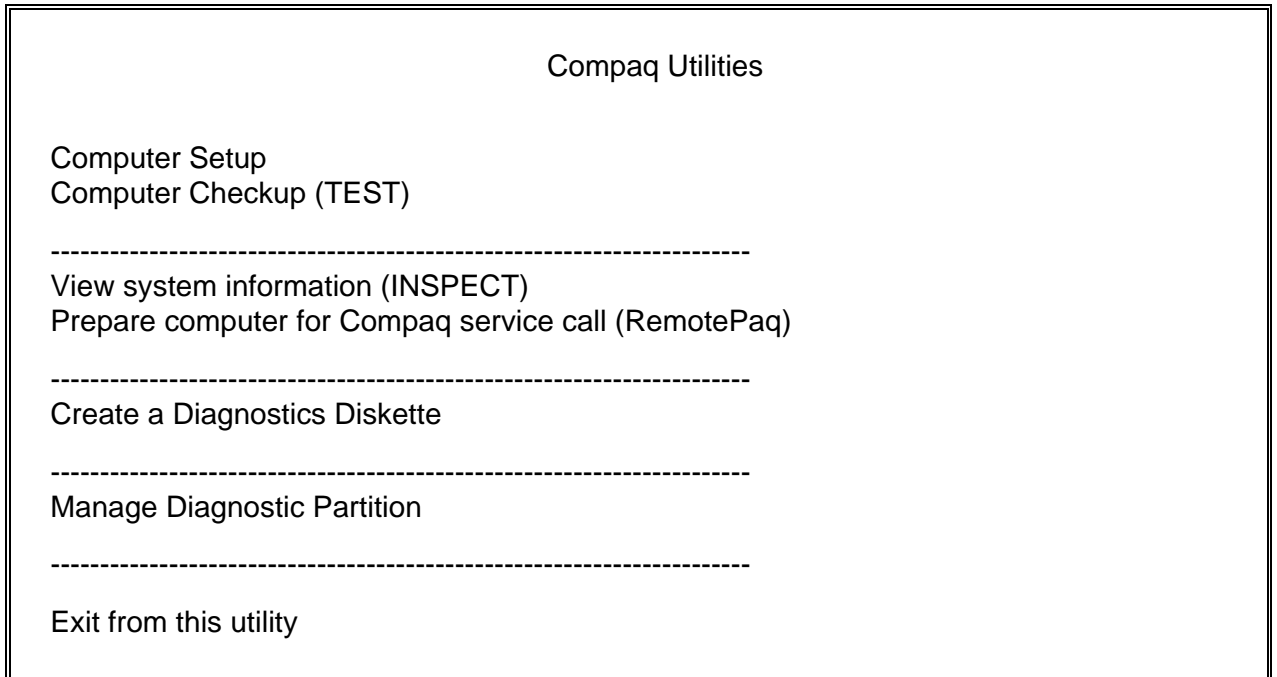



Figure 2-2. Configuration and Diagnostics Menu

Accessing the Configuration and Diagnostics Menu from Diskette

You can load either the Setup or Diagnostics diskette with this procedure. To load either of the diskettes, complete the following steps:

1. Insert the diskette into drive A.
2. Turn on or restart the computer. If Windows 3.1 is running, exit Windows and press **Ctrl+Alt+Delete**. If Windows 95 is running, select Start, Shut Down, Restart the computer.

Immediately after the computer completes Power-On Self-Test (POST), which is indicated on the screen by the memory check, the computer beeps twice and the cursor moves to the upper-right corner of the screen.

 The memory check only occurs on a cold boot.

3. Press **F10** as soon as the cursor moves to the upper-right corner of the screen.
4. If prompted, select the desired language.
5. Press **Enter** at the Welcome to Compaq Utilities screen.
6. If you load the Diagnostics diskette, a menu similar to the one shown in Figure 2-2 is displayed. If you select Computer Setup from this menu, you are prompted to insert the Setup diskette. You are prompted through any procedure that you select.

2.3.3 Using Configuration and Diagnostics Menu Options

The Configuration and Diagnostics menu contains the following utilities:

- Computer Setup
- Computer Checkup (TEST)
- View System Information (INSPECT)
- Prepare computer for Compaq Service Call (RemotePaq)
- Create a Diagnostics Diskette
- Manage Diagnostics Partition

See the user documentation for descriptions of the Security Management and Power Management utilities. A brief description of each of the troubleshooting utilities is presented below. Ample prompting is provided with each of these utilities.

The Computer Setup utility is selected from the Configuration and Diagnostics Menu. It is preinstalled on the hard drive and is also available on diskette. It gives a snapshot of the computer's hardware configuration, aids in troubleshooting, and allows you to set custom features. Computer Setup recognizes a newly installed internal or external device and automatically updates the Computer Setup screen. The following parameters are reported:

- Processor and memory
- Storage
- Input devices
- Power management
- Video
- Communications
- Security management

Press **F1** for instructions on how to navigate around the screen.

Computer Checkup (TEST)

Computer Checkup (TEST), the primary diagnostics utility, confirms whether the various computer devices are recognized by the system and are functioning properly. Use the TEST utility to help set up, to test the computer, and to install the operating system. The TEST menu offers the following:

- Quick Check Diagnostics runs a quick, general test on each device with a minimal number of prompts. If errors occur, they are displayed when the test is complete.
- Automatic Diagnostics runs unattended and provides maximum testing of each device with minimal prompts. You can choose how many times to run the tests, to stop on errors, or to print or file a log of errors.
- Prompted Diagnostics allows maximum control over the device testing process. You can choose attended or unattended testing, decide to stop on errors, or choose to print or file a log of errors.
- View Device List provides a list of all devices installed in the computer,
- Exit Diagnostics allows you to exit the Diagnostics utility.

The TEST option, which may vary by product, checks the following:

- CPU (main system)
- Keyboard
- Pointing device interface
- Parallel interfaces
- System memory
- Graphics controllers
- Diskette drives
- Hard disks
- Serial interfaces
- Installed Compaq devices (tape drive, SCSI device, CD-ROM drive, or network status)

Running TEST

To run TEST, complete the following steps:

1. From the Configuration and Diagnostics menu, select the Computer Checkup (TEST) option.
A test option menu is displayed.
2. Select the option to view the device list.
A list of the installed hardware devices is displayed.
3. Verify that the TEST utility correctly detected the devices installed.

✎ This utility may not detect non-Compaq devices.

- If the list is correct, select **OK**.

The test option menu is displayed again.

- If the list is incorrect, be sure that any new devices are installed properly.

4. Select one of the following from the test option menu:

- **Quick Check Diagnostics** runs a quick, general test on each device with a minimal number of prompts. If errors occur, they are displayed when the testing is complete.
- **Automatic Diagnostics** runs unattended, maximum testing of each device with minimal prompts. You can choose how many times to run the tests, to stop on errors, or to print or file a log of errors.
- **Prompted Diagnostics** allows maximum control over the device testing process. You can choose attended or unattended testing, decide to stop on errors, or choose to print or file a log of errors.

✎ Choosing attended testing allows data-destructive tests.

✎ When you run the TEST utility, be sure to record any error message numbers.

5. Follow the instructions on the screen as the diagnostic tests are run on the devices.

When the testing is complete, the test option menu is displayed again.

6. Exit to the Configuration and Diagnostics menu.

View System Information (INSPECT)

The View System Information (INSPECT) utility provides information about the system once it has been configured. INSPECT operates with MS-DOS and provides information about the system operating environment, including:

- System
- Operating system
- ROM
- System storage
- System ports
- System files
- Memory
- Keyboard
- Graphics
- Windows files
- Miscellaneous

The options available from this utility are:

- Print the inspect status.
- Save the inspect status to a file.
- Add comments to a parameter status.
- Exit the utility.

RemotePaq

This utility is available in some geographical areas and requires a modem. The utility allows Compaq Customer Support to automatically run diagnostics on the machine.

Create a Diagnostics Diskette

This option allows you to back up the diagnostics software onto two diskettes.

- ✎ Compaq highly recommends that the Configuration and Diagnostics diskette be created as soon as the system is configured. This software is required to troubleshoot the system if the hard drive cannot be accessed or must be replaced.

Manage Diagnostics Partition

This option allows you to create, delete, or upgrade the diagnostics software on your computer. This option can only be run from a diskette.



CAUTION: Creating a Diagnostics Partition involves performing a low-level format on the hard drive. This is normally done only to add diagnostics to a new replacement hard drive. If the diagnostics software is deleted, you will no longer be able to access the Configuration and Diagnostics menu.

2.3.4 Compaq Diagnostics for Windows

Compaq Diagnostics for Windows utility contains the same utilities as the partition-based INSPECT program, but in a Windows environment. To use the Compaq Diagnostics for Windows utility in Windows 3.1, select the Compaq Diagnostics icon from the Compaq Utilities group box. To use the Compaq Diagnostics for Windows utility in Windows 95, select the Compaq Diagnostics icon from the Control Panel group box that opens when you select StartUp ==> Programs ==> Control Panel or by selecting StartUp ==> Programs ==> Compaq Utilities.

Once the program is running, you can use the tool bar or the menus to browse through the information. Some examples of the information you can view are:

- System
- Asset control
- Input devices
- Communication
- Storage
- Video
- Memory
- Multimedia
- Preferences
- Operating system
- Windows
- Health

2.4 Diagnostic Error Codes

Diagnostic error codes occur if the system recognizes a problem while running the Compaq Diagnostics program. These error codes help identify possible defective subassemblies.

Tables 2-2 through 2-15 list possible error codes, descriptions of each error condition, and actions required to resolve the error condition.

- ✎ Retest the system after completing each step. If the problem has been resolved, do not proceed with the remaining steps.

For assistance in the removal and replacement of a particular subassembly, see Chapter 5, "Removal and Replacement Procedures."

Table 2-2
Microprocessor Test Error Codes

Error Code	Description	Recommended Action
101-xx	CPU test failed.	Replace the system board and retest.
102-xx	Coprocessor error.	1. Run Computer Setup and retest. 2. Replace the processor and retest.
103-xx	DMA controller failed.	Replace the system board and retest.
104-xx	Interrupt controller failed.	Replace the system board and retest.
105-xx	Port 61 error.	Replace the system board and retest.
106-xx	Keyboard controller self-test failed.	Replace the system board and retest.
107-xx	CMOS RAM test failed.	Replace the system board and retest.
108-xx	CMOS interrupt test failed.	Replace the system board and retest.
109-xx	CMOS clock test failed.	Replace the system board and retest.
110-xx	Programmable timer test failed.	The following step applies to error codes 110-xx through 113-01:
113-01	Protected mode test failed.	Replace the system board and retest.
114-01	Speaker test failed.	1. Verify the speaker connection. 2. Replace the system board and retest.

Table 2-3
Memory Test Error Codes

Error Code	Description	Recommended Action
200-xx	Memory machine ID test failed.	Reinsert memory modules in correct location
202-xx	Memory system ROM checksum failed	The following steps apply to error codes 202-xx through 215-xx:
203-xx	Memory write/read test failed	1. Remove one memory module at a time until the error message stops.
204-xx	Memory address test failed.	2. Replace removed modules one at a time, testing each to ensure the error does not return.
211-xx	Random pattern test failed.	3. Replace defective memory module.
214-xx	Noise test failed.	4. Replace the system board and retest.
215-xx	Random address test failed	

Table 2-4
Keyboard Test Error Codes

Error Code	Description	Recommended Action
300-xx	Keyboard ID test failed.	The following steps apply to error codes 300-xx through 304-xx:
301-xx	Keyboard self-test/interface test failed.	1. Check the keyboard connection. If disconnected, turn the computer off and connect the keyboard.
302-xx	Individual key test failed.	2. Replace the keyboard and retest.
304-xx	Keyboard repeat test failed	3. Replace the system board and retest.

Table 2-5
Parallel Printer Test Error Codes

Error Code	Description	Recommended Action
401-xx	Printer failed or not connected.	The following steps apply to 401-xx through 403-xx: 1. Connect the printer. 2. Check power to the printer. 3. Check the printer cable. 4. Install the loop-back connector and retest. 5. Replace system board and retest.
402-xx	Printer port test failed.	
403-xx	Printer pattern test failed.	

Table 2-6
Diskette Drive Test Error Codes

Error Code	Description	Recommended Action	
600-xx	Diskette ID drive types test failed.	The following steps apply to error codes 600-xx through 698-xx: 1. Replace the diskette media and retest. 2. Check and/or replace the diskette power and signal cables and retest. 3. Replace the diskette drive and retest. 4. Replace the system board and retest.	
601-xx	Diskette format failed		
602-xx	Diskette read test failed.		
603-xx	Diskette write, read, compare test failed.		
604-xx	Diskette random seek test failed.		
605-xx	Diskette ID media test failed.		
606-xx	Diskette speed test failed.		
609-xx	Diskette reset controller failed.		
610-xx	Diskette change line test failed.		
697-xx	Diskette type error.		
698-xx	Diskette drive speed not within limits.		
699-xx	Diskette drive/media error.		1. Replace media. 2. Run Computer Setup and Computer Checkup.

Table 2-7
Serial Test Error Codes

Error Code	Description	Recommended Action
1101-xx	Serial port test failed.	1. Run Computer Setup. 2. Replace the system board and retest.

Table 2-8
Modem Communications Test Error Codes

Error Code	Description	Recommended Action
1201-xx	Modem internal test failed.	The following steps apply to error codes 1201-xx through 1210-xx: 1. Disconnect from the phone line and retest. 2. Check the phone number. 3. Check the modem line. 4. Replace the modem and retest.
1202-xx	Modem time-out test failed.	
1203-xx	Modem external termination test failed.	
1204-xx	Modem auto originate test failed.	
1205-xx	Modem auto answer test failed.	
1210-xx	Modem direct connect test failed.	

**Table 2-9
Hard Drive Test Error Codes**

Error Code	Description	Recommended Action
1701-xx	Hard drive format test failed.	The following steps apply to error codes 1701-xx through 1736-xx: 1. Run Computer Setup and verify drive type. 2. Replace the hard drive signal and power cables and retest. 3. Replace the hard drive and retest. 4. Replace the system board and retest.
1702-xx	Hard drive read test failed.	
1703-xx	Hard drive write/read/compare test failed.	
1704-xx	Hard drive random seek test failed.	
1705-xx	Hard drive controller test failed.	
1706-xx	Hard drive ready test failed.	
1707-xx	Hard drive recalibration test failed.	
1708-xx	Hard drive format bad track test failed.	
1709-xx	Hard drive reset controller test failed.	
1710-xx	Hard drive park head test failed.	
1715-xx	Hard drive head select test failed.	
1716-xx	Hard drive conditional format test failed.	
1717-xx	Hard drive ECC* test failed.	
1719-xx	Hard drive power mode test failed.	
1724-xx	Hard drive network preparation test failed.	
1736-xx	Hard drive monitoring test failed.	

*ECC=Error Correction Code

**Table 2-10
Tape Drive Test Error Codes**

Error Code	Description	Recommended Action
1900-xx	Tape drive ID test failed.	The following steps apply to error codes 1900-xx through 1906-xx: 1. Replace the tape cartridge and retest. 2. Check the switch settings on the adapter board (if applicable). 3. Check and/or replace the signal cable and retest (if applicable). 4. Replace the tape adapter board (if applicable) and retest. 5. Replace the tape drive and retest. 6. Replace the system board and retest.
1901-xx	Tape drive servo test failed.	
1902-xx	Tape drive format or format verification test failed.	
1903-xx	Tape drive sensor test failed.	
1904-xx	Tape drive BOT/EOT test failed.	
1905-xx	Tape drive read test failed.	
1906-xx	Tape drive write/read/compare failed.	

**Table 2-11
Video Test Error Codes**

Error Code	Description	Recommended Action	
501-xx	Video controller test failed.	The following error codes apply to error codes 501-xx through 516-xx: 1. Replace the monitor and retest. 2. Replace the system board.	
502-xx	Video memory test failed.		
503-xx	Video attribute test failed.		
504-xx	Video character set test failed.		
505-xx	Video 80 × 25 mode 9 × 14 character cell test failed.		
506-xx	Video 80 × 25 mode 8 × 8 character cell test failed.		
507-xx	Video 40 × 25 mode test failed.		
508-xx	Video 320 × 200 mode color set 0 test failed.		
509-xx	Video 320 × 200 mode color set 1 test failed.		
510-xx	Video 640 × 200 mode test failed .		
511-xx	Video screen memory page test failed.		
512-xx	Video gray scale test failed.		
514-xx	Video white screen test failed.		
516-xx	Video noise pattern test failed.		
2402-xx	Video memory test failed.		The following steps apply to error codes 2402-xx through 2456-xx: 1. Run the Configuration and Diagnostics utilities. 2. Replace the monitor and retest. 3. Replace the video board and retest (if applicable). 4. Replace the system board.
2403-xx	Video attribute test failed.		
2404-xx	Video character set test failed.		
2405-xx	Video 80 × 25 mode 9 × 14 character cell test failed.		
2406-xx	Video 80 × 25 mode 8 × 8 character cell test failed.		
2408-xx	Video 320 × 200 mode color set 0 test failed.		
2409-xx	Video 320 × 200 mode color set 1 test failed.		
2410-xx	Video 640 × 200 mode test failed.		
2411-xx	Video screen memory page test failed.		
2412-xx	Video gray scale test failed.		
2414-xx	Video white screen test failed.		
2416-xx	Video noise pattern test failed.		
2418-xx	ECG/VGC memory test failed.		

Continued

Table 2-11 *Continued*

Error Code	Description	Recommended Action
2419-xx	ECG/VGC ROM checksum test failed.	The following steps apply to error codes 2402-xx through 2456-xx:
2421-xx	ECG/VGC 640 × 200 graphics mode test failed.	1. Run the Configuration and Diagnostics utilities.
2422-xx	ECG/VGC 640 × 350 16 color set test failed.	2. Replace the monitor and retest.
2423-xx	ECG/VGC 640 × 350 64 color set test failed.	3. Replace the video board and retest (if applicable).
2424-xx	ECG/VGC monochrome text mode test failed.	4. Replace the system board.
2425-xx	ECG/VGC monochrome graphics mode test failed.	
2431-xx	640 × 480 graphics test failure.	
2432-xx	320 × 200 graphics (256 color mode) test failure.	
2448-xx	Advanced VGA Controller test failed.	
2451-xx	132-column Advanced VGA test failed.	
2456-xx	Advanced VGA 256 Color test failed.	
2458-xx	Advanced VGA BitBLT test.	The following steps apply to error codes 2458-xx through 2480-xx:
2468-xx	Advanced VGA DAC test.	1. Replace the video board and retest (if applicable).
2477-xx	Advanced VGA data path test.	2. Replace the system board and retest.
2478-xx	Advanced VGA BitBLT test.	
2480-xx	Advanced VGA Linedraw test.	

Table 2-12
Audio Test Error Codes

Error Code	Description	Recommended Action
3206-xx	Audio System Internal Error.	Replace the audio board and retest.

When Windows 95 is installed, changes to ESS sound device configuration do not take effect until the computer is restarted (turned off and on).

**Table 2-13
CD-ROM Test Error Codes**

Error Code	Description	Recommended Action
3301-xx	CD-ROM drive read test failed.	The following steps apply to error codes error codes 3301-xx through 3305-xx and 6600-xx through 6623-xx: 1. Replace the CD media and retest. 2. Verify that the speakers are connected. 3. Check and/or replace the power and signal cables and retest. 4. Replace the CD-ROM drive and retest.
3305-xx	CD-ROM drive seek test failed.	
6600-xx	ID test failed.	
6605-xx	Read test failed.	
6608-xx	Controller test failed.	
6623-xx	Random read test failed.	

**Table 2-14
Network Interface Test Error Codes**

Error Code	Description	Recommended Action
6000-xx	Network ID test failed.	The following steps apply to error codes 6000-xx through 6089-xx: 1. Turn computer off then on (cold boot) and run Computer Setup. 2. Verify test procedures. 3. Replace the network board. 4. Replace the system board.
6014-xx	Network configuration test failed.	
6016-xx	Network reset test failed.	
6028-xx	Network internal test failed.	
6029-xx	Network external test failed	
6054-xx	Network configuration test failed	
6056-xx	Network reset test failed	
6068-xx	Network internal test failed.	
6069-xx	Network external test failed.	
6089-xx	Network open test failed.	

**Table 2-15
Pointing Device Test Error Codes**

Error Code	Description	Recommended Action
8601-xx	Mouse test failed.	The following steps apply to error codes 8601-xx through 8602-xx: 1. Replace with a working mouse and retest. 2. Replace the system board and retest.
8602-xx	Interface test failed.	

2.4.1 SCSI Error Codes

The SCSI error codes are written in the format AABB-CC and can be determined by looking up the respective parts of the code in the three corresponding tables numbered 2-16, 2-17, and 2-18. AA (Table 2-16) identifies the drive type being tested. BB (Table 2-17) identifies the type of test. CC (Table 2-18) identifies the exact error received.

For example, if you received a diagnostic error code of 6523-05, you would look at Table 2-16 to identify the meaning of the first two numbers, 65. This indicates a hard drive problem. The second set of two numbers, 23, refers to a random read, as shown in Table 2-17. The last two numbers, 05, indicate a seek failure, as listed in Table 2-18. When you combine this information, you know that the diagnostics program was testing the random-read functioning of the hard drive and received a seek failure. The device is faulty and must be replaced.

Table 2-16
SCSI Device Names

65XX-XX	Hard Drive
66XX-XX	CD-ROM Drive
67XX-XX	Tape Drive

Table 2-17
SCSI Test Names

XX00-XX	ID
XX05-XX	Read
XX06-XX	SA/Media
XX23-XX	Random Read
XX28-XX	Media load/unload

Table 2-18
SCSI Test Error Codes

Error Code	Description	Recommended Action
XXXX-02	Drive not installed.	Check cable connections.
XXXX-03	Media not in drive.	Check for and install DATA CD or write-enabled tape in drive.
XXXX-05	Seek failure.	Replace the indicated device.
XXXX-06	Drive timed out.	Replace the indicated device.
XXXX-07	Drive busy.	Replace the indicated device.
XXXX-08	Drive already reserved.	Replace the indicated device.
XXXX-09	Unknown.	
XXXX-10	Unknown.	
XXXX-11	Media soft error.	Replace the indicated device.
XXXX-12	Drive not ready.	Replace the indicated device.
XXXX-13	Media error.	Replace the indicated device.
XXXX-14	Drive hardware error.	Replace the indicated device.
XXXX-15	Illegal drive command.	Replace the indicated device.
XXXX-16	Media was changed.	Replace the indicated device.
XXXX-17	Tape write-protected.	1. Disable write-protect on tape cartridge. 2. Replace tape drive.
XXXX-18	No data detected.	Replace the indicated device.
XXXX-21	Drive command aborted.	Replace the indicated device.
65XX-24	Media hard error.	1. Back up data and perform Surface Analysis to reallocate defect. 2. Replace drive.
66XX-24	Media hard error.	1. Replace current DATA CD with different DATA CD. 2. Replace drive.
67XX-24	Media hard error.	1. Ensure correct media type for this tape drive. 2. Replace current tape with new tape. 3. Replace tape drive.
XXXX-25	Unknown.	
XXXX-30	Controller timed out.	Replace the indicated device.
XXXX-31	Unrecoverable error.	Replace the indicated device.
XXXX-32	Controller/drive disconnected.	Replace the indicated device.
XXXX-33	Illegal controller command.	Replace the indicated device.
XXXX-34	Invalid SCSI bus phase.	Replace the indicated device.
XXXX-35	Invalid SCSI bus phase.	Replace the indicated device.
XXXX-36	Invalid SCSI bus phase.	Replace the indicated device.
XXXX-39	Error status from drive.	Replace the indicated device.
XXXX-40	Target timed out.	Replace the indicated device.

Continued

Table 2-18 *Continued*

Error Code	Description	Recommended Action
XXXX-41	SCSI bus stayed busy.	Replace the indicated device.
XXXX-42	ACK/REQ lines bad.	Replace the indicated device.
XXXX-43	ACK did not deassert.	Replace the indicated device.
XXXX-44	Parity error.	Replace the indicated device.
XXXX-50	Data pins bad.	Replace the indicated device.
XXXX-51	Data line 7 bad.	Replace the indicated device.
XXXX-52	MSG, C/D, and/or I/O lines bad.	Replace the indicated device.
XXXX-53	BSY never went busy.	Replace the indicated device.
XXXX-54	BSY stayed busy.	Replace the indicated device.
XXXX-60	Controller CONFIG-1 register bad.	Replace the indicated device.
XXXX-61	Controller CONFIG-2 register bad.	Replace the indicated device.
XXXX-65	Media not unloaded.	Replace the indicated device.
XXXX-90	Fan failure.	1. Ensure fan(s) connected. 2. Replace nonfunctional fan(s).
XXXX-91	Over Temperature.	1. Ensure proper air flow. 2. Perform required maintenance and cleaning.
XXXX-92	Side panel not installed.	If applicable, install side panel.
XXXX-99	Autoloader reported tapes not loaded properly.	1. Install tape(s) in autoloader tape drive according to test instructions. 2. Change autoloader magazine.

2.5 Troubleshooting Without Diagnostics

This section describes some simple, preliminary tests and guidelines for troubleshooting the computer without using the diagnostics.

2.5.1 Checklist for Solving Minor Problems

If you encounter some minor problem with the computer or a software application, go through the following checklist for possible solutions before running any of the diagnostic utilities:

- Is the computer connected to a working power outlet?
- Is the computer turned on and the power light illuminated?
- Are all cables connected properly and seated?
- Is the monitor turned on and the power light illuminated?
- If the monitor is dim, turn up the brightness and contrast controls of the monitor.
- Press and hold any key. If the system beeps, then the keyboard should be operating correctly.
- Are all of the necessary device drivers installed?
- Have all printer drivers been installed for each application?
- Is the *CONFIG.SYS* file correct?
- Is the *AUTOEXEC.BAT* file (MS-DOS) or *STARTUP.COM* file (OS/2) correct?
- Was a nonbootable diskette loaded in the diskette drive at powerup?
- Are all switch settings correct?
- Have all jumper settings been set as instructed by the configuration utility?
- Was Computer Setup run after installing options (memory, disk drives, expansion boards, etc.) and before installing industry standard architecture (ISA) boards?

2.5.2 Power Problems

This section identifies some quick checks for power-related problems.

Table 2-19
Solutions for Power Problems

Problem	Possible Solution
Computer will not turn on.	Ensure that the computer is connected to a power source. Cables to the external power source are unplugged. Ensure that cables connecting the computer and the external source are plugged in properly. A PCI or ISA card that has been installed is defective. Remove any adapter card that was just installed.
Computer does not automatically display the date and time.	The Real Time Clock (RTC) battery may need to be replaced. See Chapter 5 for replacement procedures.
Computer powered off automatically.	The unit temperature may have been exceeded. Check the fan for function and blockage.

2.5.3 Diskette Drive Problems

This section identifies some quick checks for diskette drive–related problems.

Table 2-20
Solutions for Diskette Drive Problems

Problem	Possible Solution
Diskette drive light stays on.	<ol style="list-style-type: none">1. Diskette can be damaged. Run CHKDSK or SCANDISK in Windows 3.1 on the diskette. In Windows 95, run ScanDisk. At the Start menu, highlight Programs, select Accessories, then select System Tools.2. Diskette could be installed incorrectly. Remove the diskette and reinsert.3. Software program may be damaged. Check the program diskettes.4. Drive cable is not properly connected. Reconnect drive cable.
Diskette drive cannot write to a diskette.	<ol style="list-style-type: none">1. Diskette is not formatted. Format the diskette.2. Diskette is write-protected. Either use another diskette that is not write-protected or disable the write protection on the diskette.3. Writing to the wrong drive. Check the drive letter in the path statement.4. Not enough space is left on the diskette. Use another diskette to write the information.5. Diskette write control is disabled. Check the security feature settings.
Diskette drive cannot read a diskette.	<ol style="list-style-type: none">1. Diskette is not formatted. Format the diskette.2. Using the wrong diskette type for the drive type. Use a diskette that is compatible with the drive.3. Reading the wrong drive. Check the drive letter in the path statement.4. Diskette is write-protected. Use another diskette or remove the write protection.5. Diskette drive has been disabled by Computer Setup. Run Computer Setup and enable the diskette drive.
A problem has occurred with a disk transaction	The directory structure is bad, or there is a problem with a file. Run CHKDSK. In Windows 95, run Scan Disk. At the Start menu, highlight Programs, select Accessories, then select System Tools.
Non-system disk message.	Remove the diskette from the drive.
Drive not found.	Check the cables for loose connections.

2.5.4 Display Problems

This section identifies some quick checks for display-related problems.

Table 2-21
Solutions for Display Problems

Problem	Possible Solution
Screen is blank.	<ol style="list-style-type: none">1. Monitor is not turned on and the monitor light is not on. Turn on the monitor and check that the monitor light is on.2. Screen save has been initiated. Press any key or move the mouse to light the screen.3. Check the cable connection from the monitor to the computer and check the electrical outlet.4. The brightness need adjusting. Adjust the brightness control.5. The QuickBlank feature has been enabled through Security Management. Run Computer Setup and disable the QuickBlank feature.6. The energy saver feature has been enabled. Hit any key or type the password.7. The RGB (Red, Green, Blue) input switch on the back of the monitor is incorrectly set. Set the monitor's input switch to 75 ohms and, if there is a sync switch, set it to External.8. If a fixed-sync monitor is used, be sure that the monitor can accept the same sweep rate as the resolution chosen.
Graphics colors are wrong.	<ol style="list-style-type: none">1. Ensure that the Red, Green, and Blue BNC cables are connected to the corresponding monitor connectors.2. Be sure the monitor's RGB inputs are set to 75 ohms.
Characters are dim.	<ol style="list-style-type: none">1. Adjust the monitor's brightness and contrast controls.2. Check that the video cable is securely connected to the graphics card and monitor.3. Set the RGB switch (and sync options, if available) to 75 ohms, with the sync set to External. Refer to the documentation included with the monitor.
Monitor does not function properly when used with the energy saver features.	Monitor without the energy saver feature is being used with energy saver features enabled. Disable the monitor energy saver feature.
Blurry display or requested resolution cannot be set.	If the graphics controller was upgraded, the correct display drivers may not be loaded. Install the correct display drivers on the diskette included in the upgrade kit.
The picture is broken up; it rolls, jitters, or blinks.	<ol style="list-style-type: none">1. Be sure the monitor cable is securely connected to the computer.2. In a 2-monitor system or if another monitor is in close proximity, be sure the monitors are not interfering with each other's magnetic field by moving them apart.
Garbled characters on the screen are mixed with text.	The ANSI.SYS driver is not in the <i>CONFIG.SYS</i> file. Add the ANSI.SYS driver to the <i>CONFIG.SYS</i> file by adding the following line: DEVICE = C:\CPQDOS\ANSI.SYS

Continued

Table 2-21 *Continued*

Problem	Possible Solution
Screen goes blank.	A screen blanking utility may be installed or energy saver features are enabled. Press any key or type password.
Monitor overheats.	There is not enough ventilation space for proper airflow. Leave at least 3-inches (7.6-cm) of ventilation space. Also, be sure there is nothing on top of the monitor to obstruct air flow.
Cursor will not move using the arrow keys on the numeric keypad.	The Num Lock key is on. Press the Num Lock key. The Num Lock light should not be on when you want to use the arrow keys.

2.5.5 Printer Problems


This section identifies some quick checks for printer-related problems.

Table 2-22
Solutions for Printer Problems

Problem	Possible Solution
Printer will not print.	<ol style="list-style-type: none">1. Printer is not turned on and online. Turn the printer on and make sure it is online.2. The correct printer drivers for the application are not installed. Install the correct printer drivers for the application.3. If the computer is on a network, you may not have made the connection to the printer. Make the proper network connections to the printer.
Printer will not turn on.	The cables may not be connected properly. Reconnect all cables and check the power cord and electrical outlet.
Prints garbled information.	<ol style="list-style-type: none">1. The correct printer drivers for the application are not installed. Install the correct printer driver for the application.2. The cables may not be connected properly. Reconnect all cables.
Printer is off line.	The printer may be out of paper. Check the paper tray and refill it if it is empty. Select online.

2.5.6 Hard Drive Problems

This section identifies some quick checks for hard drive-related problems.

-  The IntelliSafe hard drive stores prefailure information on certain parameters during drive operation. At some point, this information indicates that the drive should fail sometime in the future, even though it is currently working properly. When you run diagnostics, if there is any prefailure information stored on the drive, the computer will fail the hard drive diagnostics test. Proof of this test failure is required when returning a hard drive to Compaq as a failed hard drive.

The information provided by the diagnostics test includes: error code, system serial number, drive serial number, drive model, and drive firmware revision. Specific details of the drive failure are not included.

When you run the diagnostics, the test results are stored in a log. After completing the test, you can print this log to a local printer or save it to a file. Alternatively, before running the test, you can configure the test options to send the results to a local printer or file.

Solutions for some typical hard drive problems are presented in Table 2-23.

Table 2-23
Solutions for Hard Drive Problems

Problem	Possible Solution
Hard drive error occurs.	Hard disk has bad sectors or has failed. Use a utility to locate and block usage of bad sectors. If necessary, reformat the hard disk.
Disk transaction problem.	Either the directory structure is bad or there is a problem with a file. At the C:\> prompt, run SCANDISK to check for problems. If problems exist, run SCANDISK /AUTOFIX to correct the problems.
Drive not found.	<ol style="list-style-type: none"> 1. Cable could be loose. Check cable connections. 2. The system may not have automatically recognized a newly-installed device. If Windows 3.1 is installed, run Computer Setup and identify the new device. If Windows 95 is installed, run Device Manager and identify the device. 3. If the drive is a secondary drive that has just been installed on the same controller as the primary drive, verify that the jumpers for both drives are set correctly.
Nonsystem disk message.	<ol style="list-style-type: none"> 1. The system is trying to start from a diskette that is not bootable. Remove the diskette from the diskette drive. 2. The system is trying to start from the hard drive but the hard disk has been damaged. Insert a bootable diskette into the diskette drive and restart the computer with Ctrl+Alt+Del. 3. Diskette boot has been disabled in Computer Setup. Run Computer Setup and enable diskette boot.
Hard drive operation seems slow.	<p>The hard disk files may be fragmented.</p> <p>At the C:\> prompt, run SCANDISK to check for problems. If problems exist, run SCANDISK /F to correct the problems. If a large number of lost allocation units is found, run the MS-DOS defragmentation program DEFRAG. See the <i>Microsoft Windows & MS-DOS 6.2 User's Guide</i> for more information.</p> <p>Alternatively, at the C:\> prompt, run SCANDISK to check for problems. If problems exist, run SCANDISK /AUTOFIX to correct the problems. If a large number of lost allocation units is found, run the MS-DOS defragmentation program DEFRAG. Type HELP SCANDISK for more information.</p>

2.5.7 Hardware Installation Problems

This section identifies some quick checks for hardware problems.

Table 2-24
Solutions for Hardware Installation Problems

Problem	Possible Solutions
A new device is not recognized as part of the computer system.	<ol style="list-style-type: none">1. The Computer Setup utility has not been run to configure the new device. Run the Computer Setup utility.2. When the system advised you of changes to the configuration, you did not accept them. Reboot the computer and follow the instructions for accepting the changes.3. The system may not have automatically recognized the new device. If Windows 3.1 is installed, run Computer Setup and identify the new device. If Windows 95 is installed, run Device Manager and identify the device.4. A Plug and Play board may not automatically configure when added if the default configuration conflicts with other devices. Use Computer Setup (Windows 3.1 installed) or Device Manager (Windows 95 installed) to deselect the automatic settings for the board and choose a basic configuration that doesn't cause a resource conflict.5. The cables for the new external device are loose or the power cables are unplugged. Check all cables.6. The power switch for the new external device is not turned on. Turn off the computer, turn on the external device, and then turn the computer on to integrate the new device with the computer.7. If the drive is a secondary drive that has just been installed on the same controller as the primary drive, verify that the jumpers for both drives are set correctly.
The computer supports plug and play, but the hardware configuration settings in Computer Setup do not match the settings in Windows 95 Device Manager.	<p>In Windows 95, when onboard serial devices are assigned to ports other than COM1 or COM2, the configuration is saved statically in CMOS. When the system is rebooted, the ROM configures the device to the static setting; when Windows 95 loads, it configures the device to the configuration set via Device Manager. In such cases, the configuration shown when F10 Setup is run does not match what was set up via Device Manager.</p> <p>If these devices must be configured a certain way before Windows 95 loads, then the serial port devices on the system should only be configured to COM1 or COM2 resources. If the system has two serial devices plus a modem, then the first serial device can be COM1 or COM2 or disabled, the modem can be COM1 or COM2 or disabled, and the second serial device can be COM4 or disabled.</p>

2.5.8 CD-ROM Drive Problems

This section identifies some quick checks for CD-ROM–drive-related problems.

Table 2-25
CD-ROM Drive Problems

Problem	Possible Solution
Cannot read compact disc.	<ol style="list-style-type: none">1. CD is not properly seated in the drive. Eject the CD, correctly seat it in the drive, then reload.2. CD has been loaded upside down. Eject the CD, turn it over, then reload.
System will not boot from CD-ROM drive.	<ol style="list-style-type: none">1. The CD-ROM boot is not enabled through the Computer Setup utility. Run the Computer Setup utility and set the drive priorities.2. Ensure that drive cabling and jumpers are set correctly. To boot a SCSI drive, the drive ID number must be set to 0.
Cannot eject compact disc.	CD is not properly seated in the drive. Turn off the computer and insert a thin metal rod into the emergency eject hole and push firmly (a straightened paper clip can be used). Slowly pull the tray out from the drive until the tray is fully extended, then remove the CD.
CD-ROM device is not detected; driver is not loaded.	CD-ROM drive is not connected properly. Open the computer and check to see that the drive cable is connected properly.

2.5.9 Memory Problems

This section identifies some quick checks for memory-related problems.

Table 2-26
Memory Problems

Problem	Possible Solution
Out of Memory error.	<ol style="list-style-type: none">1. In Windows 3.1 and Windows NT, check the CONFIG.SYS file for the present memory configuration, and edit the file using a text editor. In Windows 95, use the Device Manager to check memory configuration.2. The computer has run out of memory to run the application. Check the application documentation to determine the memory requirements.
Memory count during POST is wrong.	The memory modules may not be installed correctly. Check that the memory modules have been installed correctly and that mixed EDO and FPM DRAM are in the correct bank, then run the Configuration utility. (If the system contains mixed EDO and FPM DRAMs, the EDO pair is one bank and the FPM pair is another bank.)
Insufficient memory error during operation	<ol style="list-style-type: none">1. Too many Terminate and Stay Resident programs (TSRs) are installed. Delete any unnecessary TSRs.2. The computer has run out of memory for the application. Check the memory requirements for the application or add more memory to the computer.

2.5.10 SCSI Problems

Some common causes and solutions for SCSI device problems are listed in the following table.

**Table 2-27
SCSI Problems**

Problem	Cause	Solution
System with IDE and SCSI drives will not boot from SCSI hard drive	The IDE drive is not disabled through the Configuration utility.	Run the Configuration utility and disable the primary IDE drive.
System without an IDE drive will not boot from a SCSI drive	The SCSI drive is not configured correctly.	Ensure that drive cabling and jumpers are set correctly. To boot a SCSI drive, the drive ID number must be set to 0.

2.5.11 Network Problems

Some common causes and solutions for network problems are listed in the following table. These guidelines do not discuss the process of debugging network cabling.

**Table 2-28
Network Problems**

Problem	Cause	Solution
System does not detect a network controller.	Possible I/O address conflict with another expansion board.	Factory default is 300h to 30Fh for Ethernet. Either remove and reconfigure the conflicting expansion board, or reconfigure the network controller. If the address is changed, ensure that the drive parameters match the new I/O address for the network controller.
System Configuration utility reports unprogrammed EPROM.	<ol style="list-style-type: none"> 1. Possible I/O address conflict with another expansion board. 2. The network controller is defective. 3. Network drivers are loaded. 	<ol style="list-style-type: none"> 1. Factory default is 300h to 30Fh for Ethernet. Either remove and reconfigure the conflicting expansion board, or reconfigure the network controller. If the address is changed, ensure that the drive parameters match the new I/O address for the network controller. 2. Replace the controller or the system board. 3. Boot the computer without the network drivers, using a system boot diskette, and reconfigure the network controller.
Diagnostics reports a failure.	<ol style="list-style-type: none"> 1. Possible I/O address conflict with another expansion board. 2. The cable is not securely connected. 3. The cable is attached to the incorrect connector. 4. There is a problem with the cable or a device at the other end of the cable. 5. The network controller is defective. 6. Network controller interrupt or memory overlaps the interrupt or memory of an expansion board. 	<ol style="list-style-type: none"> 1. Factory default is 300h to 30Fh for Ethernet. Either remove and reconfigure the conflicting expansion board, or reconfigure the network controller. If the address is changed, ensure that the drive parameters match the new I/O address for the network controller. 2. Ensure that the cable is securely attached to the network connector and that the other end of the cable is securely attached to the correct device. 3. Ensure that the cable is attached to the correct connector. 4. Ensure that the cable and device at the other end are operating correctly. 5. Replace the controller or the system board. 6. Run Computer Setup and modify the network controller memory value.

Continued

Table 2-28 *Continued*

Problem	Cause	Solution
Diagnostics passes, but the computer does not communicate with the network.	<ol style="list-style-type: none"> 1. Network drivers are not loaded, or driver parameters do not match current configuration. 2. The network controller is not configured for this computer. 3. The network controller interrupt or memory overlaps the interrupt or memory of an expansion board. 	<ol style="list-style-type: none"> 1. Make sure the network drivers are loaded and that the driver parameters match the configuration of the network controller. 2. In Windows 3.1, run Network Setup found in the Control Center, and reconfigure the network controller and/or driver. Ensure that the driver parameters match the new configuration. In Windows 95 or Windows NT, select the Network icon at the Control Panel. Reconfigure the driver if necessary, using the Network Setup found in the Control Center. 3. Run Computer Setup and modify the network controller memory value.
Network controller stopped working when an expansion board was added to the computer.	<ol style="list-style-type: none"> 1. Network drivers are not loaded or driver parameters do not match the current configuration. 2. The cable is not securely connected. 3. The network controller interrupt or memory overlaps the interrupt or memory of another expansion board. 4. The network controller require drivers. 5. The files containing the network drivers are corrupted. 	<ol style="list-style-type: none"> 1. Make sure that the network drivers are loaded and that the driver parameters match the configuration of the network controller using Network Setup found in the Control Center. 2. Ensure that the cable is securely attached to the network connector and that the other end of the cable is securely attached to the correct device. 3. Run Computer Setup and modify the network controller memory value. 4. Verify that the drivers were not accidentally deleted when the drivers for a new expansion board were installed. 5. Reinstall the network drivers, using the backup diskettes and then run Computer Setup.
Network controller stopped working without apparent cause.	<ol style="list-style-type: none"> 1. The files containing the network drivers are corrupted. 2. The cable is not securely connected. 3. The network controller is defective. 	<ol style="list-style-type: none"> 1. Reinstall the network drivers using the backup diskettes and then run Computer Setup. 2. Ensure that the cable is securely attached to the network connector and that the other end of the cable is securely attached to the correct device. 3. Replace the network controller or system board.

2.5.12 Troubleshooting Using Compaq Intelligent Manageability Features

A Local Alert pop-up dialog box notifies you of an impending or actual hardware failure. If the computer is connected to a network and the Compaq Insight Management Desktop Agents are installed and configured, an SNMP trap (message) is sent to the specified SNMP-compliant management application.

The Local Alert message also tells you the steps you need to take prior to a hardware failure to avoid loss of data and damage to the computer. The system administrator can create a customized action message that might include contact telephone or pager numbers.

To close the Local Alert Pop-Up Dialog, click the Close button. To retrieve fault information after closing the dialog, run Compaq Insight Personal Edition.

Table 2-29
IntelliSafe SMART Hard Drive Alert Message

Message	Possible Solution
IntelliSafe SMART Hard Drive detects an imminent failure. Immediate action is recommended since data stored on drives xx may be lost.	Make note of the drive and system information provided below. Save the critical data on the affected hard drive(s). Contact the system administrator.

chapter 3

ILLUSTRATED PARTS CATALOG

This chapter provides an illustrated parts breakdown and a reference for spare parts for the Compaq Deskpro 2000 Series of Personal Computers.



Figure 3-1. Compaq Deskpro 2000 Series Personal Computer

3.1 System Unit

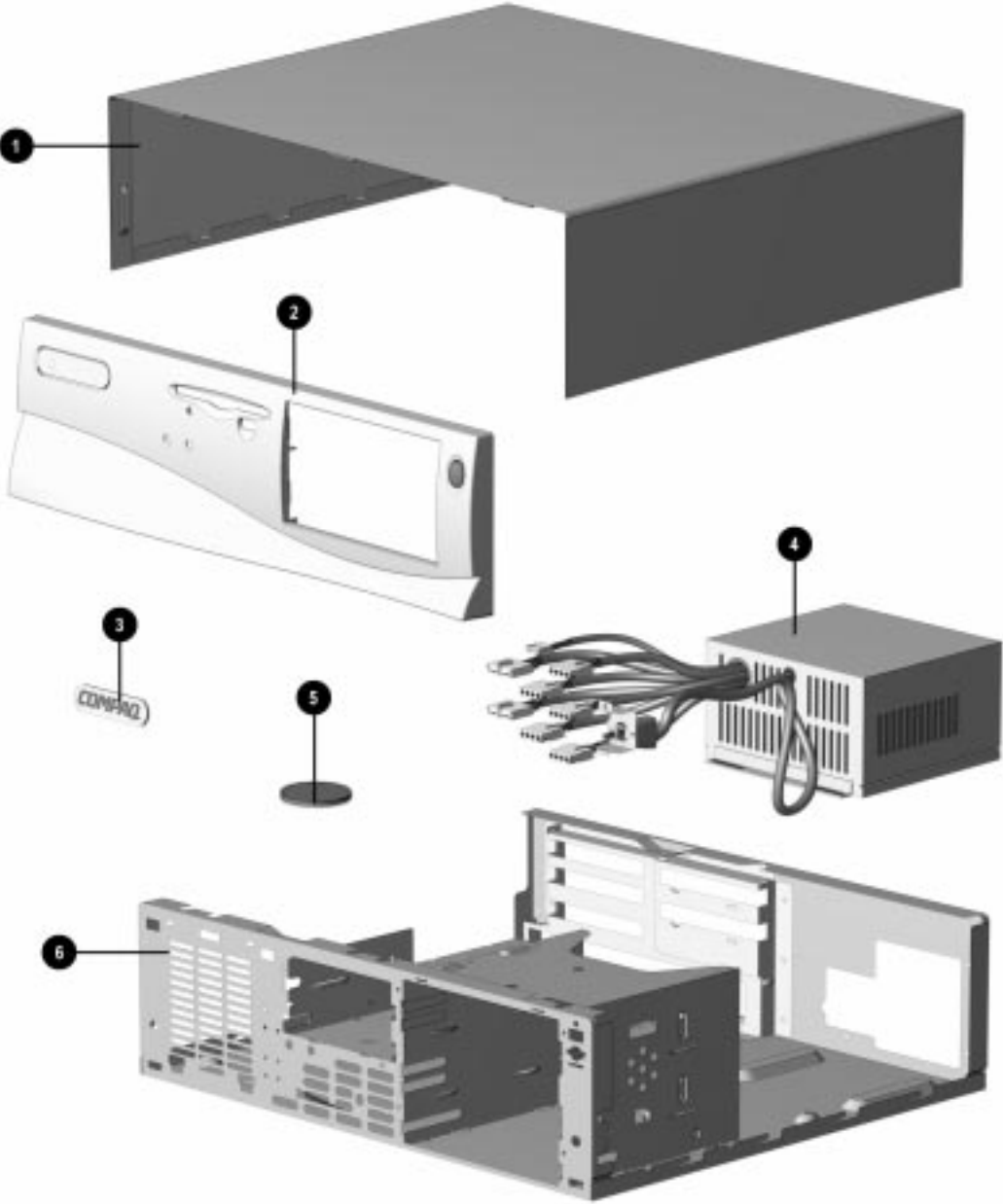


Figure 3-2. System Unit, Desktop

Table 3-1
System Unit Spare Parts: Desktop

Description	Spare Part Number	Warranty Tier
1. Hood, desktop	243089-001	A
2. Front bezel. Includes power switch cap and blank bezel (Order logo separately)	243088-001	A
3. Logo Kit	247525-001	A
4. Power supply, 200W (Includes fan, power switch, power switch mounting bracket)	242908-001	A
5. Foot, rubber (4 each, desktops and minitowers)	141332-001	A
6. Chassis Assembly (Base pan), desktop (shown for reference only)		

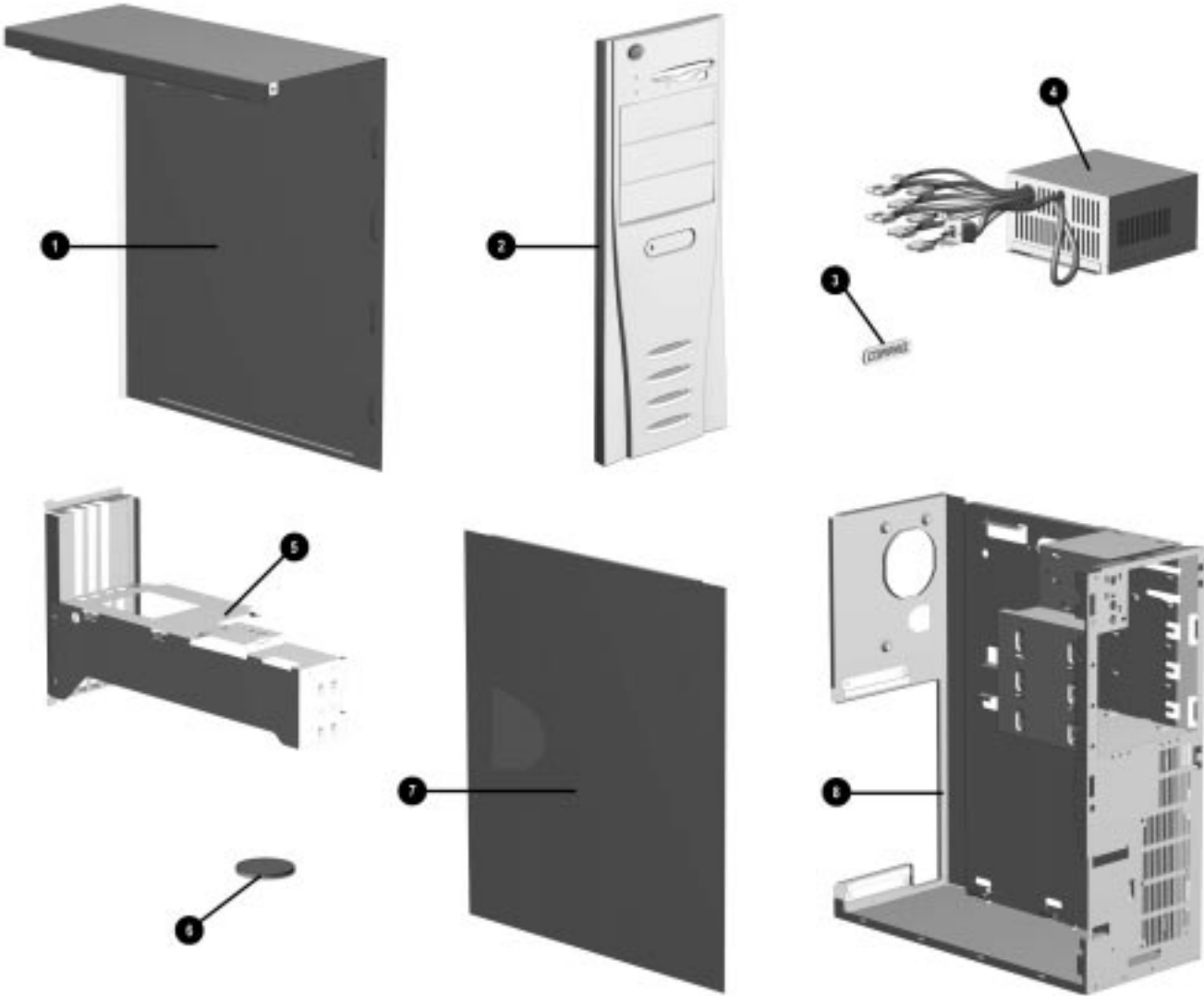


Figure 3-3. System Unit, Minitower

Table 3-2
System Unit Spare Parts: Minitower

Description	Spare Part Number	Warranty Tier
1. "J" Hood (minitower)	185972-001	A
2. Front bezel. Includes power switch cap and blank bezel (Order logo separately)	243096-001	A
3. Logo Kit (includes logos for all models)	247525-001	A
4. Power supply, 200W (Includes fan, power switch, power switch mounting bracket)	242908-001	A
5. Brace, riser	243190-001	A
6. Foot, rubber (4 each, desktops and minitowers)	141332-001	A
7. Access Panel, minitower	185971-001	A
8. Chassis Assembly, minitower (shown for reference only)		

3.2 Mass Storage Devices

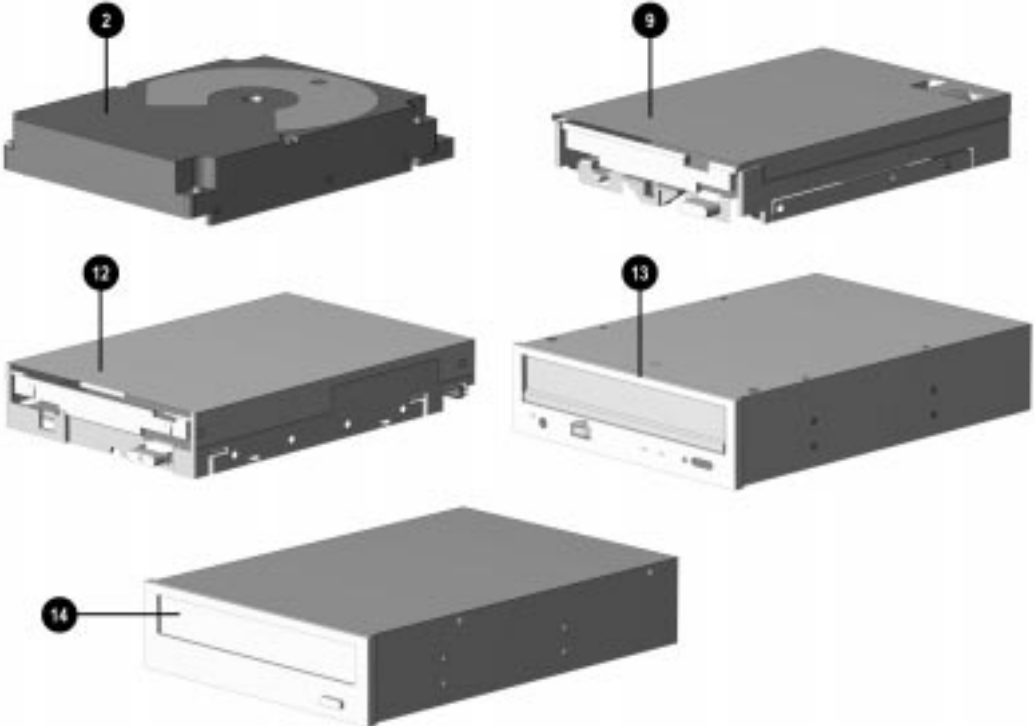


Figure 3-4. Mass Storage Devices

**Table 3-3
Mass Storage Devices**

Description	Spare Part Number	Warranty Tier
1. 630-MB IDE hard drive*	173114-001	A
2. 1.08-GB IDE hard drive	243043-001	A
3. 1.2-GB hard drive*	242990-001	A
4. 1.62-GB hard drive*	247411-001	A
5. 2.0-GB hard drive*	225521-001	A
6. 2.5-GB hard drive*	242992-001	A
7. 2.1-GB Ultra SCSI hard drive*	247409-001	A
8. 1.0-GB SCSI-2 hard drive*	192799-001	A
9. 1.0 -GB Ultra - SCSI hard drive`	247410-001	A
10. Diskette drive (3.5-inch, 1.44-MB, 3-mode, 1/3-height w/o bracket and bezel)	160788-201	A
11. Diskette drive (5.25-inch, 1.2-MB, 1/2-height)*	141367-201	A
12. LS-120 Drive (3.5-inch, 120-/1.44-MB)	263709-001	A
13. PD-CD Drive (650-MB, SCSI)	184691-201	A
14. CD-ROM Drive, Compaq 8X IDE	185916-201	A
15. 340/680-MB tape drive w/ compression*	187658-001	A
16. 1.2-GB ACA tape drive, QIC*	199615-001	A
17. 2/8-GB DAT tape drive w/compression*	142074-201	A
18. Tape cartridge, 1.2-GB*	199625-001	D
19. Tape cartridge, DAT, 1.3-GB*	131167-001	D
20. Tape cartridge, DAT, 2.0-GB*	131148-001	D
21. Tape cartridge, 4.06-GB, DDS2*	199496-001	D
22. Tape cartridge, 340/680-MB*	184299-001	D
23. PD-CD 650-MB Media*	186075-001	D
24. LS-120 Media*	186076-001	D

*Not shown

3.3 Cables

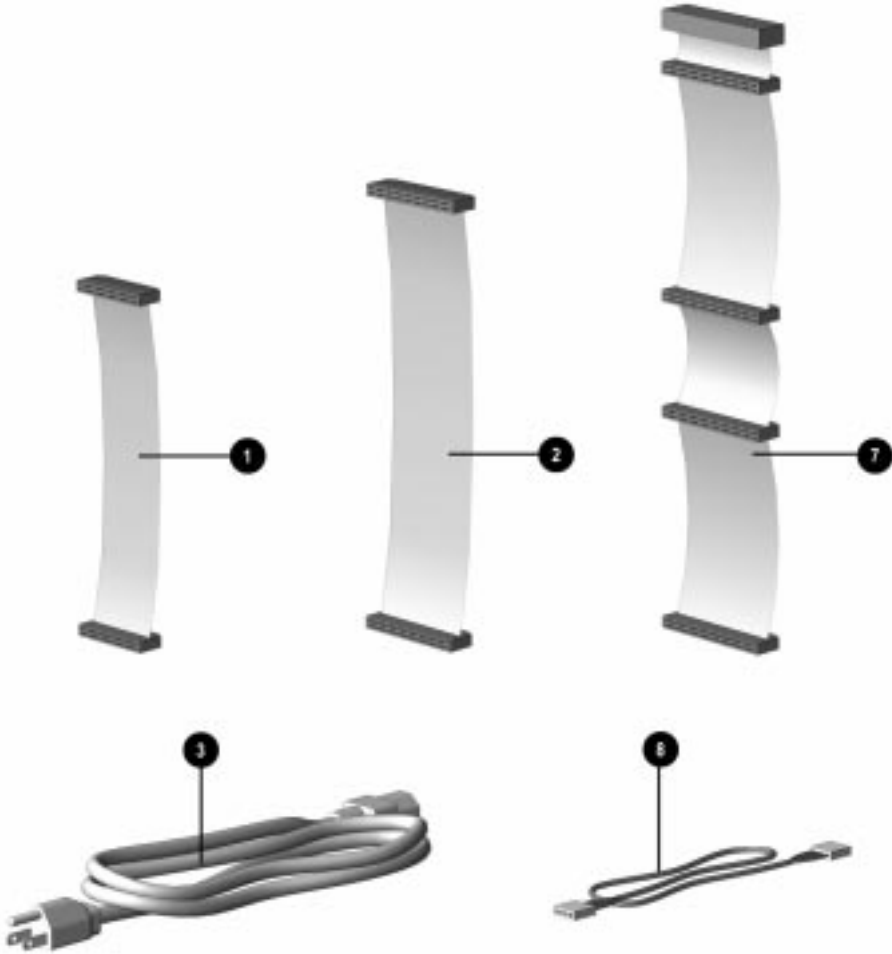


Figure 3-5. Cables

**Table 3-4
Cables**

Description	Spare Part Number	Warranty Tier
1. Cable, diskette drive	243084-001	A
2. Cable, IDE CD-ROM/hard drive	243085-001	A
3. Power cord, AC, Gray (US, Canada)	121258-001	A
4. Cable assembly, LED (desktops)*	243095-001	A
5. Cable assembly, LED (minitowers)*	243110-001	A
6. Cable, Dual IDE*	247568-001	A
7. Cable, Ultra SCSI	148259-001	A
8. Cable, CD-ROM audio	171109-001	A

*Not shown

3.4 Standard and Optional Boards

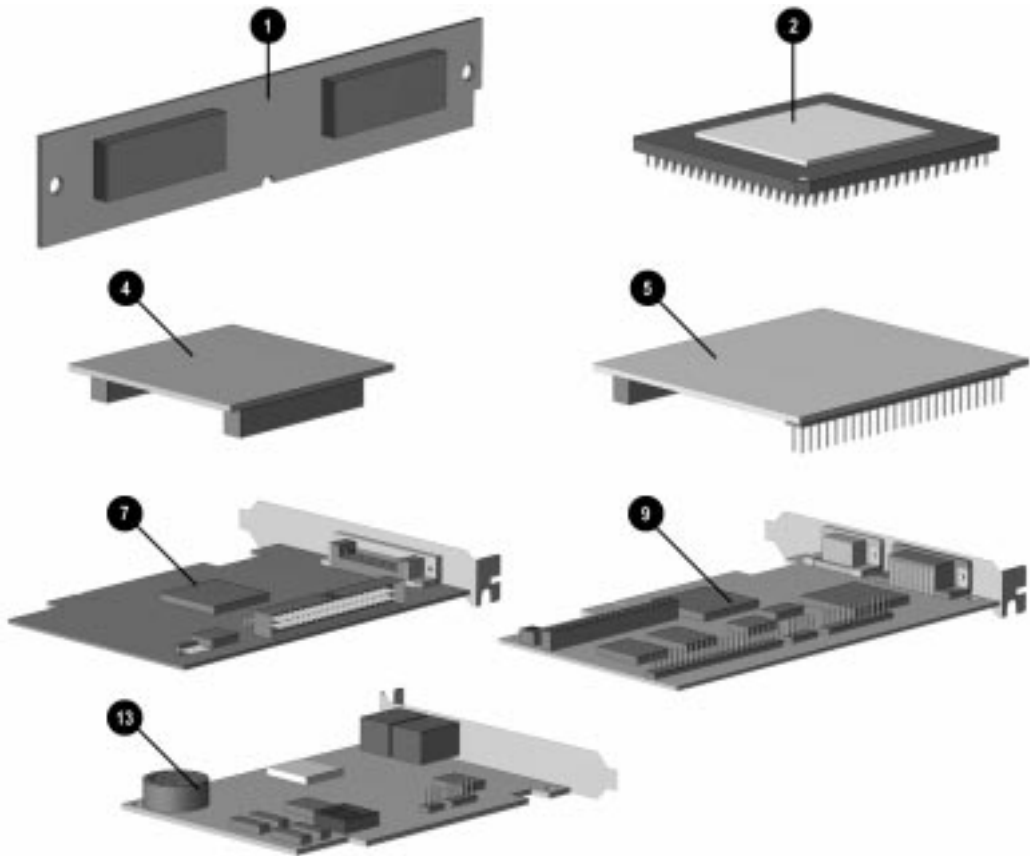


Figure 3-6. Standard and Optional Boards

**Table 3-5
Standard and Optional Boards**

Description	Spare Part Number	Warranty Tier
1. Memory module (EDO SIMM, 4-MB/60ns/SnPb)	236512-001	A
1. Memory module (EDO SIMM, 8-MB/60ns/SnPb)*	236513-001	A
1. Memory module (EDO SIMM, 16-MB/60ns/SnPb)*	243115-001	A
1. Memory module (EDO SIMM, 32-MB/60ns/SnPb)*	243116-001	A
2. Processor, P5/100 MHz	213113-001	A
2. Processor, P5/120 MHz*	213125-001	A
2. Processor, P5/133 MHz*	243133-001	A
2. Processor, P5/166 MHz*	243134-001	A
2. Processor, P5/200 MHz*	243118-001	A
3. Processor, P6/180 MHz*	234536-001	A
3. Processor, P6/200 MHz*	210998-001	A
4. DRAM, 1-MB EDO, for Cirrus Logic 5436 and 5446	213859-001	A
5. WRAM, 2-MB for Millennium Graphics*	223339-001	A
5. WRAM, 6-MB for Millennium Graphics	223340-001	A
6. Controller, Plug and Play SCSI-2, ISA*	133880-001	A
7. Controller, PCI Ultra SCSI, Plug and Play	247399-001	A
8. Controller, Graphics (PCI, CL-GD5446)*	247425-001	A
9. Controller, Matrox MGA Millennium Graphics	243136-001	A
10. Controller, 16/4 PCI Token Ring*	199764-001	A
11. Controller, 10/100TX PCI UTP*	169849-001	A
12. Controller, 10T PCI UTP*	242501-001	A
13. Modem, 28.8 DataFax Modem (US)	259214-002	A
14. Compaq Business Pro Audio*	247428-001	A
15. Controller, NetFlex ENET/ISA*	147220-001	A
16. Serial/Parallel Interface Board*	106886-002	A

*Not shown

continued

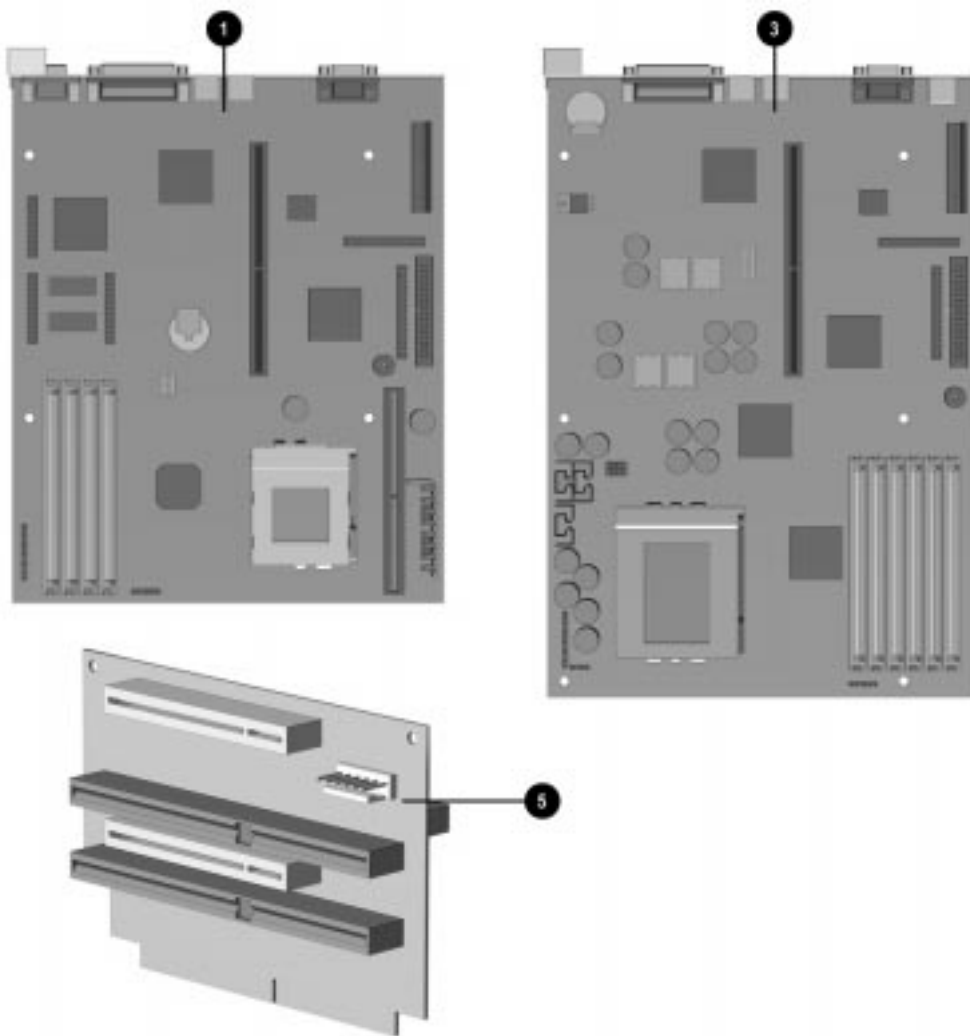


Figure 3-7. System and Riser Boards

Table 3-5 continued

Description	Spare Part Number	Warranty Tier
1. System board, P5-based, w/ I/O panel, desktop †	243048-001	A
2. System board, P5-based, w/ tray, minitower *†	243099-001	A
3. System board, P6-based, w/ I/O panel, desktop †	243049-001	A
4. System board, P6-based, w/ tray, minitower* †	243111-001	A
5. Riser board, desktop	243056-001	A
6. Riser board, minitower*	243057-001	A
7. Cache memory (L2/256Kb)*	243117-001	A

*Not shown

†Shipped without microprocessor or memory

- 1. Desktop system boards are spared with the I/O panel attached.
- 2. Minitower system boards are spare mounted in the system board tray.

3.5 Keyboards

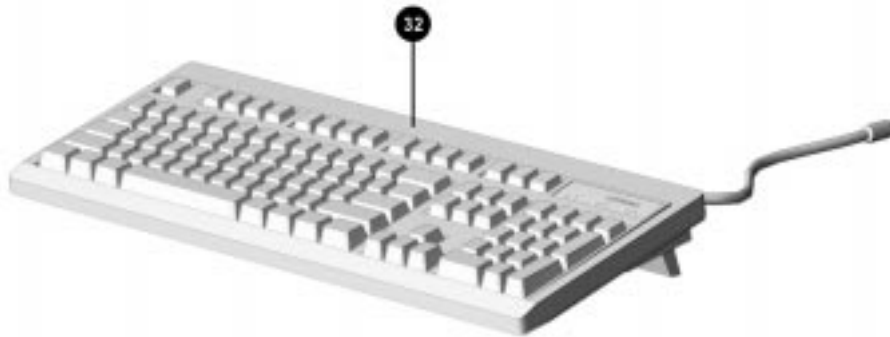


Figure 3-8. Keyboard

Table 3-6
Keyboards

Description	Spare Part Number	Warranty Tier
1. Keyboard, (Arabic)*	235496-136	A
2. Keyboard, (Belgian)*	235496-118	A
3. Keyboard, (Brazilian)*	235496-135	A
4. Keyboard, (BHCSY)*	235496-120	A
5. Keyboard, (Canadian Government)*	235496-131	A
6. Keyboard, (Chinese)*	235496-132	A
7. Keyboard, (New Czech)*	235496-138	A
8. Keyboard, (Danish)*	235496-108	A
9. Keyboard, (Finnish)*	235496-137	A
10. Keyboard, (French)*	235496-105	A
11. Keyboard, (French Canadian)*	235496-112	A
12. Keyboard, (German)*	235496-104	A
13. Keyboard, (Greek)*	235496-115	A
14. Keyboard, (Hungarian)*	235496-121	A
15. Keyboard, (Italian)*	235496-106	A
16. Keyboard, (Japanese)*	235496-119	A
17. Keyboard, (Hanguel/Korean)*	235496-133	A
18. Keyboard, (International)*	235496-102	A
19. Keyboard, (Latin American Spanish)*	235496-116	A
20. Keyboard, (Norwegian)*	235496-109	A

* Not shown

continued

Table 3-6 *Continued*

Description	Spare Part Number	Warranty Tier
21. Keyboard, (Polish)*	235496-122	A
22. Keyboard, (Portuguese)*	235496-113	A
23. Keyboard, (Russian)*	235496-124	A
24. Keyboard, (Slovakian)*	235496-123	A
25. Keyboard, (Spanish)*	235496-107	A
26. Keyboard, (Swedish)*	235496-110	A
27. Keyboard, (Swiss)*	235496-111	A
28. Keyboard, (Taiwanese)*	235496-134	A
20. Keyboard, (Thai)*	235496-130	A
30. Keyboard, (Turkish)*	235496-114	A
31. Keyboard, (UK)*	235496-103	A
32. Keyboard, (US)	235496-101	A
33. Keyboard, Scanner, (Belgian/French)*	185288-318	A
34. Keyboard, Scanner, (Brazilian)*	185388-335	A
35. Keyboard, Scanner, (French)*	185288-305	A
36. Keyboard, Scanner, (German)*	185288-304	A
37. Keyboard, Scanner (International)*	185288-302	A
38. Keyboard, Scanner, (Italian)*	185288-306	A
39. Keyboard, Scanner, (Japanese)*	185288-319	A
40. Keyboard, Scanner, (Latin America Spanish)*	185288-316	A
41. Keyboard, Scanner, (Spanish)*	185288-307	A
42. Keyboard, Scanner, (Swiss, German, French, Italian)*	185288-311	A
43. Keyboard, Scanner, (UK)*	185288-303	A
44. Keyboard, Scanner (US)*	185288-301	A
45. Keyboard, ECH, Erase-Eaze, Windows, (Arabic)*	247431-136	A
46. Keyboard, ECH, Erase-Eaze, Windows, (Belgian)*	247431-118	A
47. Keyboard, ECH, Erase-Eaze, Windows, (BHCSY)*	247431-120	A
48. Keyboard, ECH, Erase-Eaze, Windows, (Chinese)*	247431-132	A
49. Keyboard, ECH, Erase-Eaze, Windows, (New Czech)*	247431-138	A
50. Keyboard, ECH, Erase-Eaze, Windows, (Danish)*	247431-108	A
51. Keyboard, ECH, Erase-Eaze, Windows, (Finnish)*	247431-137	A
52. Keyboard, ECH, Erase-Eaze, Windows, (French)*	247431-105	A
53. Keyboard, ECH, Erase-Eaze, Windows, (French Canadian)*	247431-112	A
54. Keyboard, ECH, Erase-Eaze, Windows, (German)*	247431-104	A
55. Keyboard, ECH, Erase-Eaze, Windows, (Greek)*	247431-115	A

*Not shown

continued

Table 3-6 *Continued*

Description	Spare Part Number	Warranty Tier
56. Keyboard, ECH, Erase-Eaze, Windows, (Hunguel)*	247431-133	A
57. Keyboard, ECH, Erase-Eaze, Windows, (Hungarian)*	247431-121	A
58. Keyboard, ECH, Erase-Eaze, Windows, (International)*	247431-102	A
59. Keyboard, ECH, Erase-Eaze, Windows, (Italian)*	247431-106	A
60. Keyboard, ECH, Erase-Eaze, Windows, (Latin American Spanish)*	247431-116	A
61. Keyboard, ECH, Erase-Eaze, Windows, (North America)*	247431-101	A
62. Keyboard, ECH, Erase-Eaze, Windows, (Norwegian)*	247431-109	A
63. Keyboard, ECH, Erase-Eaze, Windows, (Polish)*	247431-122	A
64. Keyboard, ECH, Erase-Eaze, Windows, (Portuguese)*	247431-113	A
65. Keyboard, ECH, Erase-Eaze, Windows, (Russian)*	247431-124	A
66. Keyboard, ECH, Erase-Eaze, Windows, (Slovakian)*	247431-123	A
67. Keyboard, ECH, Erase-Eaze, Windows, (Spanish)*	247431-107	A
68. Keyboard, ECH, Erase-Eaze, Windows, (Swedish)*	247431-110	A
69. Keyboard, ECH, Erase-Eaze, Windows, (Swiss)*	247431-111	A
70. Keyboard, ECH, Erase-Eaze, Windows, (Taiwanese)*	247431-134	A
71. Keyboard, ECH, Erase-Eaze, Windows, (Thai)*	247431-130	A
72. Keyboard, ECH, Erase-Eaze, Windows, (Turkish)*	247431-114	A
73. Keyboard, ECH, Erase-Eaze, Windows, (UK)*	247431-103	A

* Not shown

3.6 Monitors

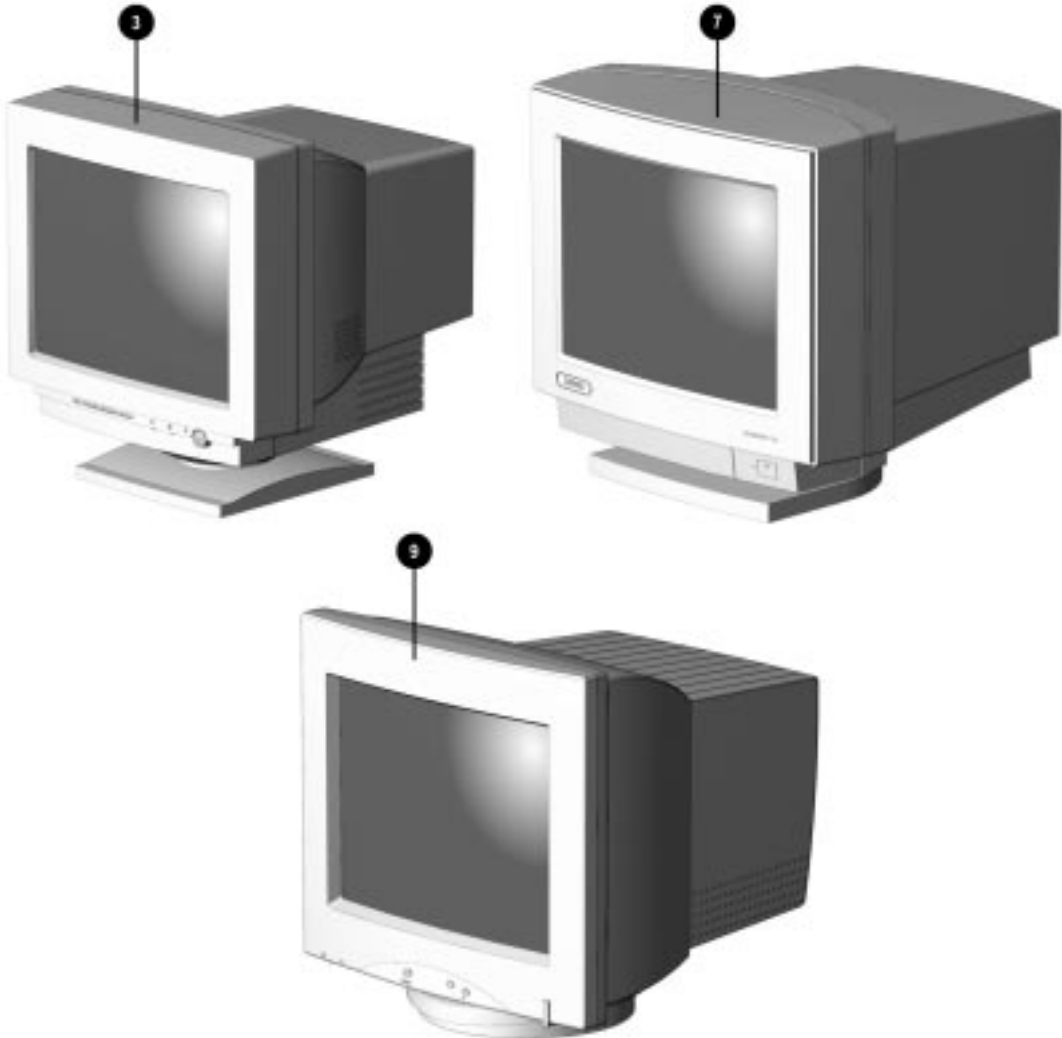


Figure 3-9. Monitors

**Table 3-7
Monitors**

Description	Spare Part Number	Warranty Tier
1. VGA 14" Monochrome Monitor (NA, MPR)*	194962-001	A
1. VGA 14" Monochrome Monitor (NH, MPR)*	194962-002	A
1. VGA 14" Monochrome Monitor (SH, MPR)*	194962-003	A
1. VGA 14" Monochrome Monitor (GSA, MPR)*	194962-004	A
2. 1024 14" Color Monitor, AssetControl (NH)*	141568-602	A
2. 1024 14" Color Monitor, AssetControl (SH)*	141568-603	A
2. 1024 14" Color Monitor, AssetControl (GSA)*	141568-604	A
3. Compaq 140 VGA Color Monitor, Low Emissions (14", NA, MPR)	210507-601	A
3. Compaq 140 VGA Color Monitor, Low Emissions (14", NH, MPR)*	210507-602	A
3. Compaq 140 VGA Color Monitor, Low Emissions (14", SH, MPR)*	210507-603	A
3. Compaq 140 VGA Color Monitor, Low Emissions (14", GSA, MPR)*	210507-604	A
3. Compaq 140 VGA Color Monitor (14", NH, POL)*	210507-606	A
4. Compaq 150 Color Monitor (15", NA, MPR)*	210510-601	A
4. Compaq 150 Color Monitor (15", NH, MPR)*	210510-602	A
4. Compaq 150 Color Monitor (15", SH, MPR)	210510-603	A
4. Compaq 150 Color Monitor (15", GSA, MPR)*	210510-604	A
4. Compaq 150 Color Monitor (15", NH, POL)*	210510-606	A
5. 151 FS Color Monitor, Low Emissions/AssetControl (NA, 444)*	147265-601	A
5. 151 FS Color Monitor, Low Emissions/AssetControl (TCO, NH, 444)*	147265-602	A
5. 151 FS Color Monitor, Low Emissions/AssetControl (SH, 444)*	147265-603	A
5. 151 FS Color Monitor, Low Emissions/AssetControl (GSA, 444)*	147265-604	A
6. 171 FS Color Monitor, Low Emissions/AssetControl (NA, 491)*	190916-601	A
6. 171 FS Color Monitor, Low Emissions/AssetControl (TCO, NH, 491)*	190916-602	A
6. 171 FS Color Monitor, Low Emissions/AssetControl (SH, 491)*	190916-603	A
6. 171 FS Color Monitor, Low Emissions/AssetControl (GSA, 491)*	190916-604	A
7. QVision 172 Color Monitor (NA)	143547-602	A
7. QVision 172 Color Monitor (SH)*	143547-603	A
7. QVision 172 Color Monitor (NH, TCO)*	143547-604	A

*Not shown

Continued

Table 3-7 *Continued*

Description	Spare Part Number	Warranty Tier
8. QVision 210 Color Monitor (NA)*	210407-601	A
8. QVision 210 Color Monitor (NH, TCO)*	210407-602	A
8. QVision 210 Color Monitor (SH)*	210407-603	A
9. Compaq V70 Color Monitor (17", MPR, NA)	255609-001	A
9. Compaq V70 Color Monitor (17", MPR, GSA)*	255609-004	A
9. Compaq V70 Color Monitor (17", TCO95, UPS, EUR)*	255638-021	A
9. Compaq V70 Color Monitor (17", MPR, UPS, INTL, SH)*	225638-B21	A
9. Compaq V70 Color Monitor (17", MPR, UPS, INTL, NH)*	225638-B22	A
9. Compaq V70 Color Monitor (17", TCO95, UPS, INTL, SH)*	225638-B23	A
10. Compaq 140 International Europe Only*	210452-602	A

*Not shown

3.7 Miscellaneous Hardware Kit

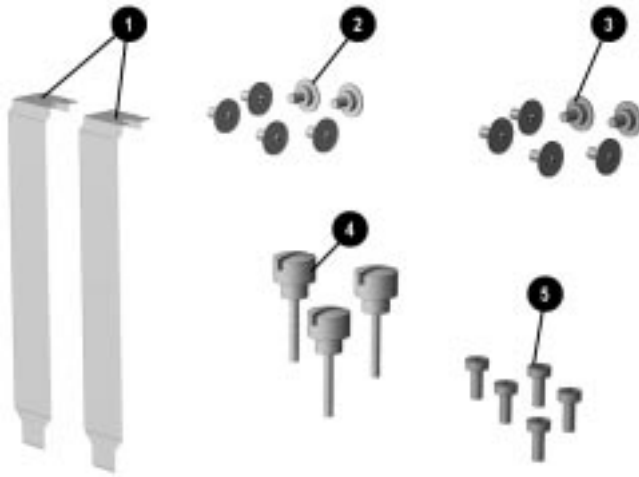


Figure 3-10. Miscellaneous Hardware Kit

Table 3-8
Miscellaneous Hardware Kit

Description	Spare Part Number	Warranty Tier
Miscellaneous hardware kit. Includes:	243087-001	D
1. Slot cover (2 each)		
2. Screw, 6-32, TT, wafer head (6 each)		
3. Screw, M3, TT, wafer head (6 each)		
4. Thumb screw (3 each)		
5. Screw, M3, TT, H/TOP,S151P X6.5 (5 each)		

3.8 Miscellaneous Plastics Kit

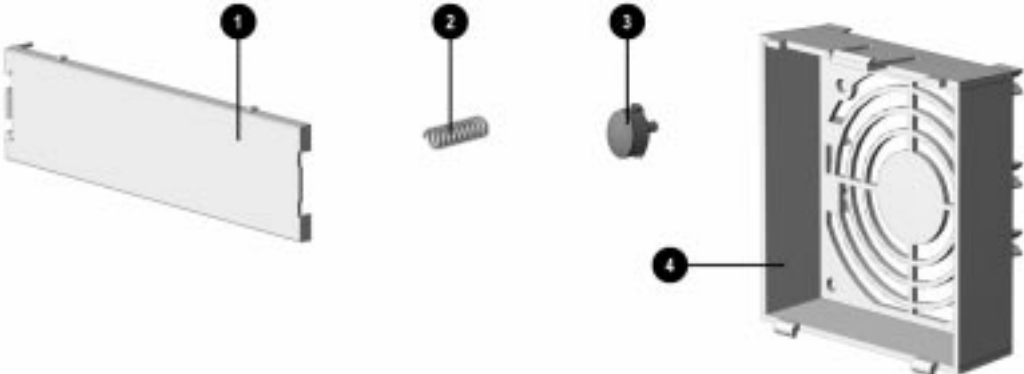


Figure 3-11. Miscellaneous Plastics Kit, Desktops

**Table 3-9
Miscellaneous Plastics Kit, Desktops**

Description	Spare Part Number	Warranty Tier
Miscellaneous plastics kit, includes: 1. Blank bezel, 1/2 height (1 each) 2. Spring (1 each) 3. Power button (1 each) 4. Card guide (1 each)	243090-001	D

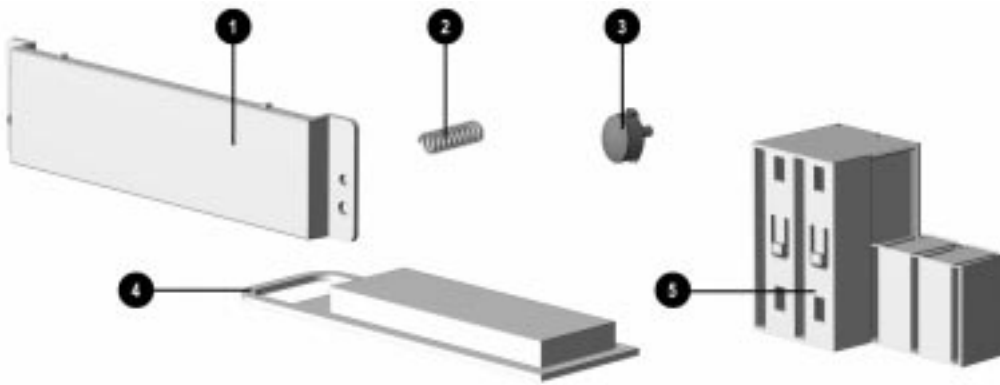


Figure 3-12. Miscellaneous Plastics Kit, Minitowers

**Table 3-10
Miscellaneous Plastics Kit, Minitowers**

Description	Spare Part Number	Warranty Tier
Miscellaneous plastics kit, includes:	243107-001	D
1. Blank bezel, 1/2 height (1 each)		
2. Spring (1 each)		
3. Power button (1 each)		
4. Retainer, ISA Option Board (1 each)		
5. Guide, Option Card (1 each)		

3.9 Miscellaneous Parts



Figure 3-13. Miscellaneous Metals Kit, Desktops

Table 3-11
Miscellaneous Metals Kit, Desktops

Description	Spare Part Number	Warranty Tier
Miscellaneous metals kit, includes:	243185-001	D
1. Floppy/hard drive cage		
2. Riser brace		

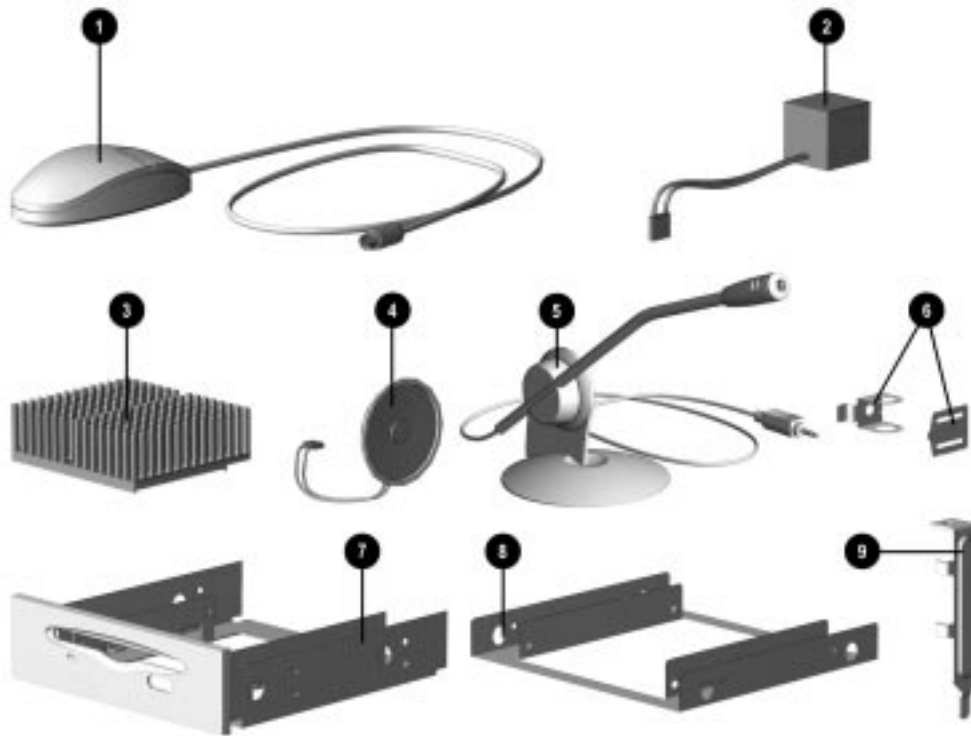


Figure 3-14. Miscellaneous Parts

**Table 3-12
Miscellaneous Parts**

Description	Spare Part Number	Warranty Tier
1. Two-button mouse	141189-401	A
2. Battery, Real-Time Clock (External)	160274-001	A
3. Heat Sink (P5-100/120/133)	214097-001	D
3. Heat Sink (P5-166/200)*	243128-001	D
3. Heat Sink (P6-180/200)*	243129-001	D
4. Speaker, 2.5", 0.5W (Audio option kit)	247508-001	D
5. Microphone assembly w/ base (Audio option kit)	194376-001	D
6. Security lock bracket	173066-001	D
7. Floppy mounting bracket, 3.5" to 5.25"	243230-001	D
8. Hard drive mounting bracket, 3.5" to 5.25"	243231-001	D
9. Bracket, board retainer	268247-001	A

* Not shown

3.10 Shipping Boxes

Table 3-13
Shipping Boxes

Description	Spare Part Number	Warranty Tier
Shipping box, desktop, 5 each	243092-001	D
Shipping box, minitower, 5 each	243108-001	D
Packing cushion, desktop	243093-001	D
Packing cushion, minitower	243109-001	D
Box and packing, V70 Monitor	255616-001	D
Shipping box, V70 Monitor (5 each)	255617-001	D
Box and packing, QV210 Monitor	210412-001	D
Shipping box, QV210 Monitor (5 each)	210413-001	D
Box and packing, QV200 Color Monitor	143393-001	D
Shipping box, QV200 Color Monitor (5 each)	143394-001	D
Box and packing, QV172 Color Monitor	149408-001	D
Shipping box, QV172 Color Monitor (5 each)	149409-001	D
Box and packing, 151FS Monitor	189573-001	D
Shipping box, 151FS Monitor (5 each)	189576-001	D
Box and packing, 1024 Monitor	189575-001	D
Shipping box, 1024 Monitor (5 each)	189578-001	D

3.11 Documentation

**Table 3-14
Documentation**

Description	Spare Part Number	Warranty Tier
Maintenance & Service Guide (desktop & minitower)	243211-001	D
Illustrated Parts Map	243210-001	D
Manual, Windows Sound System Essentials (English, French, German)	172999-001	D
Manual, Windows Sound System Essentials (English)	173006-001	D
User's Guide, QVision 210 Color Monitor	210414-001	D
User's Guide, QVision 200 AssetControl Monitor	143395-001	D
User's Guide, QVision 172 AssetControl Monitor	143533-003	D
Documentation kit (U.S.) includes:	243047-001	D
Windows 95 manual		
Reference Guide		
Program License		
Owner's Registration		
Mouse		
AC Power Cord		
Lock Bracket Assembly		
Windows NT 3.51 Workstation User's Guide (Danish)	183987-081	D
Windows NT 3.51 Workstation User's Guide (English)	183987-001	D
Windows NT 3.51 Workstation User's Guide (Finnish)	183987-351	D
Windows NT 3.51 Workstation User's Guide (French)	183987-051	D
Windows NT 3.51 Workstation User's Guide (Greek)	183987-041	D
Windows NT 3.51 Workstation User's Guide (Italian)	183987-061	D
Windows NT 3.51 Workstation User's Guide (Japanese)	183987-191	D
Windows NT 3.51 Workstation User's Guide (Latin American Spanish)	183987-161	D
Windows NT 3.51 Workstation User's Guide (Netherlands)	183987-331	D
Windows NT 3.51 Workstation User's Guide (Norwegian)	183987-091	D
Windows NT 3.51 Workstation User's Guide (Swedish)	183987-101	D
Windows NT 4.0 Workstation User's Guide (Danish)	183988-081	D
Windows NT 4.0 Workstation User's Guide (English)	183988-001	D
Windows NT 4.0 Workstation User's Guide (Finnish)	183988-351	D
Windows NT 4.0 Workstation User's Guide (French)	183988-051	D
Windows NT 4.0 Workstation User's Guide (Greek)	183988-041	D
Windows NT 4.0 Workstation User's Guide (Italian)	183988-061	D
Windows NT 4.0 Workstation User's Guide (Japanese)	183988-191	D
Windows NT 4.0 Workstation User's Guide (Latin American Spanish)	183988-161	D
Windows NT 4.0 Workstation User's Guide (Netherlands)	183988-331	D
Windows NT 4.0 Workstation User's Guide (Norwegian)	183988-091	D
Windows NT 4.0 Workstation User's Guide (Swedish)	183988-101	D

3.12 Software

**Table 3-15
Software***

Description	Spare Part Number	Warranty Tier
Diagnostics and Setup Diskettes for Commercial Desktops (Brazilian Portuguese)	275097-201	D
Diagnostics and Setup Diskettes for Commercial Desktops (Danish)	275097-081	D
Diagnostics and Setup Diskettes for Commercial Desktops (Dutch)	275097-331	D
Diagnostics and Setup Diskettes for Commercial Desktops (English)	275097-001	D
Diagnostics and Setup Diskettes for Commercial Desktops (Finnish)	275097-351	D
Diagnostics and Setup Diskettes for Commercial Desktops (French)	275097-051	D
Diagnostics and Setup Diskettes for Commercial Desktops (German)	275097-041	D
Diagnostics and Setup Diskettes for Commercial Desktops (Italian)	275097-061	D
Diagnostics and Setup Diskettes for Commercial Desktops (Japanese)	275097-291	D
Diagnostics and Setup Diskettes for Commercial Desktops (Norwegian)	275097-091	D
Diagnostics and Setup Diskettes for Commercial Desktops (Portuguese)	275097-131	D
Diagnostics and Setup Diskettes for Commercial Desktops (Spanish)	275097-071	D
Diagnostics and Setup Diskettes for Commercial Desktops (Swedish)	275097-101	D
MS DOS 6 & MS Windows User's Guide	196078-001	D
Windows NT 4.0 Workstation CD/Installation Guide for Deskpro 2000 (Danish)	183994-081	D
Windows NT 4.0 Workstation CD/Installation Guide for Deskpro 2000 (Dutch)	183994-331	D
Windows NT 4.0 Workstation CD/Installation Guide for Deskpro 2000 (English)	183994-001	D
Windows NT 4.0 Workstation CD/Installation Guide for Deskpro 2000 (Finnish)	183994-351	D
Windows NT 4.0 Workstation CD/Installation Guide for Deskpro 2000 (French)	183994-051	D
Windows NT 4.0 Workstation CD/Installation Guide for Deskpro 2000 (German)	183994-041	D
Windows NT 4.0 Workstation CD/Installation Guide for Deskpro 2000 (Italian)	183994-061	D
Windows NT 4.0 Workstation CD/Installation Guide for Deskpro 2000 (Japanese)	183994-191	D

* **NOTE:** International spares are not available from Houston. North American customers can order backup sets of all software on diskette format from the Compaq Order Center.

Continued

Table 3-15 *Continued*

Description	Spare Part Number	Warranty Tier
Windows NT 4.0 Workstation CD/Installation Guide for Deskpro 2000 (Latin American Spanish)	183994-161	D
Windows NT 4.0 Workstation CD/Installation Guide for Deskpro 2000 (Norwegian)	183994-091	D
Windows NT 4.0 Workstation CD/Installation Guide for Deskpro 2000 (Swedish)	183994-101	D
Windows NT 3.51 Workstation CD/Installation Guide for Deskpro 2000 (Danish)	183995-081	D
Windows NT 3.51 Workstation CD/Installation Guide for Deskpro 2000 (Dutch)	183995-331	D
Windows NT 3.51 Workstation CD/Installation Guide for Deskpro 2000 (English)	183995-001	D
Windows NT 3.51 Workstation CD/Installation Guide for Deskpro 2000 (Finnish)	183995-351	D
Windows NT 3.51 Workstation CD/Installation Guide for Deskpro 2000 (French)	183995-051	D
Windows NT 3.51 Workstation CD/Installation Guide for Deskpro 2000 (German)	183995-041	D
Windows NT 3.51 Workstation CD/Installation Guide for Deskpro 2000 (Italian)	183995-061	D
Windows NT 3.51 Workstation CD/Installation Guide for Deskpro 2000 (Japanese)	183995-191	D
Windows NT 3.51 Workstation CD/Installation Guide for Deskpro 2000 (Latin American Spanish)	183995-161	D
Windows NT 3.51 Workstation CD/Installation Guide for Deskpro 2000 (Norwegian)	183995-091	D
Windows NT 3.51 Workstation CD/Installation Guide for Deskpro 2000 (Swedish)	183995-101	D
IBM Auto 16/4TR Token Ring Driver Kit	194309-001	D
NetFlex 3 Drivers for Windows 3.1, Windows 95, Windows NT 3.51, OS/2 (English)	274988-001	D
NetFlex 3 Drivers for Windows 3.1, Windows 95, Windows NT 3.51, OS/2 (German)	274988-041	D
NetFlex 3 Drivers for Windows 3.1, Windows 95, Windows NT 3.51, OS/2 (French)	274988-051	D
NetFlex 3 Drivers for Windows 3.1, Windows 95, Windows NT 3.51, OS/2 (Italian)	274988-061	D
NetFlex 3 Drivers for Windows 3.1, Windows 95, Windows NT 3.51, OS/2 (Norwegian)	274988-091	D
NetFlex 3 Drivers for Windows 3.1, Windows 95, Windows NT 3.51, OS/2 (Swedish)	274988-101	D
NetFlex 3 Drivers for Windows 3.1, Windows 95, Windows NT 3.51, OS/2 (Latin American Spanish)	274988-161	D
NetFlex 3 Drivers for Windows 3.1, Windows 95, Windows NT 3.51, OS/2 (Brazilian Portuguese)	274988-201	D

* **NOTE:** International spares are not available from Houston. North American customers can order backup sets of all software on diskette format from the Compaq Order Center.

Continued

Table 3-15 *Continued*

Description	Spare Part Number	Warranty Tier
NetFlex 3 Drivers for Windows 3.1, Windows 95, Windows NT 3.51, OS/2 (Japanese)	274988-291	D
NetFlex 3 Drivers for Windows 3.1, Windows 95, Windows NT 3.51, OS/2 (Dutch)	274988-331	D
IDE CD-ROM Driver Diskette Kit (English)	181456-001	D
IDE CD-ROM Driver Diskette Kit (French)	181456-051	D
IDE CD-ROM Driver Diskette Kit (German)	181456-041	D
IDE CD-ROM Driver Diskette Kit (Italian)	181456-061	D
IDE CD-ROM Driver Diskette Kit (Spanish)	181456-071	D
IDE CD-ROM Driver Diskette Kit (Danish)	181456-081	D
IDE CD-ROM Driver Diskette Kit (Norwegian)	181456-091	D
IDE CD-ROM Driver Diskette Kit (Swedish)	181456-101	D
IDE CD-ROM Driver Diskette Kit (Portuguese)	181456-131	D
IDE CD-ROM Driver Diskette Kit (Dutch)	181456-331	D
IDE CD-ROM Driver Diskette Kit (Finnish)	181456-351	D
Mouse Driver Kit (US/UK)	133421-001	D
Mouse Driver Kit (German)	133421-041	D
Mouse Driver Kit (French)	133421-051	D
Mouse Driver Kit (Italian)	133421-061	D
Mouse Driver Kit (Spanish)	133421-071	D
LS-120 Floptical drivers	183989-001	D
Desktop management 3.0 Agents	183990-001	D
SCO Unix Support Drivers	125873-001	D
OS/2 Support Drivers	196004-001	D
Windows NT Support Drivers	196012-001	D
Flash for System ROM	183986-001	D
QVision 2000+ Windows Display Software	148213-001	D
QVision Windows/ADI Video Drivers	196153-001	D
PCI Local Bus Display Software (CL 5446)	181207-001	D
ESS 1868 Audio Drivers	274987-001	D
Microsoft Windows Sound System (English)	195831-001	D
Microsoft Windows Sound System (German)	195831-041	D
Microsoft Windows Sound System (French)	195831-051	D
QuickFind for Windows CD-ROM Kit (US)	137906-0XX**	D
QuickFind for Windows CD-ROM Kit (Outside US)	137907-0XX**	D

* **NOTE:** International spares are not available from Houston. North American customers can order backup sets of all software on diskette format from the Compaq Order Center.

** **NOTE:** QuickFind is updated monthly. To complete the QuickFind part number add the suffix from Table 3-17 for the desired month. If you do not specify the 3-digit suffix the default is the current month in which the order is placed.

chapter 4

REMOVAL AND REPLACEMENT PRELIMINARIES

This chapter provides general service information for the computer. Adherence to the procedures and precautions described in this chapter is essential for proper service.

4.1 Electrostatic Discharge Information

A sudden discharge of static electricity from your finger or other conductor can destroy static-sensitive devices or microcircuitry. Often the spark is neither felt nor heard, but damage occurs. An electronic device exposed to electrostatic discharge (ESD) may not be affected at all and can work perfectly throughout a normal cycle. Or it may function normally for a while, then degrade in the internal layers, reducing its life expectancy.

Networks built into many integrated circuits provide some protection, but in many cases, the discharge contains enough power to alter device parameters or melt silicon junctions.

4.1.1 Generating Static

Table 4-1 shows how different activities generate static electricity at different electrostatic voltage levels.

Table 4-1
Typical Electrostatic Voltages

Event	Relative Humidity		
	10%	40%	55%
Walking across carpet	35,000 V	15,000 V	7,500 V
Walking across vinyl floor	12,000 V	5,000 V	3,000 V
Motions of bench worker	6,000 V	800 V	400 V
Removing DIPs* from plastic tube	2,000 V	700 V	400 V
Removing DIPs* from vinyl tray	11,500 V	4,000 V	2,000 V
Removing DIPs* from Styrofoam	14,500 V	5,000 V	3,500 V
Removing bubble pack from PCB	26,500 V	20,000 V	7,000 V
Packing PCBs in foam-lined box	21,000 V	11,000 V	5,000 V

*Dual Inline Packaging (DIP) is the packaging around individual microcircuitry. These are then multi-packaged inside plastic tubes, trays, or Styrofoam.

 700 volts can degrade a product.

4.1.2 Preventing Electrostatic Damage to Equipment

Many electronic components are sensitive to ESD. Circuitry design and structure determine the degree of sensitivity. The following proper packaging and ground precautions are necessary to prevent damage to electric components and accessories.

- To avoid hand contact, transport products in static-safe containers such as tubes, bags, or boxes.
- Protect all electrostatic parts and assemblies with conductive or approved containers or packaging.
- Keep electrostatic sensitive parts in their containers until they arrive at static-free stations.
- Place items on a grounded surface before removing them from their container.
- Always be properly grounded when touching a sensitive component or assembly.
- Avoid contact with pins, leads, or circuitry.
- Place reusable electrostatic-sensitive parts from assemblies in protective packaging or conductive foam.

4.1.3 Personal Grounding Methods

The method for grounding must include either a wrist strap or a foot strap at a grounded workstation. When seated, wear a wrist strap connected to a grounded system. When standing, use footstraps and a grounded floor mat.

Table 4-2
Static Shielding Protection Levels

Method	Voltage
Antistatic plastic	1,500
Carbon-loaded plastic	7,500
Metallized laminate	15,000

4.1.4 Grounding Workstations

To prevent static damage at the workstation, use the following precautions:

- Cover the workstation with approved static-dissipative material. Provide a wrist strap connected to the work surface and properly grounded tools and equipment.
- Use static-dissipative mats, foot straps, or air ionizers to give added protection.
- Handle electrostatic sensitive components, parts, and assemblies by the case or PCB laminate. Handle them only at static-free workstations.
- Turn off power and input signals before inserting and removing connectors or test equipment.
- Use fixtures made of static-safe materials when fixtures must directly contact dissipative surfaces.
- Keep work area free of nonconductive materials such as ordinary plastic assembly aids and Styrofoam.
- Use field service tools, such as cutters, screwdrivers, and vacuums, that are conductive.
- Use a portable field service kit with a static-dissipative vinyl pouch that folds out on a work mat. Also, use a wrist strap and a ground cord for the work surface. Ground the cord to the chassis of the equipment undergoing test or repair.

4.1.5 Personal Grounding Equipment

Use the following equipment to prevent static electricity damage to equipment:

Wrist Straps are flexible straps with a minimum of one-megohm +/- 10% resistance in the ground cords. To provide proper ground, a strap must be worn snug against bare skin. The ground cord must be connected and fit snugly into the banana plug connector on the grounding mat or workstation.

Heelstraps/Toestraps/Bootstraps can be used at standing workstations and are compatible with most types of shoes or boots. On conductive floors or dissipative floor mats, use them on both feet with a minimum of one-megohm resistance between the operator and ground. To be effective, the conductive strips must be worn in contact with the skin.

4.1.6 Recommended Materials and Equipment

Other materials and equipment that are recommended for use in preventing static electricity include:

- Antistatic tape
- Antistatic smocks, aprons, or sleeve protectors
- Conductive bins and other assembly or soldering aids
- Conductive foam
- Conductive tabletop workstations with ground cord of one-megohm resistance
- Static-dissipative table or floor mats with hard tie to ground
- Field service kits
- Static awareness labels
- Wrist straps and footwear straps providing one-megohm +/- 10% resistance
- Material handling packages
- Conductive plastic bags
- Conductive plastic tubes
- Conductive tote boxes
- Opaque shielding bags
- Transparent metallized shielding bags
- Transparent shielding tubes

4.2 Service Considerations

Listed below are some of the considerations that you should keep in mind during the disassembly and assembly of the computer.

4.2.1 Tools and Software Requirements

To service the computer, you need the following:

- Torx T-10 and T-15 screwdrivers
- Flat-bladed screwdriver
- Diagnostics software

4.2.2 Screws

The screws used in the computer are not interchangeable. They may have standard or metric threads and may be of different lengths. If an incorrect screw is used during the reassemble process, it can damage the unit. Compaq strongly recommends that all screws removed during disassembly be kept with the part that was removed, then returned to their proper locations.

IMPORTANT: As each subassembly is removed from the computer, it should be placed away from the work area to prevent damage.

4.2.3 Cables and Connectors

Most cables used throughout the unit are flat, flexible cables. These cables must be handled with extreme care to avoid damage. Apply only the tension required to seat or unseat the cables during insertion or removal from the connector. Handle cables by the connector whenever possible. In all cases, avoid bending, twisting, or tearing the cables, and ensure that the cables are routed in such a way that they cannot be caught or snagged by parts being removed or replaced.



CAUTION: When servicing this computer, ensure that cables are placed in their proper location during the reassembly process. Improper cable placement can damage the computer.

4.2.4 Hard Drives

Handle hard drives as delicate precision components, avoiding all physical shock and vibration. This applies to failed drives as well as spares.

- Use only the packaging provided by Compaq for shipping.
- Do not remove hard drives from the shipping package for storage.
Keep hard drives in their protective packaging until they are actually mounted in the CPU or external storage unit.
- Avoid dropping drives from any height onto any surface.

4.2.5 Plastic Parts

Plastic parts can be damaged by the use of excessive force during disassembly and reassembly. When handling the plastic parts, use care. Do not use a screwdriver or similar tool to pry apart the plastic components.

4.2.6 Lithium Battery

The battery that came with the computer is nonreplaceable and is permanently soldered onto the system board. Do not attempt to remove the lithium battery when installing a replacement battery. The lithium battery may explode if mishandled.



CAUTION: Never attempt to remove a lithium battery. You can damage the system board in such an attempt, thereby making it unusable. Do not abuse or disassemble the lithium battery, as it may explode if mistreated.

chapter 5

REMOVAL AND REPLACEMENT PROCEDURES

This chapter provides subassembly/module level removal and replacement procedures for the Compaq Deskpro 2000 Series of Personal Computers. The Chapter is divided into two major subsections:

- Section 5.1 presents the information needed for a Compaq Deskpro 2000 Series Desktop Personal Computer
- Section 5.2 presents the information for a Compaq Deskpro 2000 Series Minitower Personal Computer.

After completing all necessary removal and replacement procedures, run the Diagnostics program to verify that all components operate properly.

5.1 Desktop Instructions

This section describes the removal and replacement procedures for the desktop models of the Compaq Deskpro 2000 Series of Personal Computer.

5.1.1 Serial Number

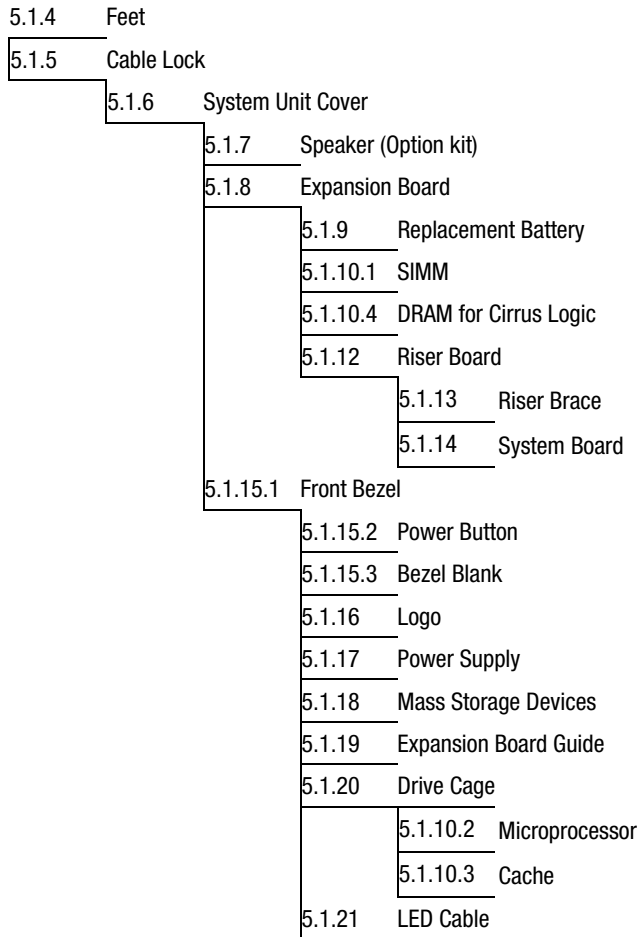
The computer serial number should be provided to Compaq whenever requesting information or ordering spare parts. The serial number is located on the right side of the system unit cover, toward the front **1** and also on the rear of the chassis in the expansion slot area **2**.



Figure 5-1. Serial Number Location: Desktops

5.1.2 Disassembly/Assembly Sequence Chart

5.1.2.1 Desktop Computer - Pentium-Based System Board



5.1.2.2 Desktop Computer - Pentium Pro Based System Board

5.1.4	Feet
5.1.5	Cable Lock
5.1.6	System Unit Cover
5.1.7	Speaker (Option kit)
5.1.8	Expansion Board
5.1.9	Replacement Battery
5.1.10.2	Microprocessor
5.1.11.1	WRAM for Matrox MGA (P6/200)
5.1.11.2	DRAM for Cirrus Logic (P6/180)
5.1.12	Riser Board
5.1.13	Riser Brace
5.1.14	System Board
5.1.15.1	Front Bezel
5.1.15.2	Power Button
5.1.15.3	Bezel Blank
5.1.16	Logo
5.1.17	Power Supply
5.1.18	Mass Storage Devices
5.1.19	Expansion Board Guide
5.1.20	Drive Cage
5.1.10.1	SIMM

5.1.3 Preparation for Disassembly

To prepare the computer for the removal and replacement procedures, complete the following steps:

1. Remove any diskette, compact disc, or tape from the computer.
2. Turn off the computer and any peripheral devices that are connected to the computer.



CAUTION: The computer power switch should be turned off before you disconnect any cables.

3. Disconnect the power cord from the electrical outlet and then from the computer.
 4. Disconnect all peripheral device cables from the computer.
- ✍ During disassembly, label each cable as you remove it, noting its position and routing.

5.1.4 Feet

Four rubber feet are mounted to the underside of the base pan. No parts have to be removed to access the feet. The replacement feet have an adhesive surface and are shipped with a protective strip in place. Remove the protective strip from the replacement feet before installation.

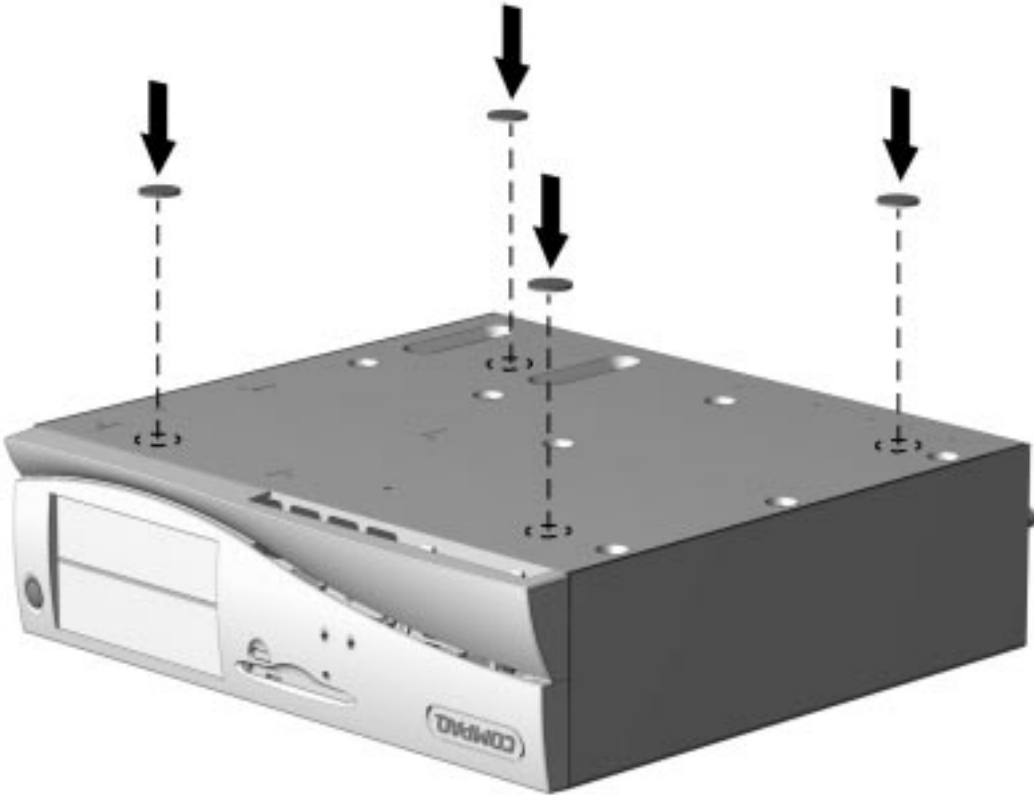


Figure 5-2. *Installing the Feet*

5.1.5 Cable Lock

To install the cable lock provision, complete the following steps:

1. Remove one thumbscrew from the rear of the computer. Use a coin or flat-bladed screwdriver, if needed.
2. Position the bottom part of the cable lock provision over the screw hole and install the screw provided in the cable lock kit.
3. Cover the screw with the top part of the cable lock provision.
4. Install a lock (not provided) to secure the top part of the cable lock provision.

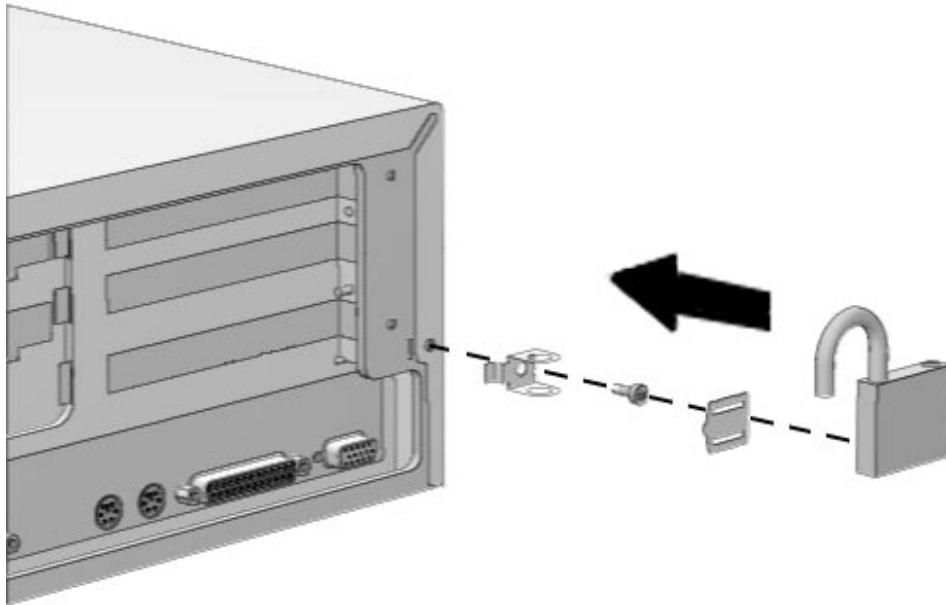


Figure 5-3. Cable Lock Provision on the Desktop Computer

To remove the cable lock provision, reverse the above procedure.

5.1.6 System Unit Cover

To remove the system unit cover, complete the following steps:

1. Perform preparation procedures described in Section 5.1.3.
 2. Remove the two thumbscrews on the rear of the computer to release the cover. You may need a flat-bladed screwdriver or a coin to loosen the screws.
- ✎ If the computer has a cable lock mechanism installed in place of one of the thumbscrews, refer to Section 5.1.5.

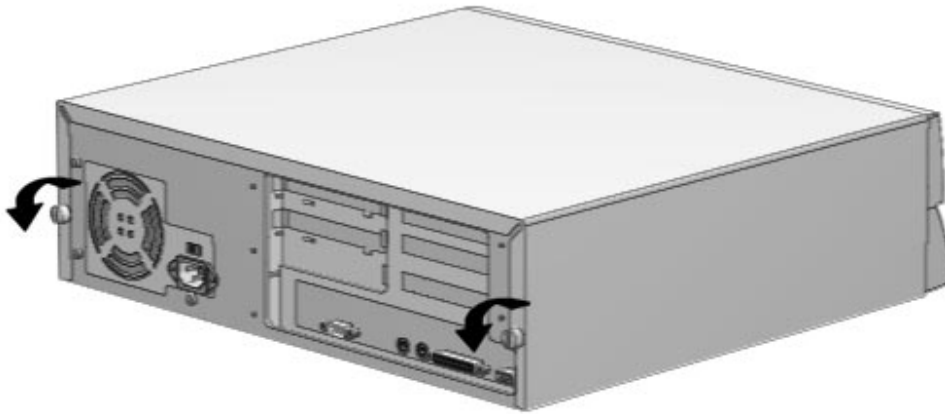


Figure 5-4. Loosening the Desktop Thumbscrews

3. Slide the desktop computer cover backward about 1 inch (2.5 cm); then, lift it up and off the unit.

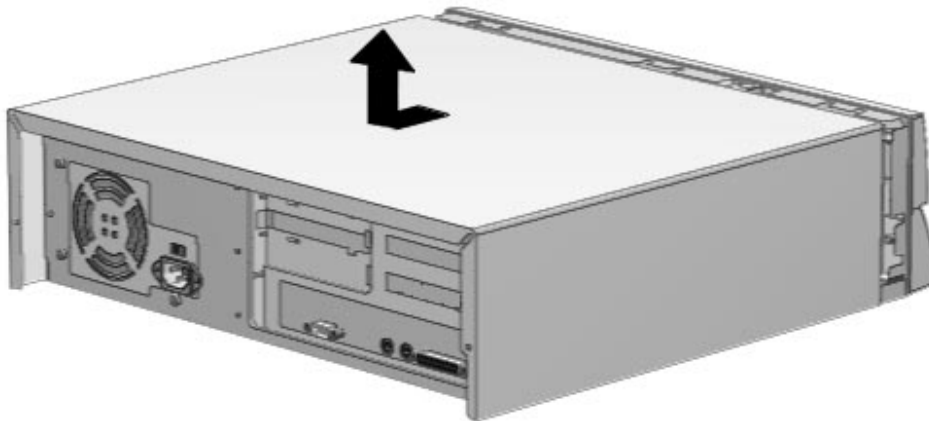


Figure 5-5. Removing the Desktop Unit Cover

The internal components of the computer are now accessible for service. To replace the unit cover, reverse the above procedure.

5.1.7 Speaker

To remove the speaker, complete the following steps:

1. Perform the preparation procedures described in Section 5.1.3.
2. Remove the system unit cover (Section 5.1.6).
3. Disconnect the speaker cable from the Business Pro Audio board.



Figure 5-6. Disconnecting the Audio Cable from the Business Pro Audio Board

4. Unsnap the speaker-retaining clip on the right side of the drive bay and remove the speaker.

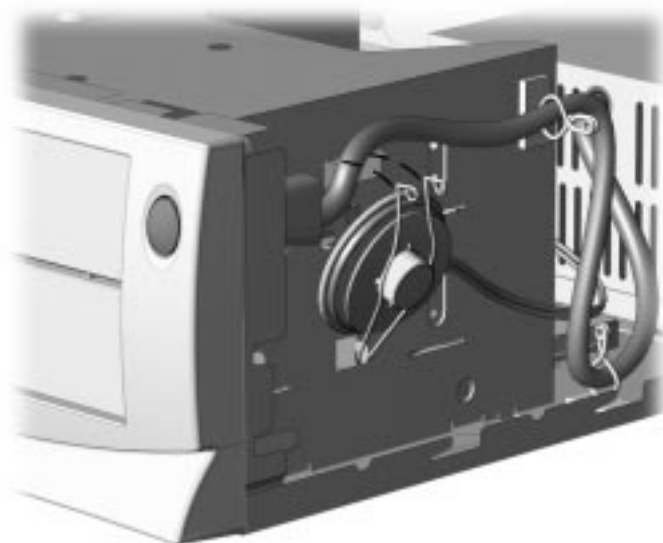


Figure 5-7. Removing the Speaker

To replace the speaker, ensure that the cardboard insulator is on the speaker then, reverse the above procedure.



Figure 5-8. *Installing the Cardboard Insulator and the Retaining Clip onto the Speaker*

5.1.8 Expansion Board

The Compaq Deskpro 2000 Series of Personal Computers contains five expansion slots: three slots are located on the outboard side of the riser board and two slots are located on the inboard side of the riser board.

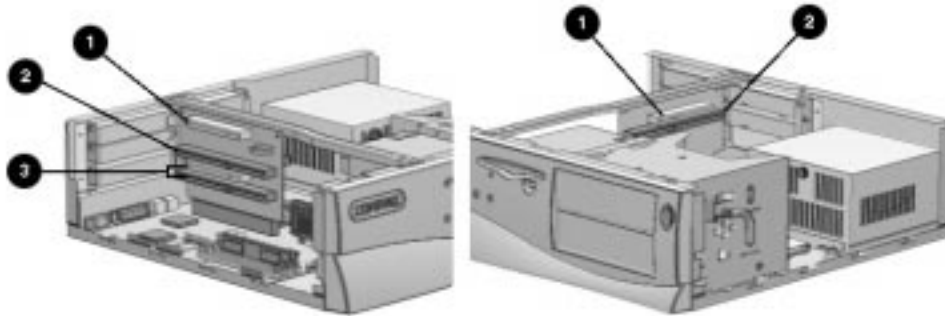


Figure 5-9. Five Expansion Slots on the Desktop Computer

- ❶ Two dedicated PCI (Peripheral Component Interconnect) expansion slots, one on each side of the expansion riser board.
- ❷ Two dedicated ISA (Industry Standard Architecture) expansion slots, one on each side of the expansion riser board.
- ❸ One PCI/ISA shared expansion slot.

5.1.8.1 Inboard Expansion Board

To remove an inboard expansion board follow these steps:

1. Perform preparation procedures described in Section 5.1.3.
2. Remove the system unit cover. (Section 5.1.6).
3. Remove the retaining screw and board retainer bracket that secure the board to the rear of the computer.

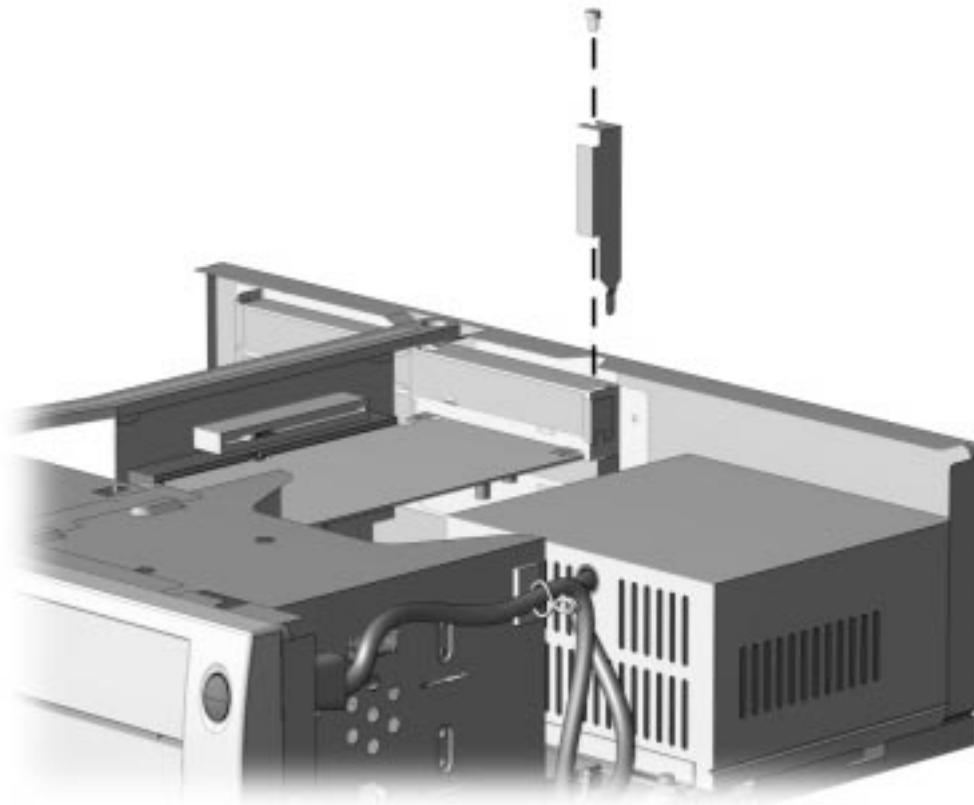


Figure 5-10. Removing the Clip Retaining Screw and the Retainer Bracket

4. Remove the expansion board.

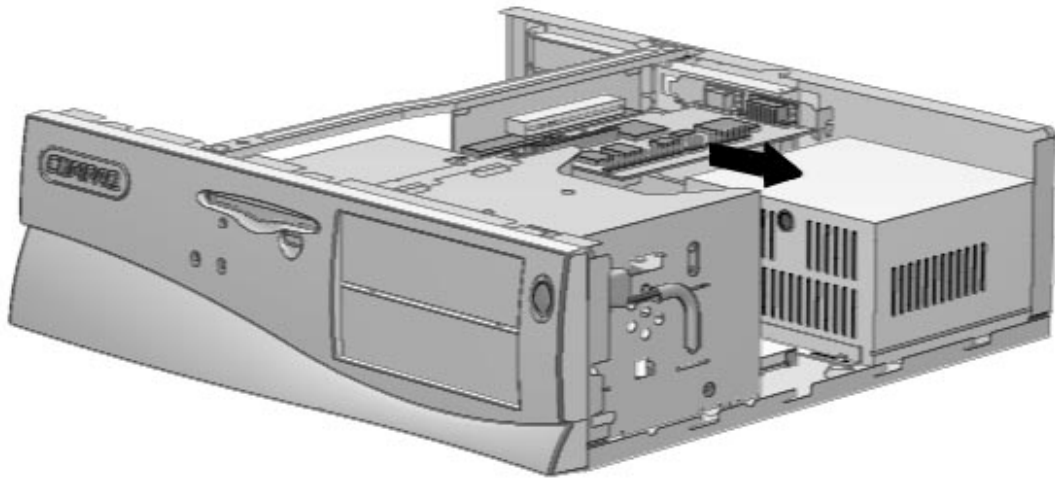


Figure 5-11. Removing an Expansion Board from an Expansion Slot (Shown: Matrox Millennium Graphics Board in PCI Slot)

To install an inboard expansion board, complete the following steps:

1. Slide the expansion board into the expansion slot and press it firmly into place.
2. Replace the retainer bracket and the retaining screw.

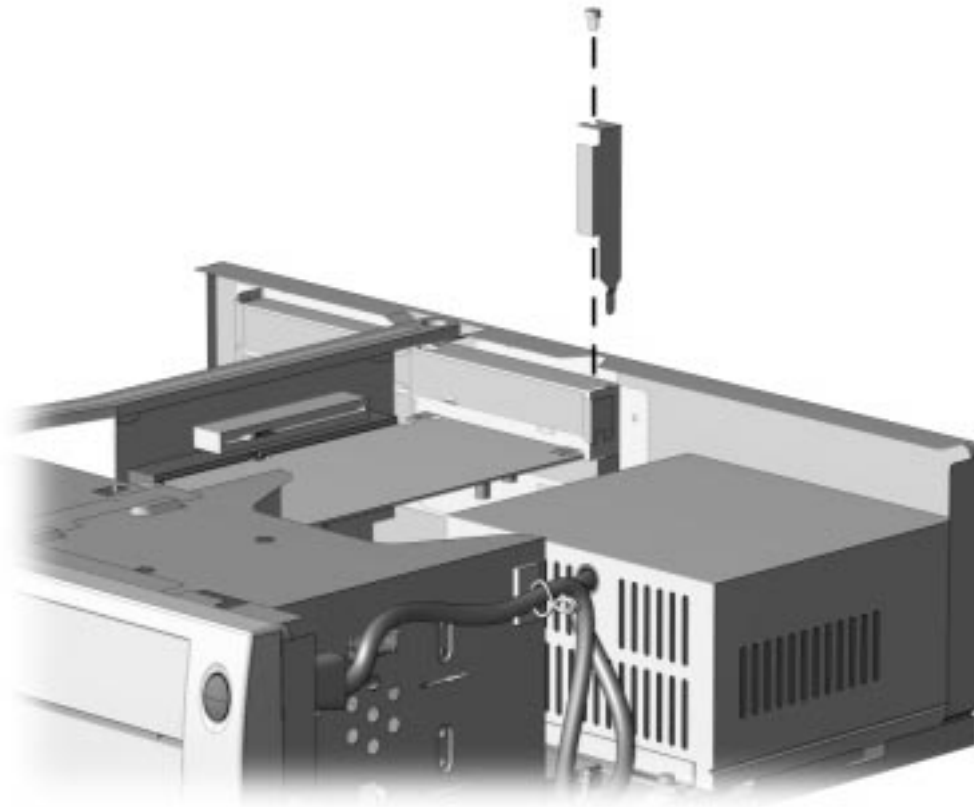


Figure 5-12. *Replacing the Retainer Bracket and the Retaining Screw*

3. Replace the system unit cover.
4. To reconfigure the computer to recognize the added expansion board, run the Computer Setup utility to reconfigure the system. Refer to Chapter 7, “Compaq Utilities.”
5. Test the computer (optional) using the Computer Checkup (TEST) utility. Refer to Chapter 2, “Troubleshooting.”

5.1.8.2 Outboard Expansion Board

To remove an outboard expansion board, complete the following steps:

1. Perform preparation procedures described in Section 5.1.3.
2. Remove the system unit cover. (Section 5.1.6).
3. Remove the retaining screw that secures the board to the rear of the computer.
4. Remove the expansion board.

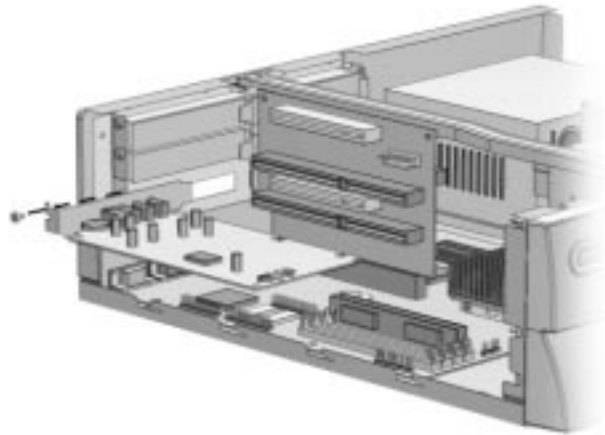


Figure 5-13. Removing an Expansion Board

To install an outboard expansion board, complete the following steps:

1. Slide the expansion board into the expansion slot and press it firmly into place.
2. Replace the retaining screw.
- ✎ If you are installing an expansion board for the first time in an outboard position, remove the retaining screw and the expansion board cover before installing the board.
3. Replace the system unit cover.
4. To reconfigure the computer to recognize the added expansion board, run the Computer Setup utility. Refer to Chapter 7, “Compaq Utilities.”
5. Test the computer (optional) using the Computer Checkup (TEST) utility. Refer to Chapter 2, “Troubleshooting.”

5.1.9 Replacement Battery

The real-time clock battery that came with the computer is nonreplaceable and is permanently installed on the system board. Use Compaq replacement battery 160274-001 or a comparable 600-milliamp alkaline, 4.5-volt battery.

- ✎ It is important to make a set of backup diagnostics diskettes before you install a new battery.
- ✎ If a non-Compaq hard drive is installed in the computer, it is important to take the following steps *before* installing the battery.
 1. Run the Computer Setup utility and observe the drive type that is displayed in the System Configuration summary.
 2. If the drive type number is 65 or 66, make a note of the drive parameters. You can view these parameters by turning off the computer and then, restarting it, pressing **F10** when the square cursor appears in the upper-right corner of the screen. From the Compaq Utilities menu, select Computer Setup. Select Storage, then select Configure Fixed Disk Drive to view the parameters. It is important to record these parameters before continuing.
 3. When you have completed the battery installation, run the Computer Setup utility to reconfigure the system. Refer to Chapter 7, “Compaq Utilities.”

To install the external real-time clock battery, complete the following steps:

1. Perform preparation procedures described in Section 5.1.3.
2. Remove the system unit cover (Section 5.1.6).



WARNING: The system board contains a clock/CMOS lithium battery. The lithium battery may explode if mistreated. The battery is soldered in and may not be removed. Do not abuse or disassemble. Use only replacement batteries supplied by Compaq Computer Corporation (spare part number 160274-001).

3. Connect the new battery to the pins on the E9 battery header connector.

The battery connector is keyed for proper installation.

✎ Connecting the replacement battery to the pins automatically disconnects the internal battery.

E8	E6 Passwd.	E9
• • • • •	• • • • •	• • • • •
Clear CMOS	5-6=ENA 6-7=DIS	Ext. Batt.

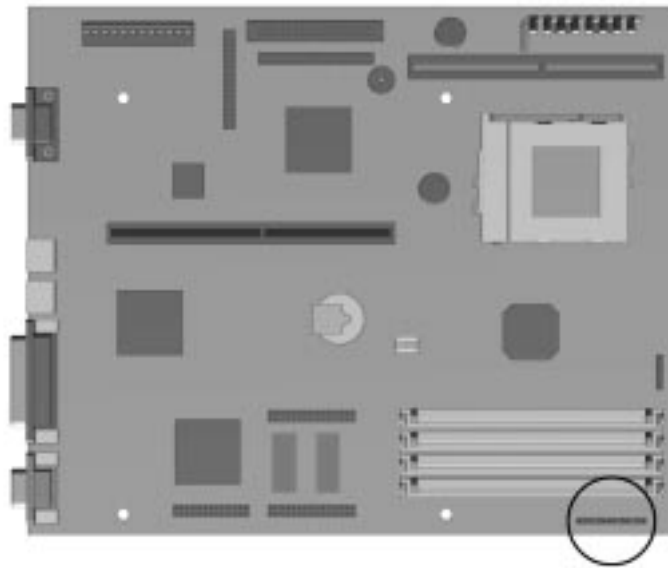


Figure 5-14. Battery Connection Location

4. Remove the backing from the adhesive on the hook-and-loop fastener strip, and attach the battery with the hook-and-loop fastener strip as shown.

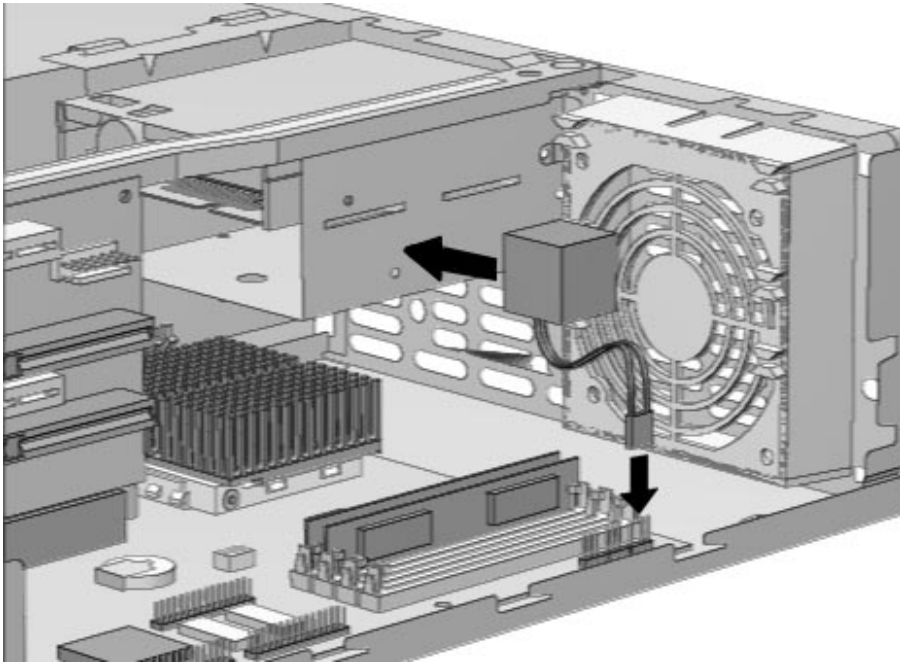


Figure 5-14. *Installing the Battery on the Desktop*

5. Replace the system unit cover.
6. Place the sticker included with your battery kit on the back of your computer above the power connector.
7. Plug in the computer and reconnect any external devices.



WARNING: This equipment is designed for connection to a grounded (earthed) outlet. The grounding type plug is an important safety feature. To avoid the risk of electrical shock or damage to the equipment, do not disable this feature.

8. Turn on the computer.
9. Run the Computer Setup utility to reconfigure the system. Refer to Chapter 7, "Compaq Utilities."

5.1.10 System Board Components

5.1.10.1 Memory Modules

You can expand computer memory by installing industry standard single inline memory modules (SIMMs) on the system board.

There are four memory sockets that can be populated when installing memory on the Pentium system board and six memory sockets on the Pentium Pro system board.

SIMMs are installed in equally matched pairs; for example, two 8-megabyte modules, two 16-megabyte modules, or two 32-megabyte modules. If you are mixing EDO and FPM DRAM, identical modules must be installed two at a time, for example, two EDO modules of the same type, speed, and size; or two FPM DRAM modules of the same type, speed, and size.

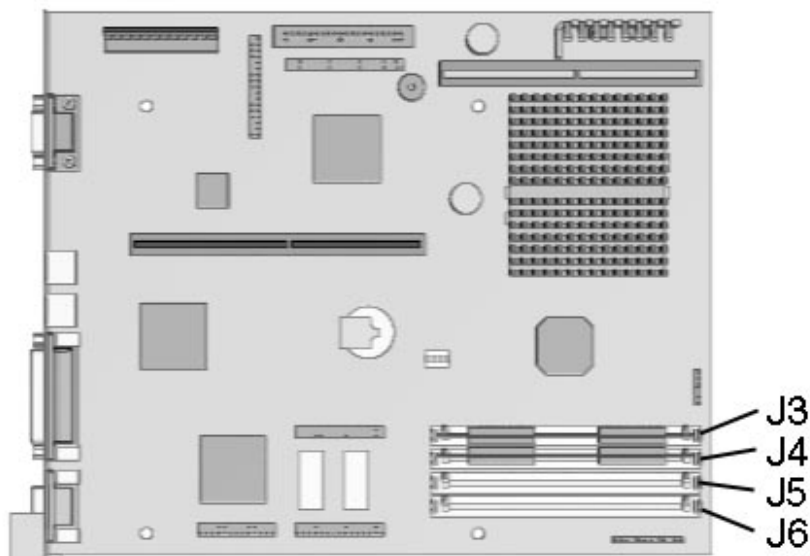


Figure 5-16. Four Memory Sockets on the Pentium-Based System Board



CAUTION: Static electricity can damage the electronic components of the computer or optional equipment. Before beginning these procedures, ensure that you are discharged of static electricity by briefly touching a grounded metal object.

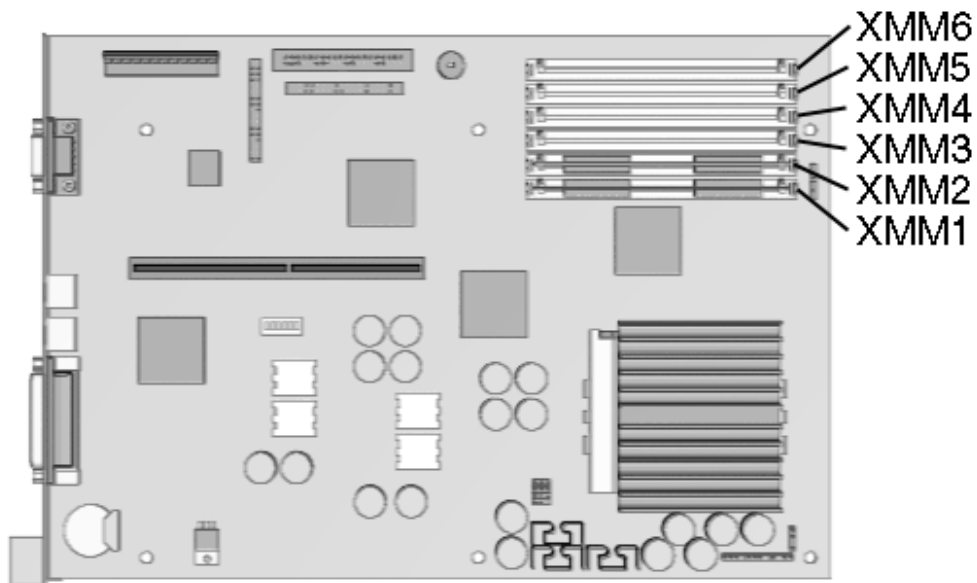


Figure 5-17. Six Memory Module Sockets on the Pentium Pro-Based System Board

Memory Upgrades		
Model	Standard	Expandable to:
Pentium-based system	8-, 16-, or 32-MB DRAM	128-MB DRAM
Pentium Pro-based system	16- or 32-MB DRAM	192-MB DRAM

CAUTION: When handling a memory module, be careful not to touch any of the contacts. Doing so may damage the module.

To install a memory module, complete the following steps:

1. Perform preparation procedures described in Section 5.1.3.
2. Remove the system unit cover (Section 5.1.6).
3. If this is a Pentium-based computer, remove any outboard expansion boards that block the SIMM sockets (Section 5.1.8.2) and continue with Step 4.

If this is a Pentium Pro-based computer, remove the front bezel (Section 5.1.15) and the drive cage (Section 5.1.20). Then continue with Step 4.

4. Insert a memory module at a 45-degree angle into a memory socket on the system board.

A memory module can only be installed one way. Match the notch on the module with the tab on the memory socket. Push the module down into the socket, ensuring that the module is fully inserted and properly seated.

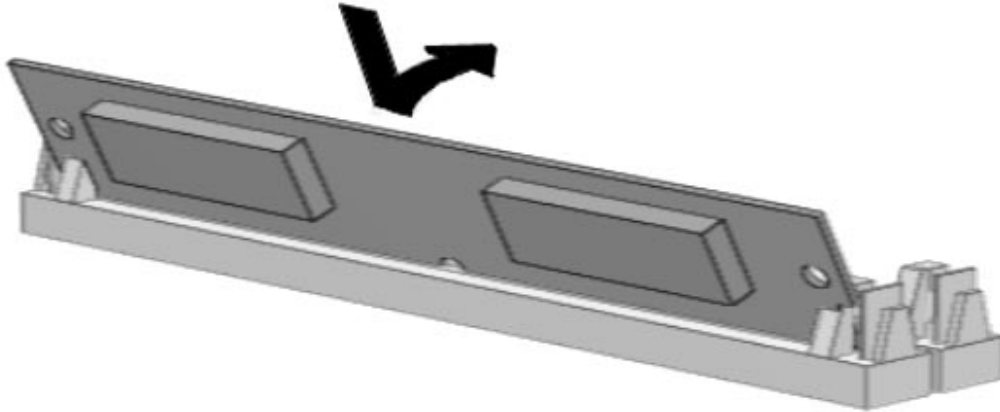


Figure 5-18. *Installing a Memory Module*

5. Rotate the module to an upright position, allowing the latches to snap into place.
6. Repeat steps 4 and 5 for each module that you want to install.
7. Replace the system unit cover.
8. The computer recognizes system memory upgrades and automatically reconfigures the computer. If, for some reason, the memory upgrades do not configure correctly, run Computer Setup to reconfigure the computer. Refer to Chapter 7, "Compaq Utilities," for information on running Computer Setup.
9. Test the system (optional) using the Computer Checkup (TEST) utility. Refer to Chapter 2, "Troubleshooting."

To replace a memory module, follow these steps.

1. Perform preparation procedures described in Section 5.1.3.
2. Remove the system unit cover (Section 5.1.6).
3. Release the latches and rotate the module to a 45-degree position.
4. Lift the memory module out of the socket.
5. Replace the memory module as described in the in the preceding procedures.

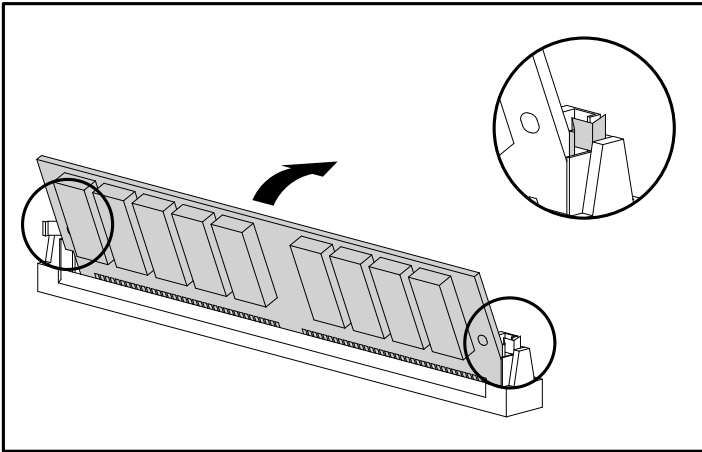


Figure 5-19. *Rotating the Memory Module Upright.*

6. Replace the system unit cover.

5.1.10.2 Microprocessor

To remove the microprocessor from the system board, complete the following steps:

1. Perform preparation procedures described in Section 5.1.3.
2. Remove the system unit cover (Section 5.1.6).



WARNING: To reduce the risk of personal injury from hot surfaces, allow the internal system components to cool before touching.



CAUTION: When replacing a Pentium processor, you must release the heatsink retaining clip before you pull the ZIF socket handle. This clip engages the processor socket to hold the heatsink in place.

3. If this is a Pentium-based system board, remove the front bezel (Section 5.1.15.1) and the drive cage (Section 5.1.20).

If this is a Pentium Pro-based system board, remove any outboard expansion boards that interfere with the processor (Section 5.1.8).

4. Remove the heatsink retaining clip ❶ by pressing down on the clip's extended tab until it releases from the safety catch.
5. Lift the heatsink ❷ off the processor.
6. Release the original processor from the socket by pulling the handle on the ZIF socket out ❸ and upward ❹.
7. Lift the processor ❺ out of the socket.

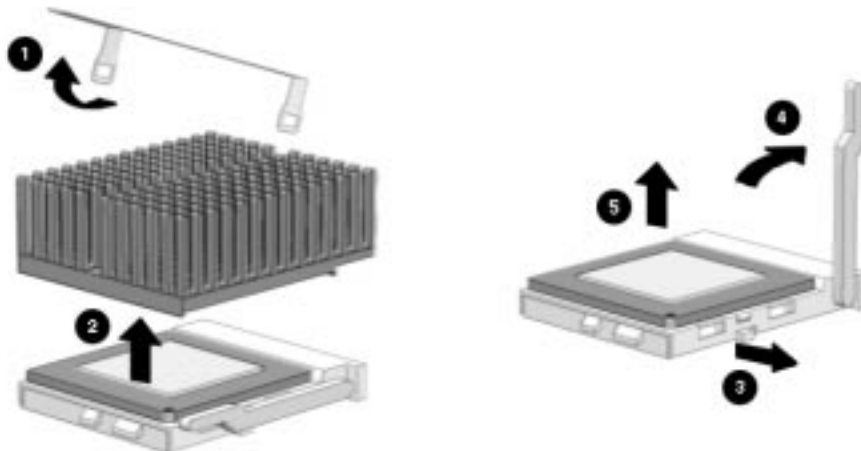


Figure 5-20. Removing the Microprocessor from the System Board



CAUTION: When replacing the processor, be sure that the clipped corner of the processor (location of Pin 1) is aligned with the triangular area of the ZIF socket (hinged corner). Failure to do so could result in burning out both the processor and the system board.


Depending on the model, you can upgrade the processor by replacing the processor currently installed with a processor upgrade.

Processor Supported Upgrades

Base processor	Can be upgraded to
P5/100	P5/120, P5/133, P5/166, and P5/200
P5/120	P5/133, P5/166, and P5/200
P5/133	P5/166 and P5/200
P5/166	P5/200
P6/180	P6/200



CAUTION: Installing the processor upgrade incorrectly may cause damage to the processor board. Compaq recommends that you have a Compaq authorized reseller or service provider install the processor upgrade. If you plan to install it yourself, read all the instructions carefully before you begin.

 The handle on the ZIF socket in your computer may not look identical to the handle shown in the drawing. All handle types perform the same function.

To install a processor, complete the following steps:

1. Install the processor by lowering it into the ZIF socket. Ensure that pin 1 on the processor lines up with pin 1 on the ZIF socket.
2. Push the handle on the ZIF socket back into place to secure the processor.

3. If the processor has a raised center, install thermal pad number 243226-001 on top of the processor before installing the heatsink.

If the process or has a flat surface, install thermal pad number 184616-002 before installing the heatsink.



CAUTION: Using the wrong thermal pad may cause the processor to overheat or short, resulting in failure.

4. Install the heatsink and the heatsink retaining clip.

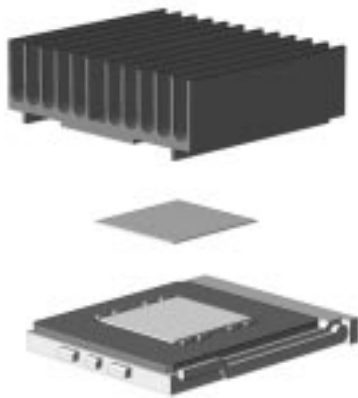


Figure 5-21. *Installing the Thermal Pad*

5. Replace the system unit cover.
6. Run the Computer Setup utility. Refer to Chapter 7, "Compaq Utilities."
7. Test the system (optional) using the Computer Checkup (TEST) utility. Refer to Chapter 2, "Troubleshooting."

5.1.10.3 Cache Memory

To install an optional cache module onto a Pentium-based system board, complete the following steps:

1. Perform preparation procedures described in Section 5.1.3.
2. Remove the system unit cover (Section 5.1.6).
3. Remove the front bezel (Section 5.1.15.1).
4. Remove the drive cage (Section 5.1.20).
5. Locate the cache connector on the system board.

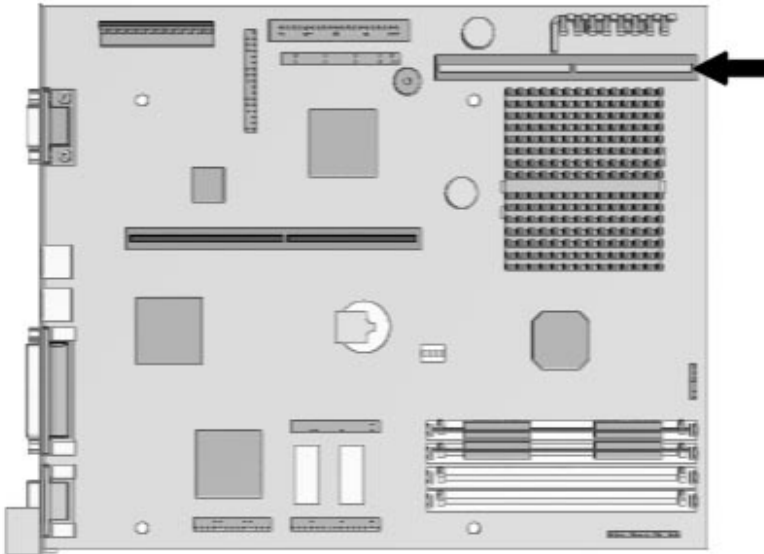


Figure 5-22. Locating the Cache Connector on the System Board

6. Install the cache module into the cache connector on the system board.
7. Replace the system unit cover.
8. Reconnect all the cables and turn on the computer. The computer reconfigures the additional memory. Refer to Chapter 7, "Compaq Utilities."

5.1.10.4 PCI Performance Graphics Controller Memory Module Upgrade

To install a graphics memory module upgrade for the Cirrus Logic Performance graphics controller that is preinstalled in the system board, complete the following steps:

1. Perform preparation procedures described in Section 5.1.3.
2. Remove the system unit cover (Section 5.1.6).
3. Remove any outboard expansion boards that might block access to the controller slot (Section 5.1.8).
4. Install the graphics upgrade module onto the system board.

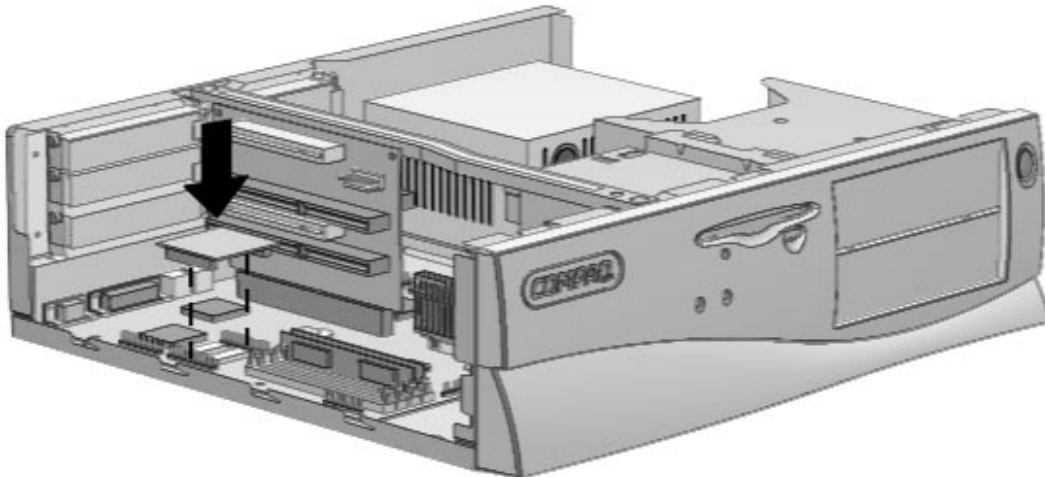


Figure 5-23. Installing a 1-MB EDO DRAM Module onto the System Board

5. Replace the system unit cover.
6. Turn the computer on and start the Windows program.
7. Select the Display icon in the Compaq Utilities group box in Windows NT 3.51 or Windows 3.1, or the Display icon in Windows 95, to take advantage of the additional display modes now available with the upgraded memory. Follow the instructions on the screen.
8. Test the system (optional) using the Computer Checkup (TEST) utility. Refer to Chapter 2, "Troubleshooting."

5.1.11 Expansion Board Components

5.1.11.1 Matrox MGA Millennium Graphics Controller

To install additional WRAM onto the Matrox MGA Millennium Graphics board, complete the following steps:

1. Perform preparation procedures described in Section 5.1.3.
 2. Remove the system unit cover (Section 5.1.6).
 3. Remove the expansion board (Section 5.1.8).
 4. Place the graphics board on a flat surface and install the upgrade module.
- ✎ Ensure that all pins on the connector are properly aligned to avoid damaging the memory module and/or the graphics controller.

If you are removing a memory module, rock the module gently while pulling it up.

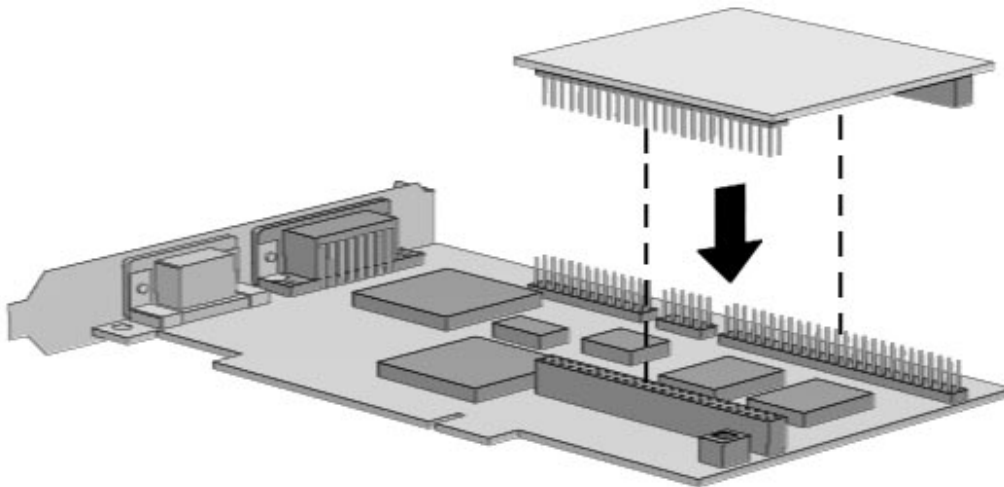


Figure 5-24. *Installing a WRAM Upgrade Module on the Graphics Board*

5. Replace the graphics controller board in the same expansion slot, securing it with the previously removed screw.
6. Replace the system unit cover.
7. Turn on the computer and start the Windows program.
8. Select the Display icon in the Compaq Utilities group box in Windows NT 3.51 or Windows 3.1, or the Display icon in Windows 95, to take advantage of the additional display modes now available with the upgraded memory. Follow the instructions on the screen.
9. Test the system (optional) using the Computer Checkup (TEST) utility. Refer to Chapter 2, "Troubleshooting."

5.1.11.2 Cirrus Logic 5446 Graphics Controller

To install additional memory onto the Cirrus Logic 5446 Graphics Controller board, complete the following steps:

1. Perform preparation procedures described in Section 5.1.3.
 2. Remove the system unit cover (Section 5.1.6).
 3. Remove the expansion board (Section 5.1.8).
 4. Place the graphics board on a flat surface and install the upgrade module.
- ✎ Ensure that all pins on the connector are properly aligned to avoid damaging the memory module and/or the graphics controller.

If you are removing a memory module, rock the module gently while pulling it up.

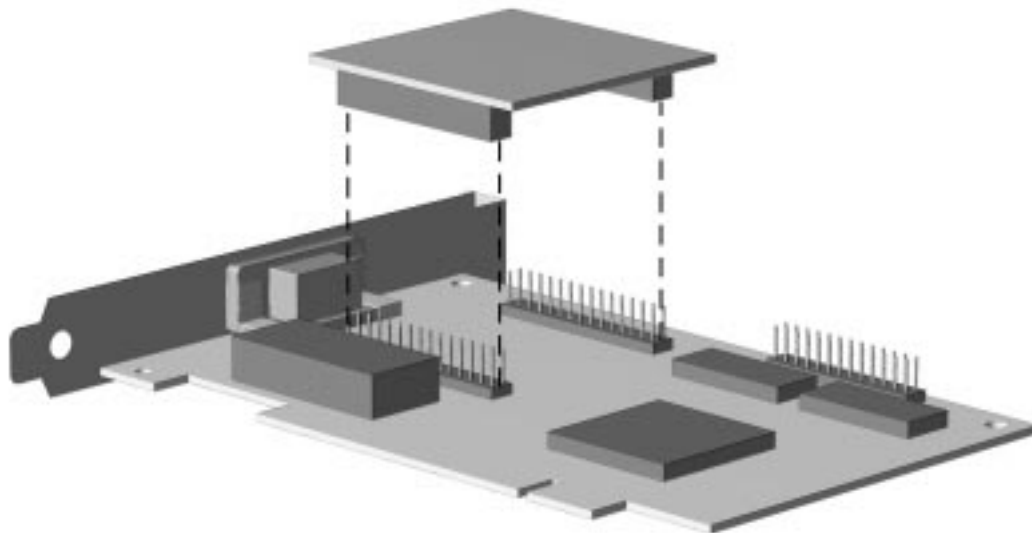


Figure 5-25. *Installing a Memory Upgrade Module on the Cirrus Logic Graphics Board*

5. Replace the graphics controller board in the same expansion slot, securing it with the previously removed screw.
6. Replace the system unit cover.
7. Turn on the computer and start the Windows program.
8. Select the Display icon in the Compaq Utilities group box in Windows NT 3.51 or Windows 3.1, or the Display icon in Windows 95, to take advantage of the additional display modes now available with the upgraded memory. Follow the instructions on the screen.
9. Test the system (optional) using the Computer Checkup (TEST) utility. Refer to Chapter 2, “Troubleshooting.”

5.1.12 Riser Board

To remove the riser board, complete the following steps:

1. Perform the preparation procedures described in Section 5.1.3.
2. Remove the system unit cover (Section 5.1.6).
3. Remove all expansion boards (Section 5.1.8).
4. Remove the two screws that secure the riser board to the riser brace.
5. Tilt the riser board slightly away from the riser brace and pull up.

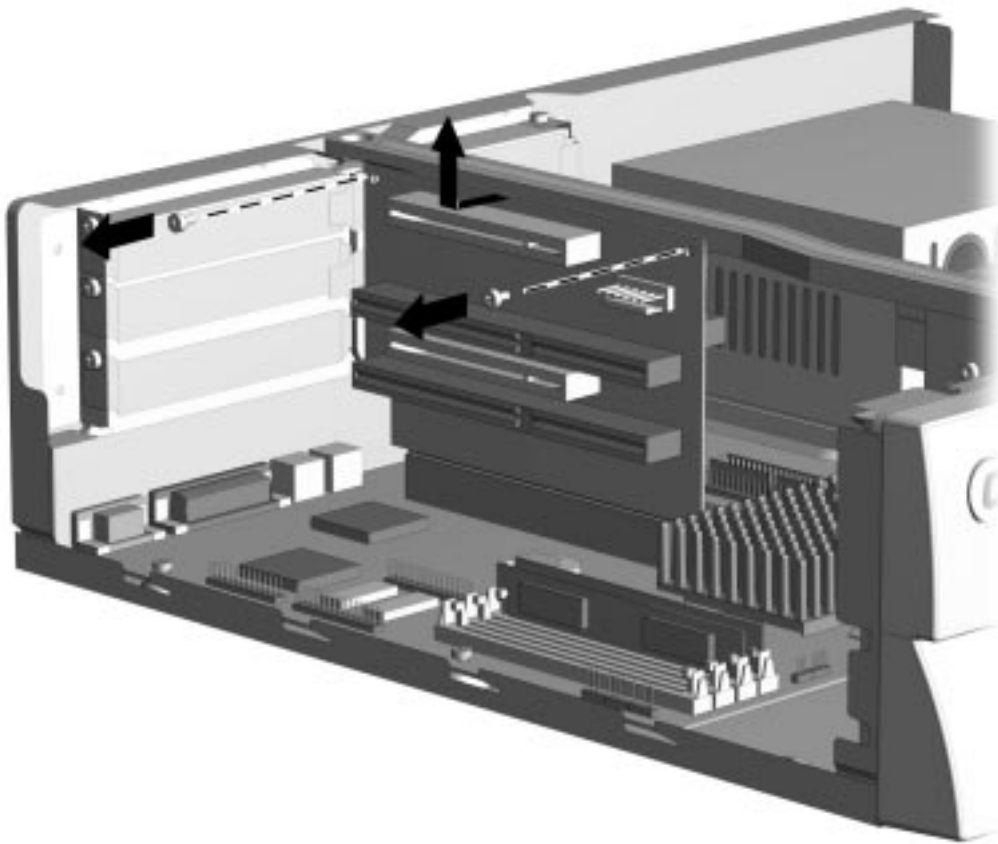


Figure 5-26. *Removing the Riser Board*

To replace the riser board, reverse the above procedure.

5.1.13 Riser Brace

The riser brace should only be removed from the computer if it has been damaged.

To remove the riser brace, complete the following steps:

1. Perform the preparation procedures in Section 5.1.3.
2. Remove the system unit cover (Section 5.1.6).
3. Remove the expansion boards (Section 5.1.8)
4. Remove the riser board (Section 5.1.12).
5. Remove the two screws that secure the riser brace to the chassis and lift the brace straight up.

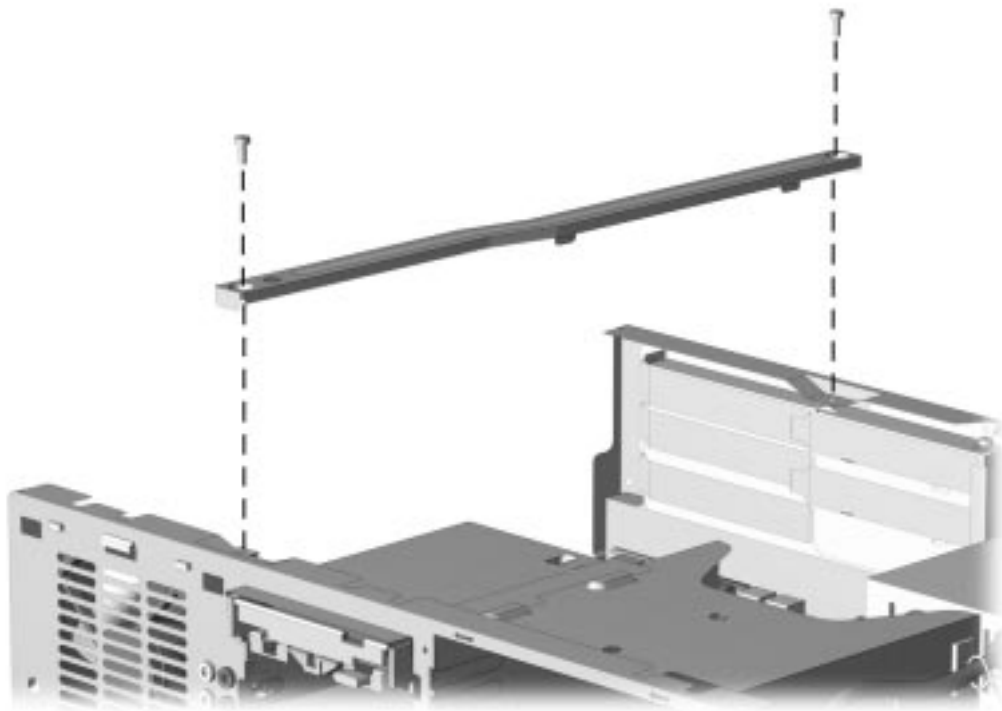



Figure 5-27. Removing the Riser Brace

To install the riser brace, reverse the above procedures.

5.1.14 System Board

To remove the system board, complete the following steps:

1. Perform the preparation procedures described in Section 5.1.3.
2. Remove the system unit cover (Section 5.1.6).
3. Remove all expansion boards (Section 5.1.8).
4. Remove the riser board (Section 5.1.12).

 It is not necessary to remove the riser brace to remove the system board.

If a replacement external battery is installed on the system board, do not unplug the battery from the system board connector. Unplugging the external battery erases CMOS. Remove the external battery from the hook-and-loop fastener on the drive cage and leave it attached to the system board (Section 5.11).

5. Disconnect any cables plugged into the system board.

6. Remove the screws securing the system board to the chassis

There are four screws securing the Pentium-based system and five screws securing the Pentium Pro-based system board in the chassis.

7. Slide the system board out of the chassis.

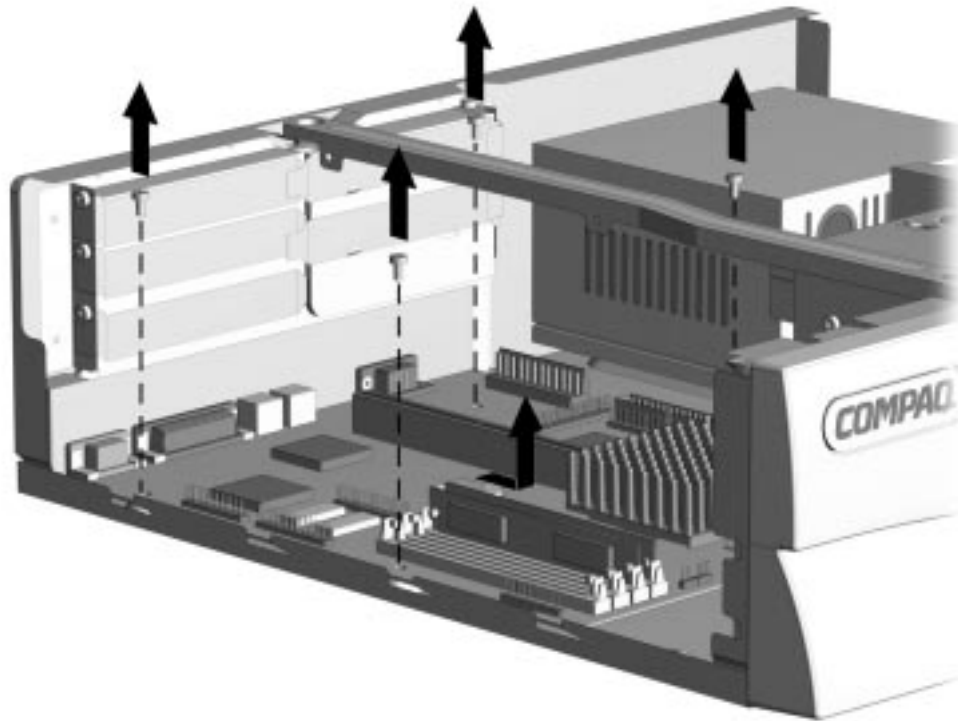


Figure 5-28. Removing the Desktop System Board

To install a new system board, reverse the above procedure.

5.1.15 Front Bezel Assembly

When removing or installing the power supply or any mass storage device, you must first remove the front bezel.

5.1.15.1 Front Bezel

The front bezel is mounted to the computer cover with release latches that are integrated into the bezel. To remove the front bezel, complete the following steps.

1. Perform the preparation procedures described in Section 5.1.3.
2. Remove the system unit cover as described in Section 5.1.6.
3. From inside the chassis, push the release latches ❶ in and push the bottom of the bezel out and away from the chassis to release the bezel at those points.
4. Slide the desktop bezel up ❷ from the bottom of the chassis.
5. Separate the bezel from the chassis.

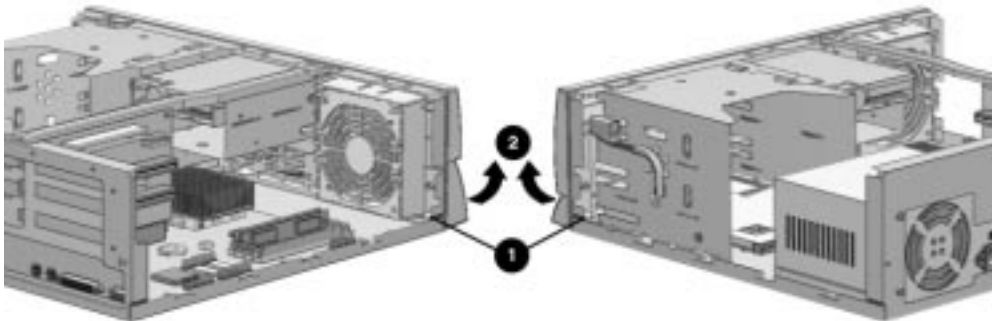


Figure 5-29. Removing the Front Bezel

To replace the front bezel, reverse the above steps, taking care to properly position the hinge points and the release latches before pushing the bezel back into the chassis.

5.1.15.2 Power Button

To remove the power button, complete the following steps:

1. Perform the preparation procedures described in Section 5.1.3.
2. Remove the system unit cover as described in Section 5.1.6.
3. Remove the front bezel as described in Section 5.1.15.1.
4. Hold the front system unit cover in one hand with the inside surface towards you.

5. Pinch the two tabs of the power button together and slip the button out of the front of the bezel. The spring will follow the button out of the housing.

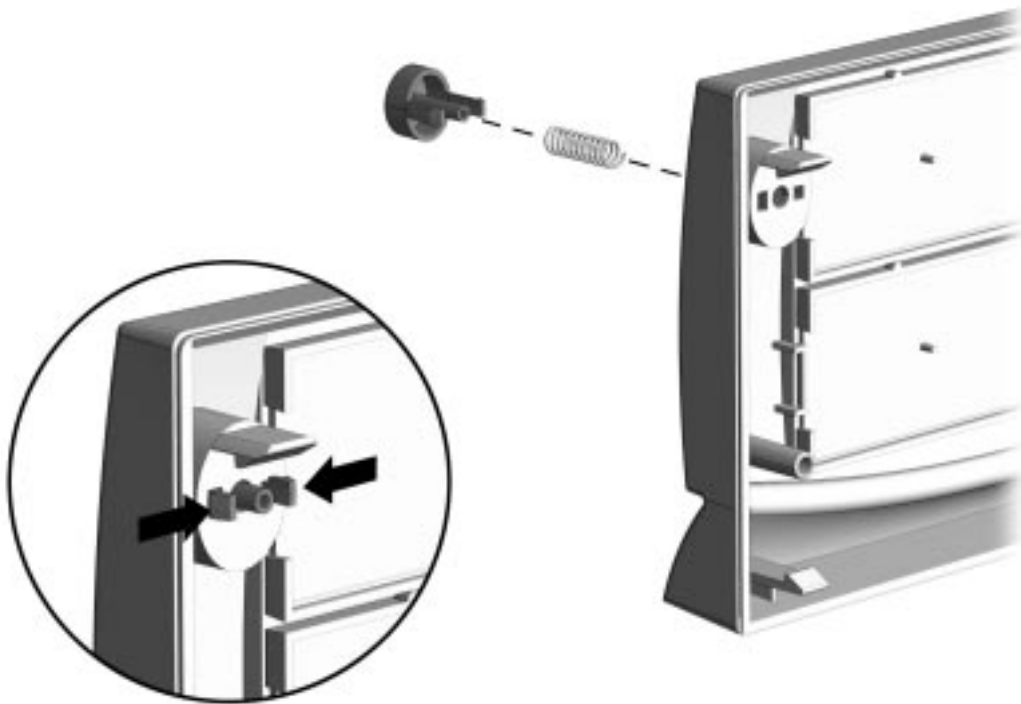


Figure 5-30. Removing the Power Button.

To replace the power button, reverse the above steps.

5.1.15.3 Bezel Blank

To remove the bezel blank, complete the following steps:

1. Perform the preparation procedures described in Section 5.1.3.
2. Remove the system unit cover as described in Section 5.1.6.
3. Remove the front bezel as described in Section 5.1.15.1.

4. Lay the front bezel face down onto a protected work surface. Grasp the tab on the right of the bezel blank and push it to the left.
5. Rotate the bezel blank up and out of the front bezel.

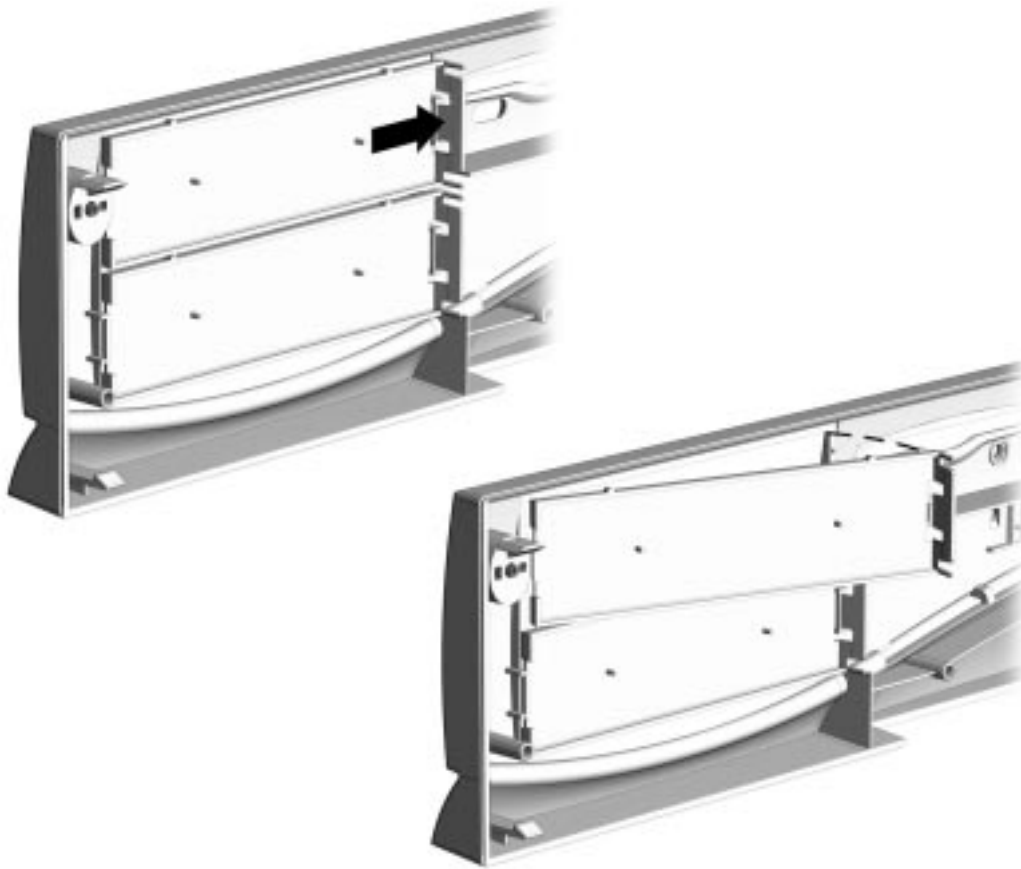


Figure 5-31. *Removing the Bezel Blank*

To reinstall the bezel blank, reverse the above procedure.

5.1.16 Compaq Logo

The Compaq logo is secured to the front bezel with adhesive. If the original logo is still installed and it is necessary to replace it, complete the following steps:

1. Remove the system unit cover as described in Section 5.1.6.
2. Remove the front bezel (Section 5.1.15.1).
3. From the inside of the front bezel, use a small screwdriver at the hole shown in the figure to push the logo out of the front bezel.
4. Use a clean cloth to clean the recessed area in the front bezel where the logo is to be installed.
5. Remove the protective cover from the back of the replacement logo and press it into place.

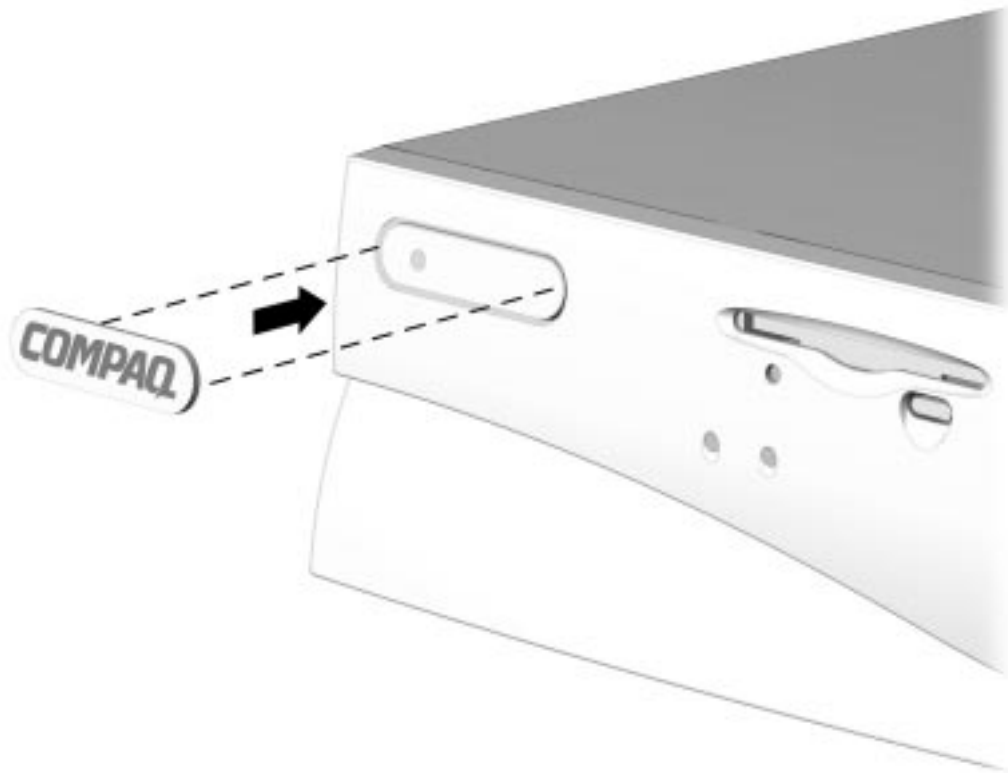


Figure 5-32. *Installing the Compaq Logo*

If the original logo is missing, complete steps four and five to replace the logo without removing the unit cover assembly.

5.1.17 Power Supply

To remove the power supply, complete the following steps:

1. Perform preparation procedures described in Section 5.1.3.
2. Remove the system unit cover (Section 5.1.6).
3. Remove the front bezel (Section 5.1.15.1).
4. From outside the chassis, remove the screw that attaches the power switch and its bracket to the front of the chassis.
5. From inside the chassis, pull the power switch and its bracket free from the chassis.

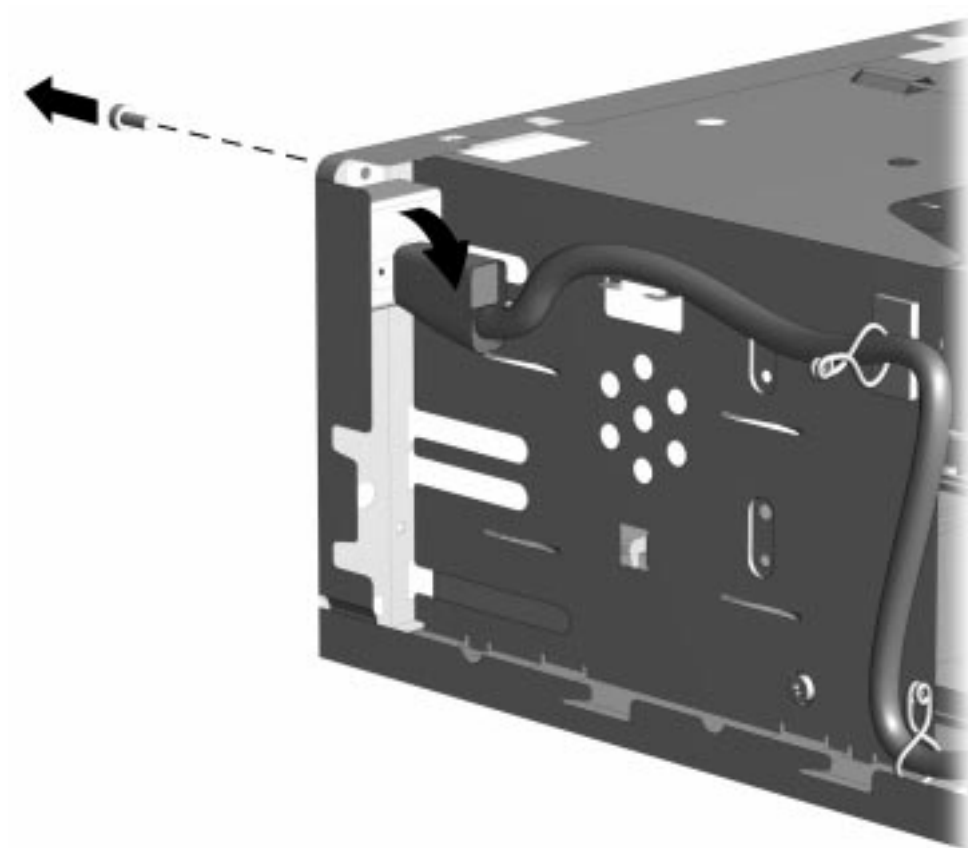


Figure 5-33. Removing the Power Supply Switch and Bracket

✎ To facilitate reassembly, note the orientation of each cable connector and the routing of each cable before you remove it.

6. Disconnect all power cables from the mass storage devices (Section 5.1.18).

7. Remove the three screws that secure the power supply to the back of the chassis.

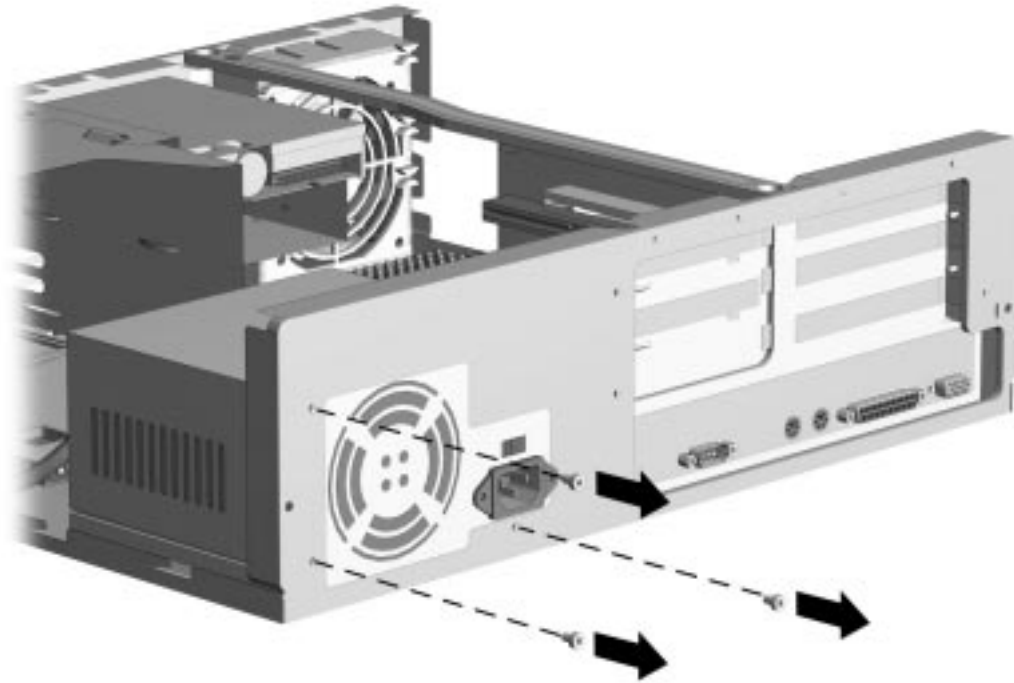


Figure 5-34. Removing the Power Supply Screws from the Rear of the Chassis

8. From inside the chassis, remove the two screws at the front of the power supply that attach it to the chassis.

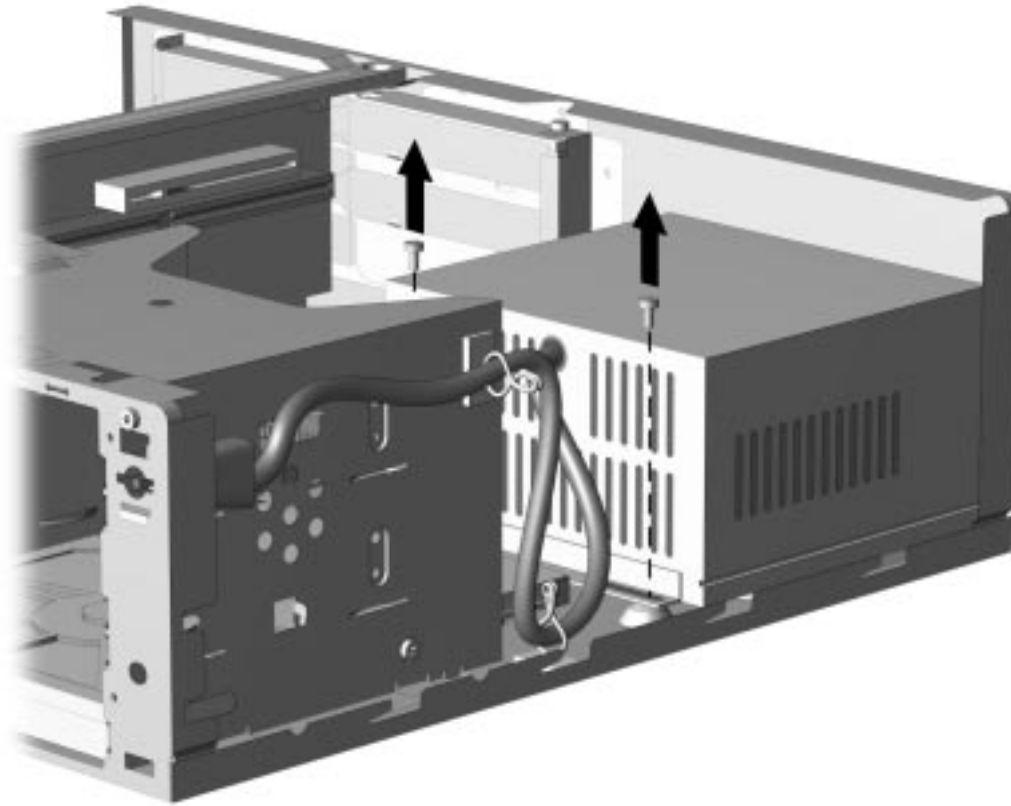


Figure 5-35. Removing the Screws Securing the Power Supply Inside the Chassis

9. Pull the power supply out of the chassis.

- ✎ The power supply is used for both the desktop and minitower personal computers and is spared with the switch mounting bracket. Install the bracket in the same orientation on the power supply and switch assembly being replaced. The bracket is held in place with two T-10 screws.

To replace the power supply assembly, reverse the previous procedure.

5.1.18 Mass Storage Devices

This section discusses removal and replacement procedures for the mass storage devices that are supported on the Compaq Deskpro 2000 Series of Personal Computers.

Drive Positions

The Compaq Deskpro 2000 Series of Personal Computers supports up to five drives internally. The drive bays and their functions are:

- ❶ One external standard 3.5-inch third-height diskette drive
- ❷ One external 5.25-inch half-height bay for optional CD-ROM drive, diskette drive, tape drive, or hard drive
- ❸ One external 5.25-inch half-height bay for optional CD-ROM drive, diskette drive, tape drive, or hard drive
- ❹ One 3.5-inch internal bay for hard drive
- ❺ One 5.25-inch internal bay for hard drive

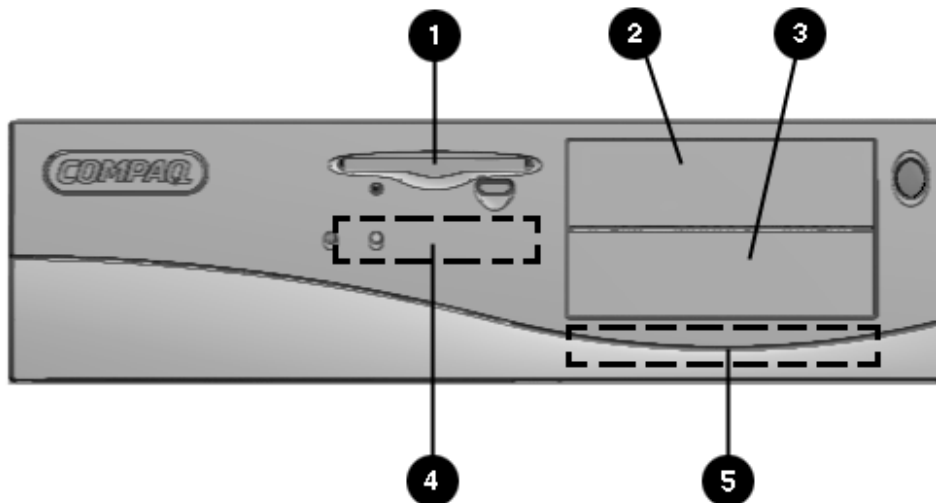


Figure 5-36. Five Drive Bay Positions on the Desktop Computer

✍ The computer will have either a 5.25-inch hard drive installed in location ❺ or a 3.5-inch hard drive installed in location ❹.

Adding an Additional Drive

For information on installing an additional hard drive or CD-ROM drive using cable-select technology, refer to Appendix C, “Hard Drives.”

5.1.18.1 3.5-Inch Wide Drive Bays

The computer has two 3.5-inch third-height drive bays, one of which is occupied by the diskette drive.

To remove a 3.5-inch drive from the 3.5-inch wide drive bay, complete the following steps:

1. Perform preparation procedures described in Section 5.1.3.
2. Remove the system unit cover (Section 5.1.6).
3. Remove the front bezel (Section 5.1.15.1).
4. Disconnect the interconnect cables from the back of the drive.

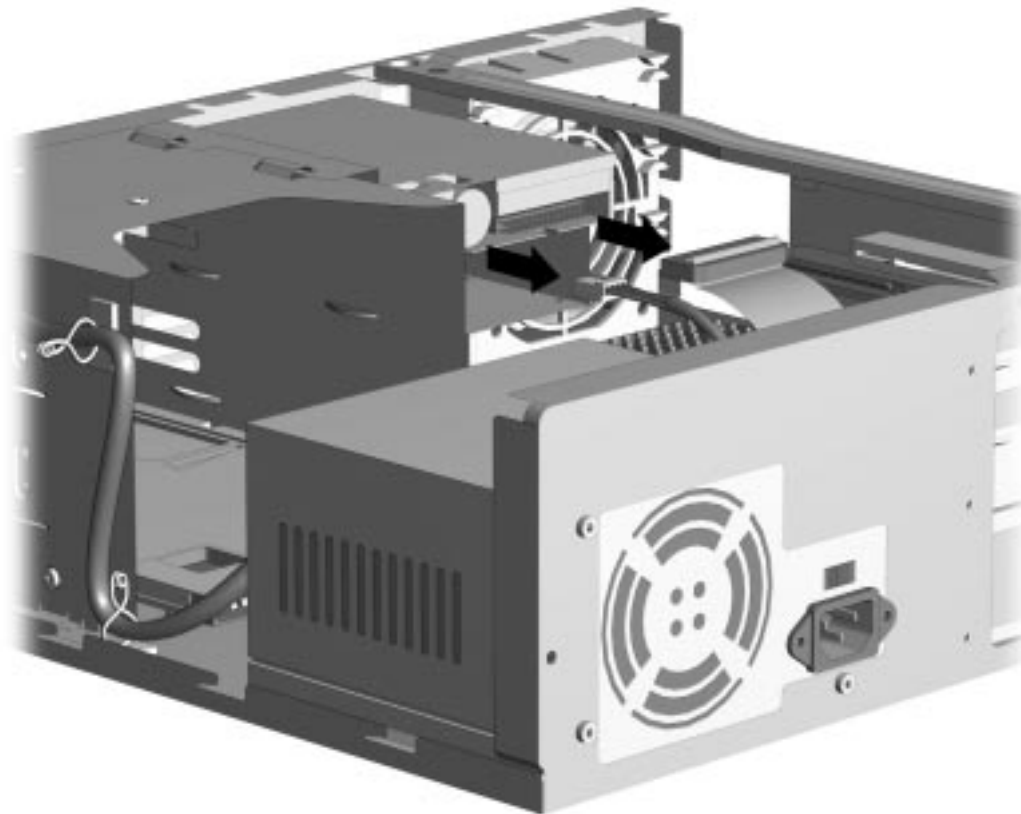


Figure 5-37. *Disconnecting the Signal and Power Cables from the 3.5-Inch Diskette Drive*

5. Remove the single screw on the left of the drive that secures the drive in the chassis.
6. Pull the 3.5-inch drive straight out of the chassis.

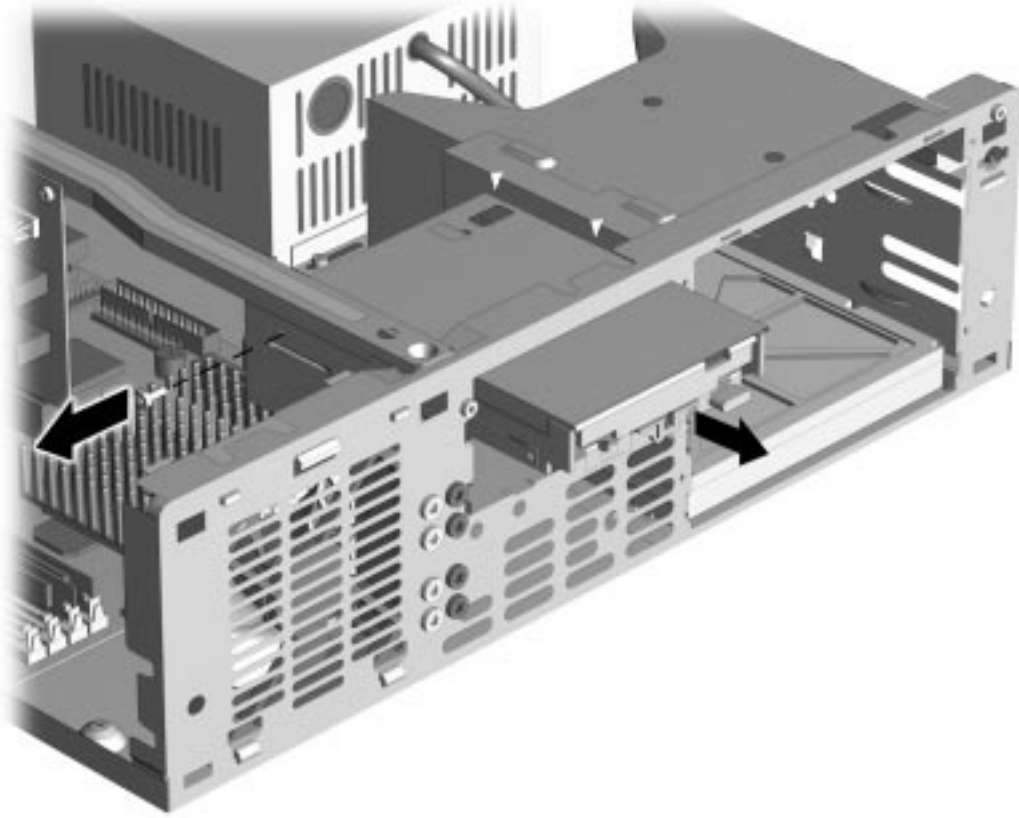


Figure 5-38. Removing the 3.5-Inch Diskette Drive

When replacing this drive, transfer the two wafer screws from the old drive to the new one. There is one wafer screw on each side of the drive at the front.

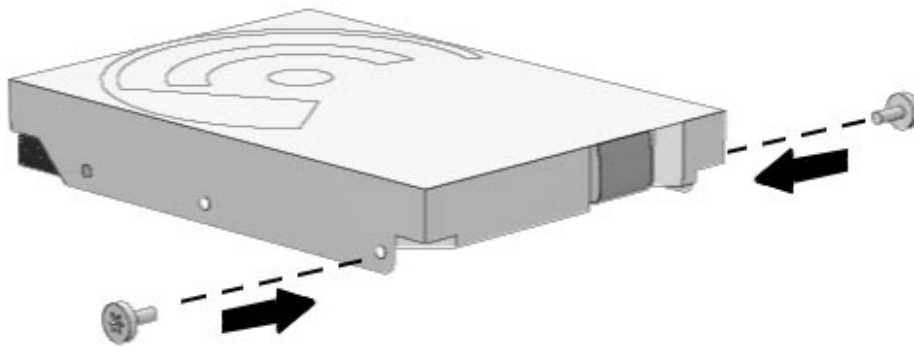


Figure 5-39. *Installing the Wafer Screws*

✎ Wafer screws act as guides for the drive and take the place of drive rails.

To replace the 3.5-inch drive, reverse the above procedure.

Always ensure that the cables are placed in their proper locations during the reassembly process.



CAUTION: When servicing this computer, ensure that cables are placed in their proper locations during the reassembly process. Improper cable placement can damage the computer.



CAUTION: Use only 3/16-inch or 5-mm long screws as guide screws. Longer screws can damage the internal components of the drive.

5.1.18.2 5.25-Inch Wide Drive Bays

The 5.25-inch drive bays may be occupied by hard drives, CD-ROM, PD-CD, or tape drives.

Before beginning the removal procedure, ensure that all removable media have been removed from the drive.



CAUTION: Before beginning this procedure, turn off the power to the computer.

If you need to manually eject a CD from the CD-ROM drive, insert a metal rod that is approximately 1.2 mm in diameter and at least 35 mm in length (1/16 x 1 3/8 inches) into the manual eject hole and push firmly. A straightened paper clip works well. The tray will come out 1/4 to 1/2 inch. Pull the tray out by hand until the CD can be removed.

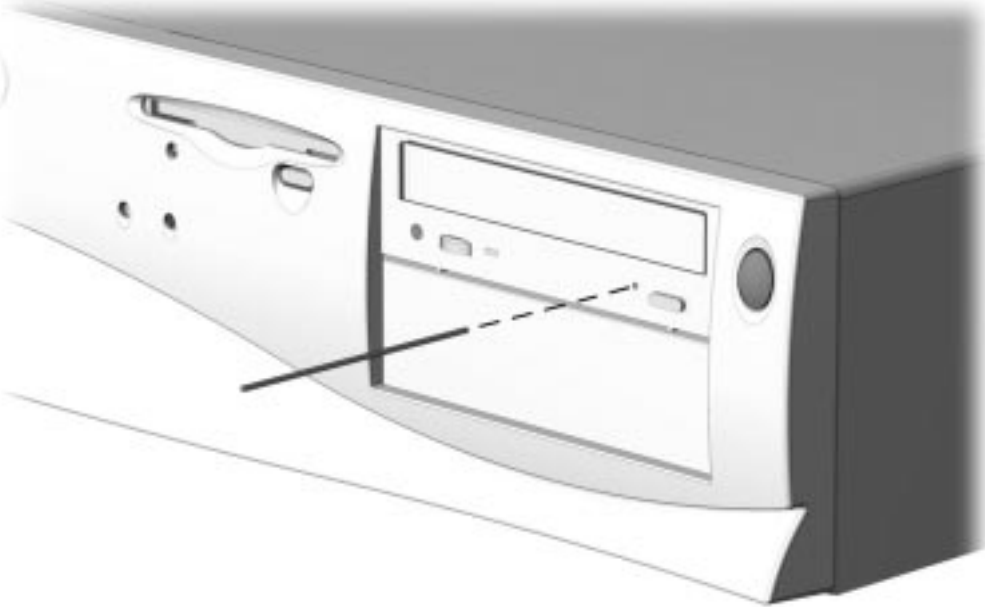


Figure 5-40. *Manually Ejecting a Compact Disc From a Minitower Computer*

To remove a drive from a 5.25-inch wide bay, complete the following steps:

1. Perform preparation procedures described in Section 5.1.3.
2. Remove the system unit cover (Section 5.1.6).
3. Remove the front bezel (Section 5.1.15.1).

4. Disconnect all cables from the back of the drive.

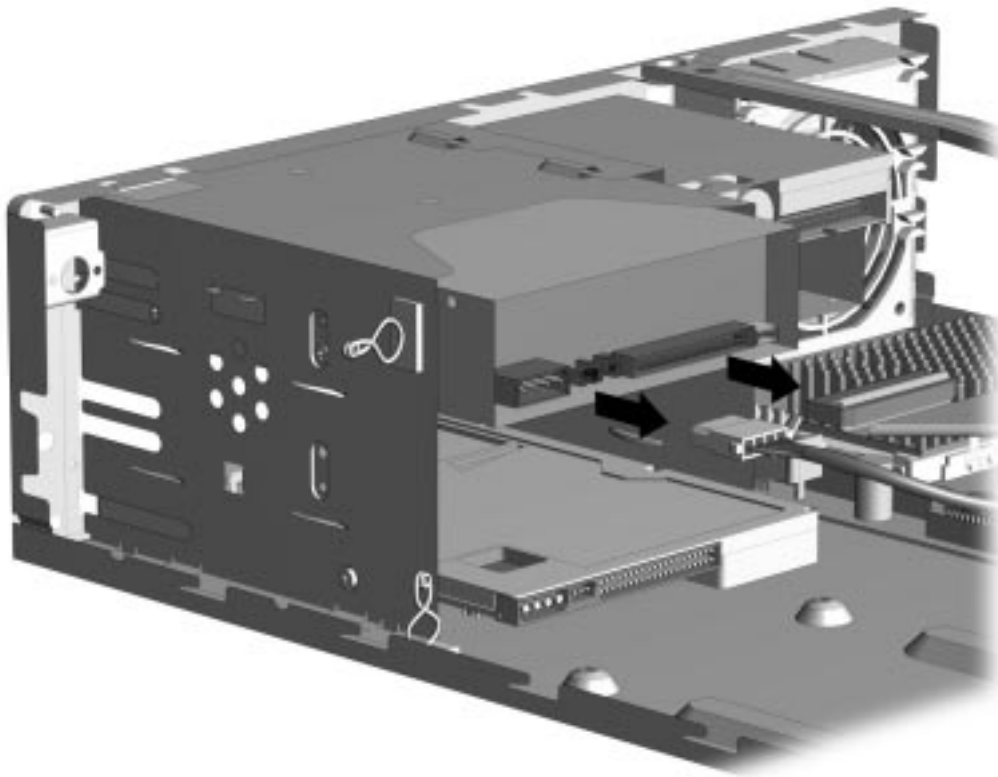


Figure 5-41. Disconnecting the Signal and Power Cables from the CD-ROM Drive

7. Remove the screw on the right side of the drive that secures the drive in the chassis.
8. Pull the drive straight out of the chassis.

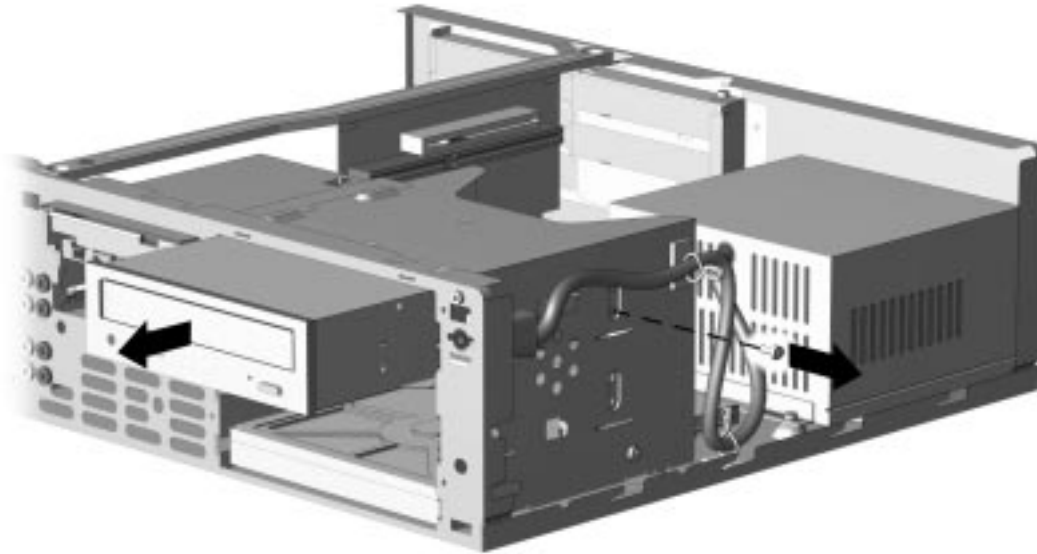


Figure 5-42. *Removing the CD-ROM Drive*

To replace the 5.25-inch wide drive bay device, complete the following steps:

1. Transfer the two wafer screws from the old drive to the new one.
2. Reverse the above procedures.

5.1.18.3 Installing a New Drive

When installing a new drive into the computer you should use either the wafer screws provided with the option kit or the extra U.S. and metric screws stored in the front of the computer frame for this purpose. Select the appropriate screws for the application.

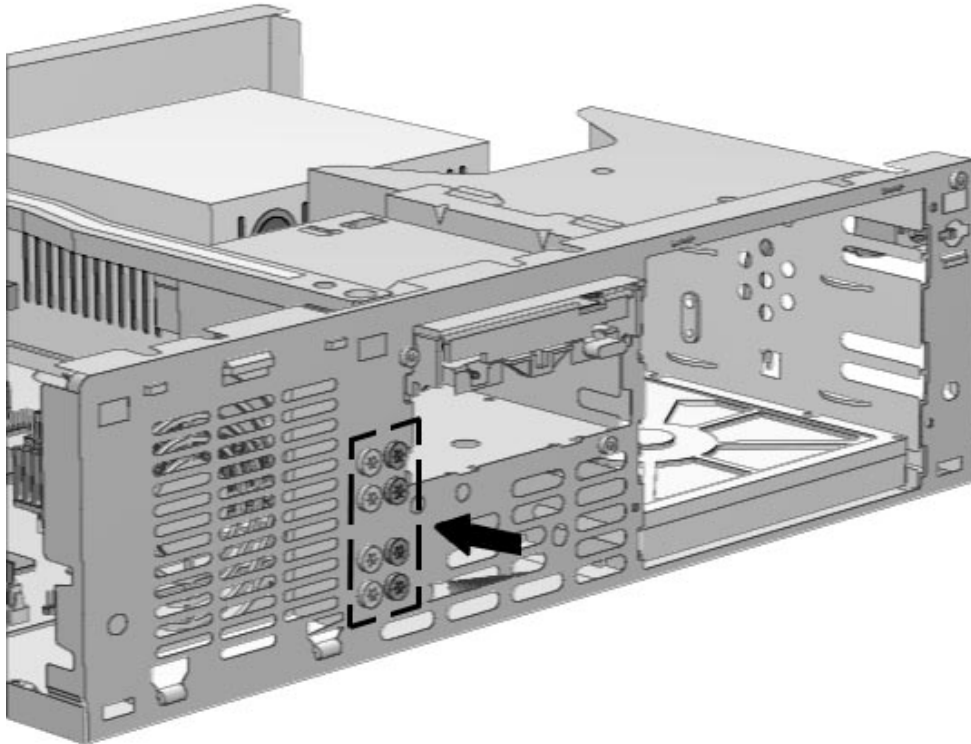


Figure 5-43. Locating the Flanged Screws

✎ Metric screws have a black finish while U.S. screws have a silver finish.

If you are installing a 3.5-inch drive into a 3.5-inch wide drive bay or a 5.25-inch drive into a 5.25-inch wide drive bay, continue with step 1.

If you are installing a 3.5-inch drive into a 5.25-inch wide drive bay, skip to step 4.

1. Install one wafer screw on each side of the front of the drive.

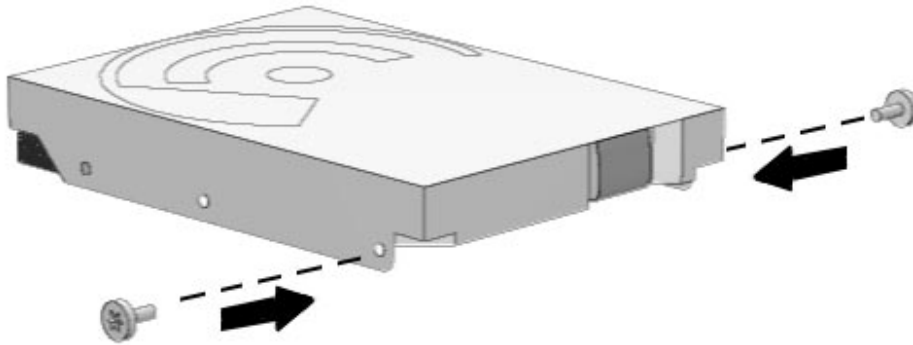


Figure 5-44. *Installing the Wafer Screws into the Drive*

2. Install the drive assembly into the drive bay. If this is a 3.5-inch drive, the retaining screw is installed on the left side of the drive bay. If this is a 5.25-inch drive, the retaining screw is installed on the right side of the drive bay.

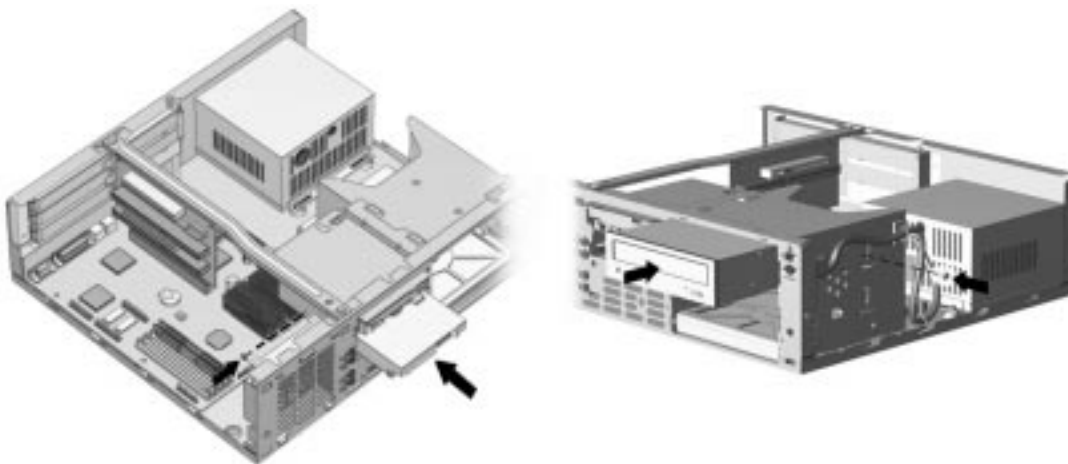


Figure 5-45. *Installing the Drive*

3. Continue with step 8.
4. If you are installing a 3.5-inch diskette drive, use bracket number 243230-001 which comes with a preinstalled bezel. This bracket is available from your Compaq dealer or service provider.

If you are installing a 3.5-inch hard drive, use bracket number 243231-001. This bracket is available from your Compaq dealer or service provider.

5. Place the 3.5-inch drive into the bracket.
6. Insert two screws into the bracket holes on each side of the bracket to secure the drive.

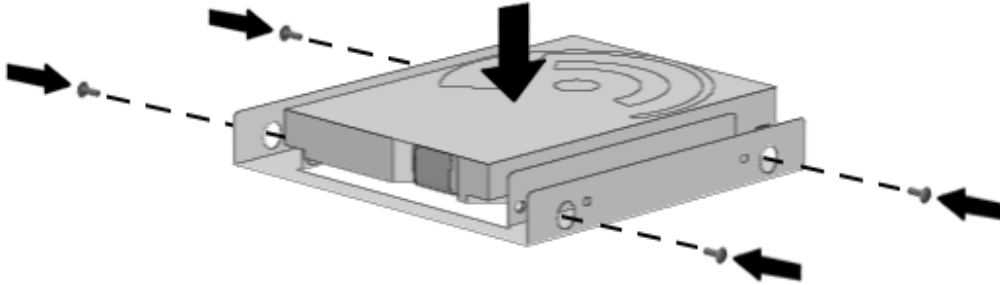


Figure 5-46. *Placing the Hard Drive and Inserting Four Screws into the Bracket*



CAUTION: Use only 3/16-inch or 5-mm long screws as guide screws. Longer screws can damage the internal components of the drive.

7. Install two wafer screws from step 1. Insert one on each side of the bracket. These are guide screws are used to align the bracket in the drive bay.

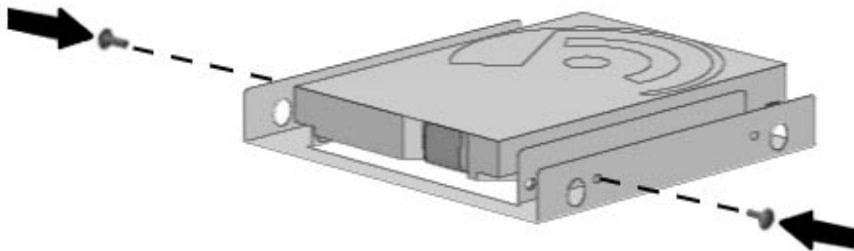


Figure 5-47. *Inserting Two Flanged Screws into the Bracket*

8. Install the drive assembly into the drive bay positioning the guide screws into the tabs on either side of the drive bay.

9. Secure the drive with the screw packed in the option kit.

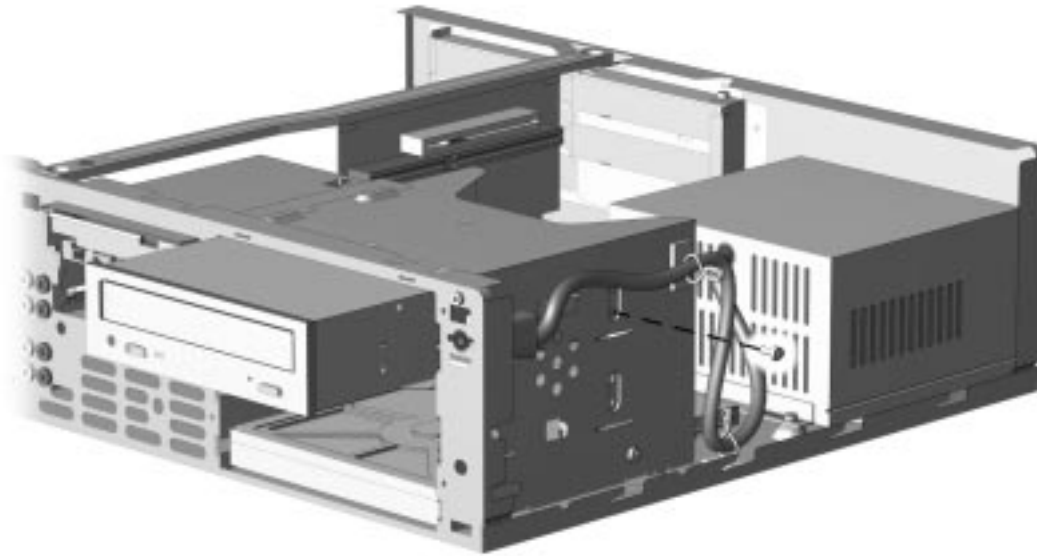


Figure 5-48. *Installing the Hard Drive and Securing it with a Retaining Screw*

10. Connect the drive cables.

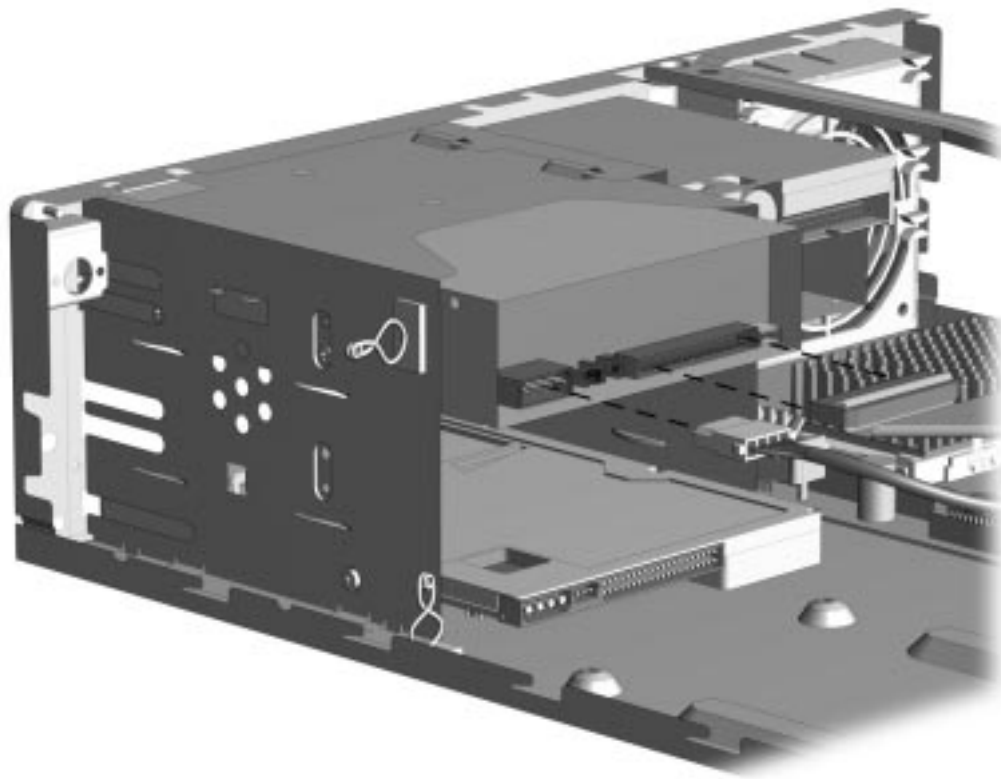


Figure 5-49. *Connecting the Signal and Power Cables*

11. Remove the bezel blank from the front bezel (Section 5.1.15.3).
12. Install the front bezel.
13. Install the system unit cover.
14. The system will automatically recognize a hard drive sold by Compaq and will automatically reconfigure the computer. If you have installed a third party hard drive, you will need to run Computer Setup to reconfigure the computer. Refer to Chapter 7, "Using Compaq Utilities," for information on running Computer Setup.
15. Test the system (optional) using the Computer Checkup (TEST) utility. Refer to Chapter 2, "Troubleshooting."

The figure below illustrates the recommended header connection for the CD-ROM drive ribbon cable.

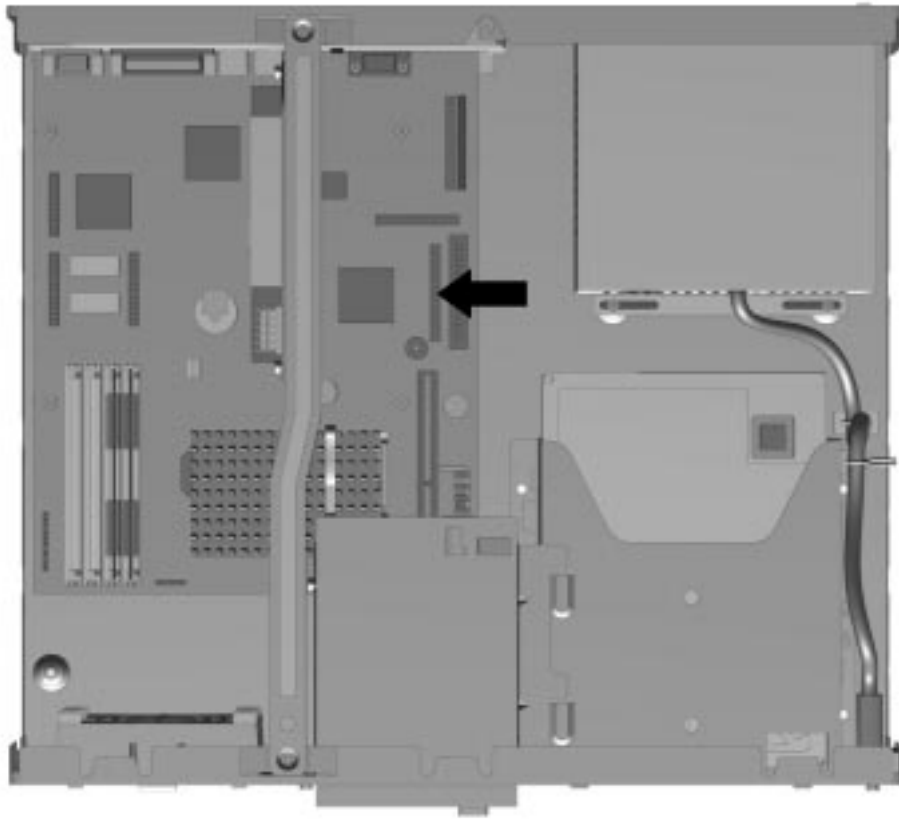


Figure 5-50. Ribbon Cable Position for the CD-ROM Drive (Desktop)

5.1.19 Expansion Board Guide

To remove the expansion board guide from the desktop computer, complete the following steps:

1. Perform preparation procedures described in Section 5.1.3.
2. Remove the system unit cover (Section 5.1.6).
3. Remove all expansion boards that are on the outboard side of the computer (Section 5.1.8.2).
4. Remove the front bezel (Section 5.1.15.1).
5. Unsnap the plastic clip on top and rotate the board guide down, then pull out.

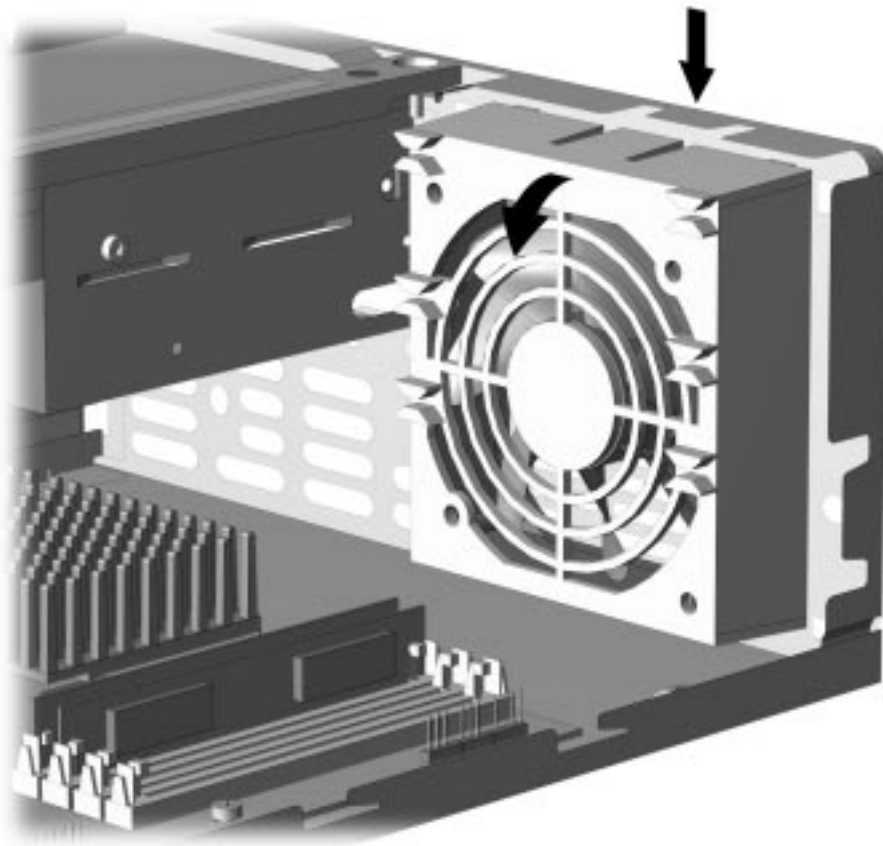


Figure 5-51. Removing the Desktop Expansion Board Guide

To replace the expansion board guide, reverse the previous procedure.

5.1.20 Drive Cage

To remove the drive cage from the computer chassis, complete the following steps:

1. Perform the preparation procedures described in Section 5.1.3.
2. Remove the system unit cover (Section 5.1.6).
3. Remove the front bezel (Section 5.1.15.1).
4. Remove the two screws that secure the drive cage to the chassis.
5. Slide the drive cage towards the inside of the chassis to release the latches.
6. Lift the assembly up.

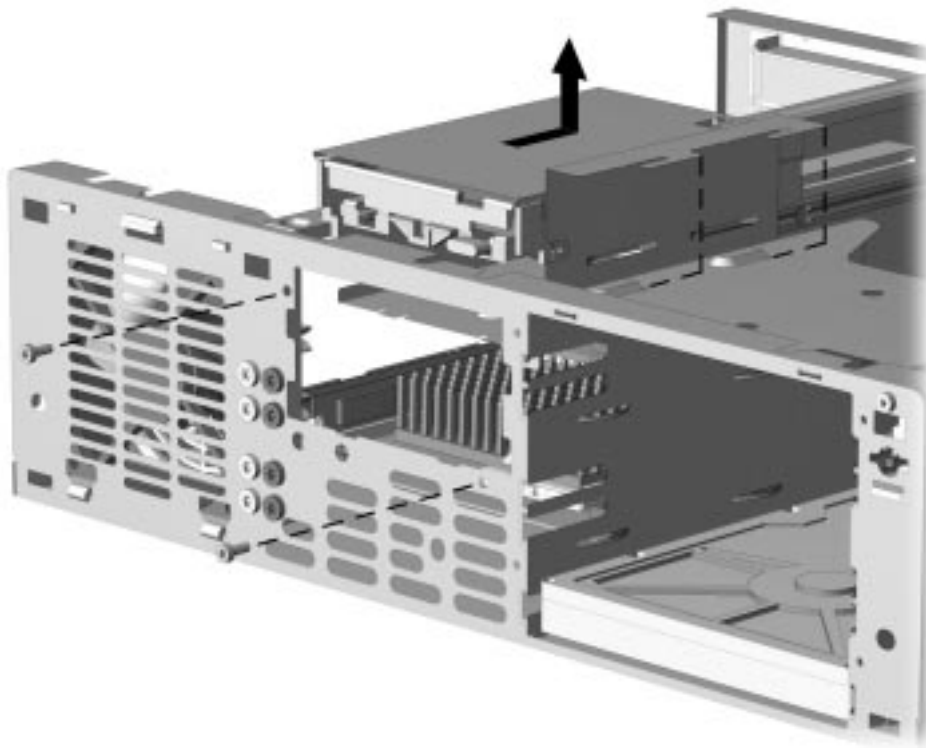


Figure 5-52. *Removing the Drive Cage*

To install the drive cage, reverse the above procedure.

5.1.21 LED Cable

To remove the LED cable, complete the following steps:

1. Perform the preparation procedures described in Section 5.1.3.
2. Remove the access panel (Section 5.1.6).
3. Remove the riser brace (Section 5.12).
4. Disconnect the cable from the connection on the system board.

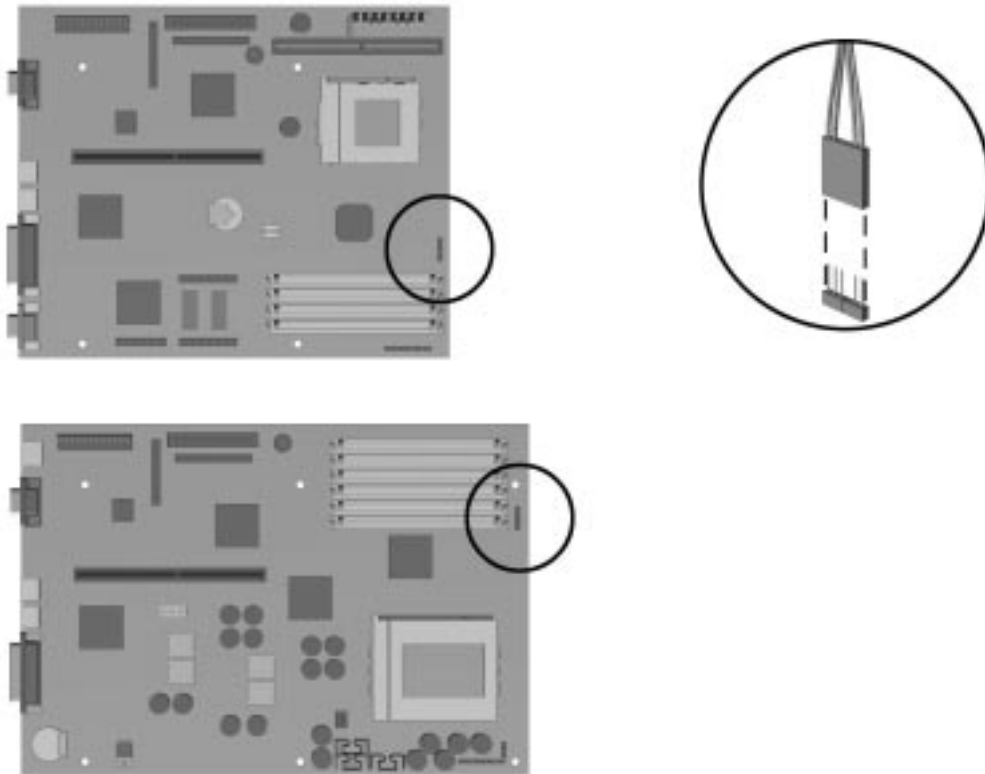


Figure 5-53. Removing the LED Cable From the Pentium (Top) and Pentium Pro (Bottom) System Boards

✎ The connector is keyed to ensure proper installation.

5. Remove the LED end of the cable from the front of the chassis by gently pulling on the cable while at the same time pushing the end of the LED from the front of the chassis.

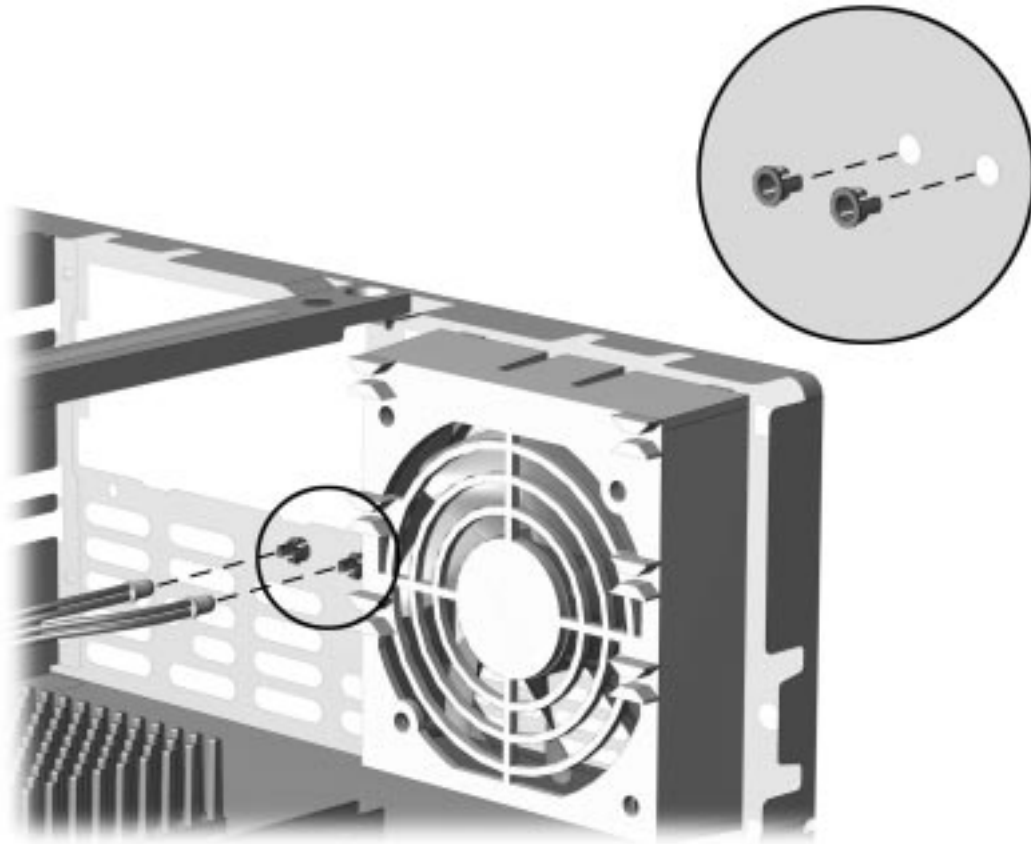


Figure 5-54. Removing the LED Cable From the Front of the Chassis

To install the LED cable, reverse the above steps.

5.2 Minitower Instructions

5.2.1 Serial Number

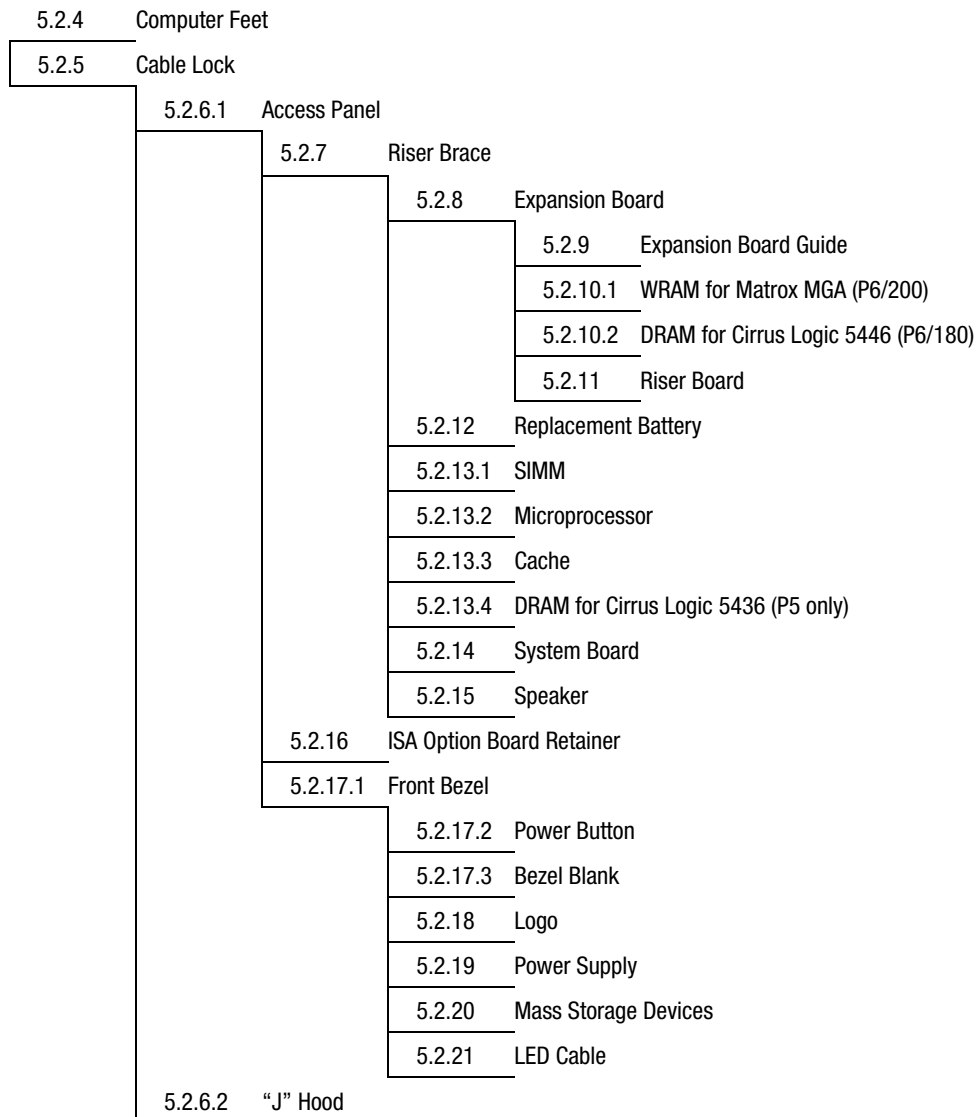
The computer serial number should be provided to Compaq whenever requesting information or ordering spare parts. The serial number is located on the right side of the hood, toward the front **1** and on the rear of the chassis above the expansion slots **2**.



Figure 5-55. Serial Number Location

5.2.2 Disassembly/Assembly Sequence Chart

The disassembly/assembly sequence chart below is for the Compaq Deskpro 2000 Minitower Personal Computer.



5.2.3 Preparation for Disassembly

See Chapter 4, “Removal and Replacement Preliminaries,” for initial procedures. To prepare the computer for the removal and replacement procedures, complete the following steps:

1. Remove any diskette, compact disc, or tape from the computer.
2. Turn off the computer and any peripheral devices that are connected to the computer.



CAUTION: The computer power switch should be turned off before you disconnect any cables.

3. Disconnect the power cord from the electrical outlet and then from the computer.
 4. Disconnect all peripheral device cables from the computer.
- ✎ During disassembly, label each cable as you remove it, noting its position and routing.

5.2.4 Feet

Four rubber feet are mounted to the underside of the base pan. No parts have to be removed to gain access to the feet. The replacement feet have an adhesive surface and are shipped with a protective strip in place. Remove the protective strip from the replacement feet before installation.



Figure 5-56. *Installing the Feet*

5.2.5 Cable Lock

To install the cable lock provision, complete the following steps:

1. Remove one thumbscrew from the rear of the computer. Use a coin or flat-bladed screwdriver, if needed.
2. Position the bottom part of the cable lock provision over the screw hole and install the screw provided in the cable lock option kit.
3. Cover the screw with the top part of the cable lock provision.
4. Install a lock (not provided) to secure the top part of the cable lock provision.

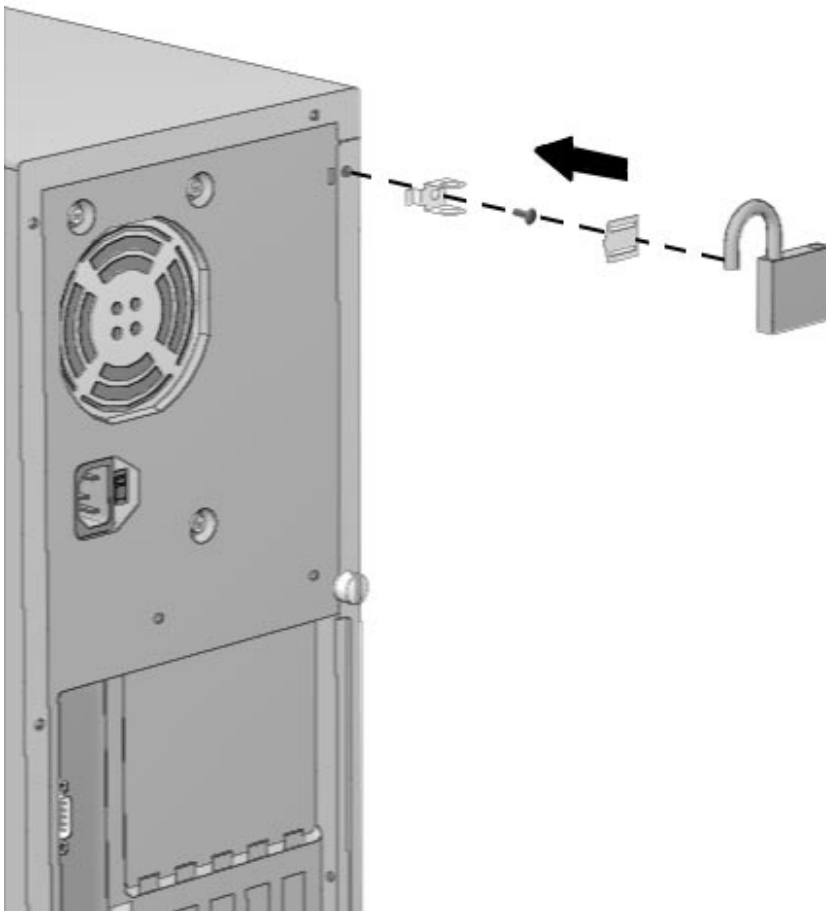


Figure 5-57. Cable Lock Provision on the Minitower Computer

To remove the cable lock provision, reverse the above procedure.

5.2.6 Exposing the Chassis

5.2.6.1 Access panel

To remove the access panel, complete the following steps:

1. Perform preparation procedures described in Section 5.2.3.
2. Remove the three cover thumbscrews from the back of the computer. You may need a coin or flat-bladed screwdriver to loosen the screws.

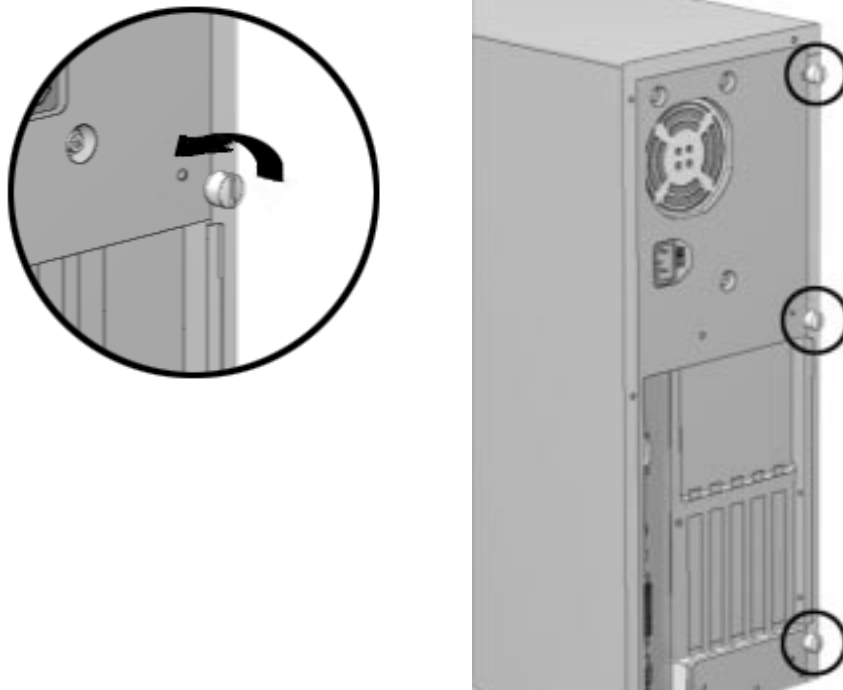


Figure 5-58. Loosening the Minitower Thumbscrews

3. Grasp the rear of the cover, pull back about two to three inches, pivot the top of the access panel out about one-inch, and lift the cover from the computer.

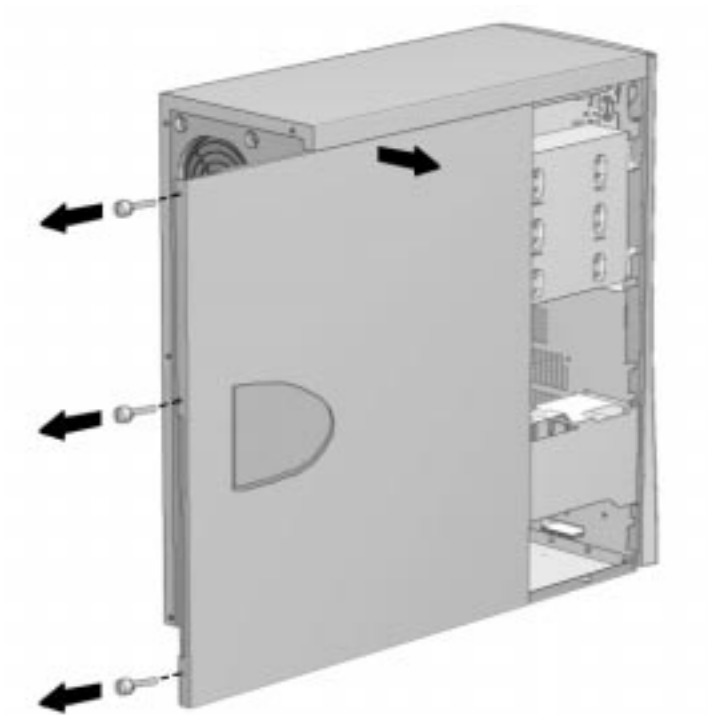


Figure 5-59. Removing the Minitower Access Panel

5.2.6.2 Minitower “J” Hood

It is not necessary to remove the “J” hood unless it is damaged.

To remove the “J” hood, complete the following steps:

1. Perform the preparation procedures described in Section 5.2.3.
2. Remove the four screws securing the “J” hood to the chassis.
3. Slide the “J” hood back, and then lift it from the chassis.

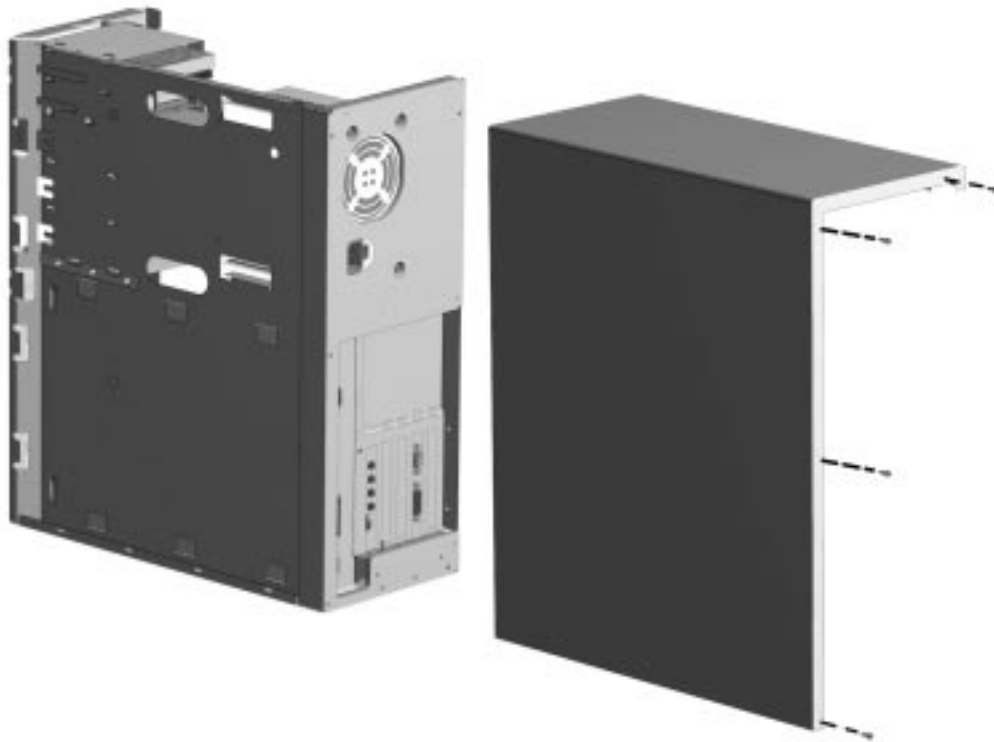


Figure 5-60. Removing the “J” Hood

To replace the “J” hood, reverse the above procedure.

5.2.7 Riser Brace

Before an expansion board can be installed or replaced, you must remove the riser brace that holds the expansion boards. Follow these steps to remove the riser brace:

1. Perform preparation procedures described in Section 5.2.3.
2. Remove the access panel (Section 5.2.6.1).
3. With the computer laying on its side, grasp the expansion board brace at both ends and pull it out of the computer chassis. Use care when guiding the assembly out of the unit to prevent damaging the boards.

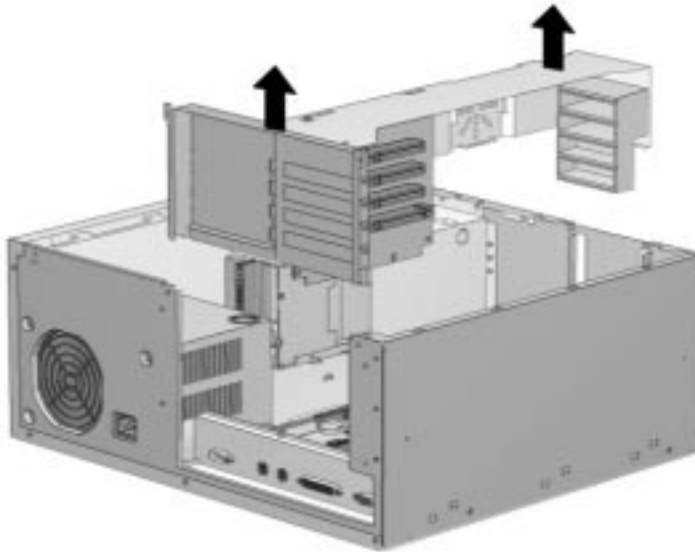


Figure 5-61. Removing the Riser Brace

To replace the riser brace, reverse the above procedure.

- ⚠ When reinstalling the riser brace, fully seat the riser board attached to the cage into the system board socket to ensure complete electrical contact.

Test the computer (optional) using the Computer Checkup (TEST) utility (see Chapter 2, "Troubleshooting.")

5.2.8 Expansion Board

The Compaq Deskpro 2000 Series Minitower Personal Computer contains five expansion slots, which are located on the riser board.

- ❶ Two PCI (Peripheral Component Interconnect) expansion slots
- ❷ One PCI/ISA (Industry Standard Architecture) shared expansion slot
- ❸ Two ISA expansion slots

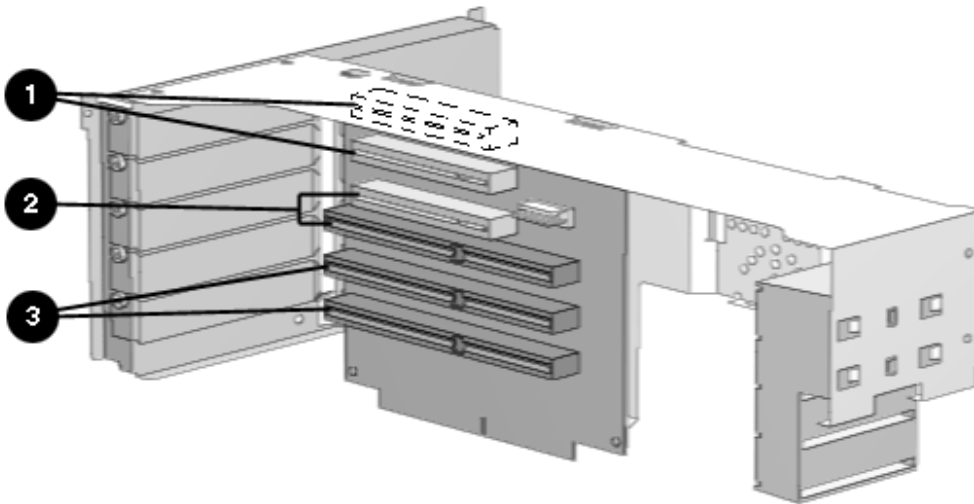


Figure 5-62. Five Expansion Slots in the Riser Board

To remove an expansion board, complete the following steps:

1. Perform preparation procedures described in Section 5.2.3.
2. Remove the access panel (Section 5.2.6.1).
3. Remove the riser brace as described in section 5.2.7.
4. If cables are attached to the expansion board, disconnect them.

5. Remove the expansion board screw from the riser brace.
6. Slide the expansion board out of the expansion slot.

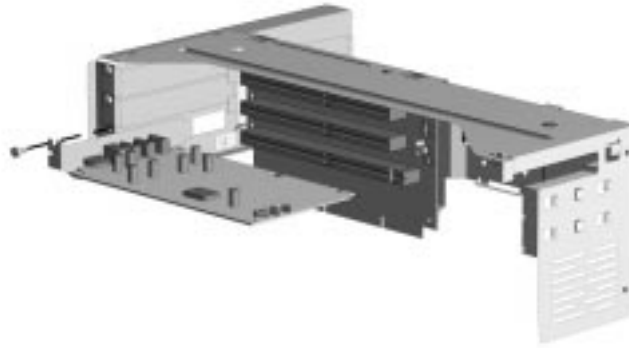


Figure 5-63. *Removing and Expansion Board*

To install an expansion board, reverse the above procedure.

- ✎ If you are installing an expansion board for the first time in a slot, remove the retaining screw and the expansion board slot cover before installing the board.

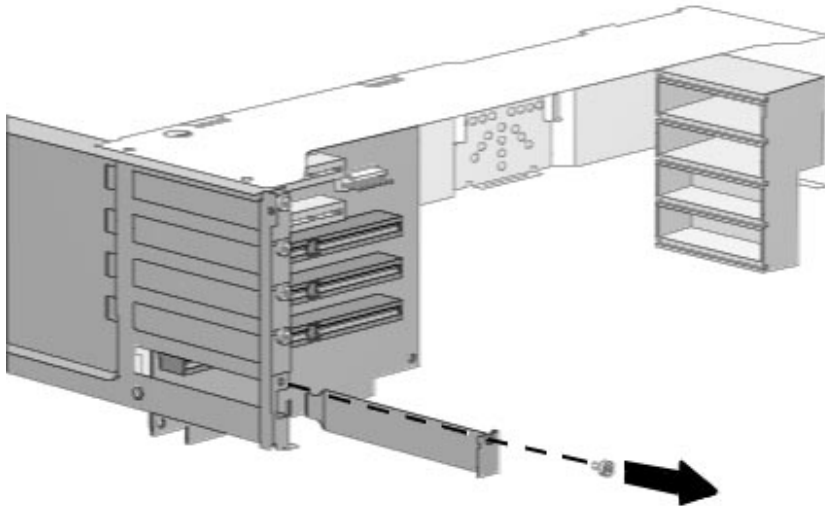


Figure 5-64. *Removing the Screw and Expansion Slot Cover*

5.2.9 Expansion Board Guide

To remove the expansion board guide from the minitower computer, complete the following steps:

1. Perform preparation procedures described in Section 5.2.3.
2. Remove the access panel (Section 5.2.6.1).
3. Remove the expansion brace (section 5.2.7).
4. Remove the expansion boards (Section 5.2.8).
5. Slide the board guide to the right and unsnap it from the front of the chassis.

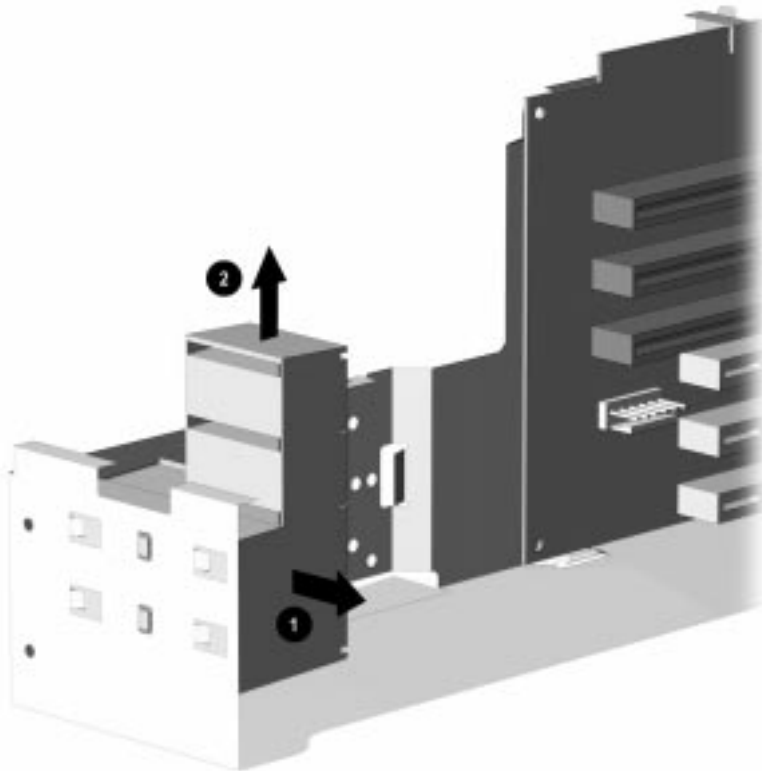


Figure 5-65. Removing the Minitower Expansion Board Guide

To replace the expansion board guide, reverse the above procedure.

5.2.10 Expansion Board Components

5.2.10.1 Matrox MGA Millennium Graphics Controller

To install additional WRAM onto the Matrox MGA Millennium Graphics board, complete the following steps:

1. Perform preparation procedures described in Section 5.1.3.
 2. Remove the access panel (Section 5.2.6.1).
 3. Remove the expansion board (Section 5.2.8).
 4. Place the graphics board on a flat surface and install the upgrade module.
- ✎ Ensure that all pins on the connector are properly aligned to avoid damaging the memory module and/or the graphics controller.

If you are removing a memory module, rock the module gently while pulling it up.

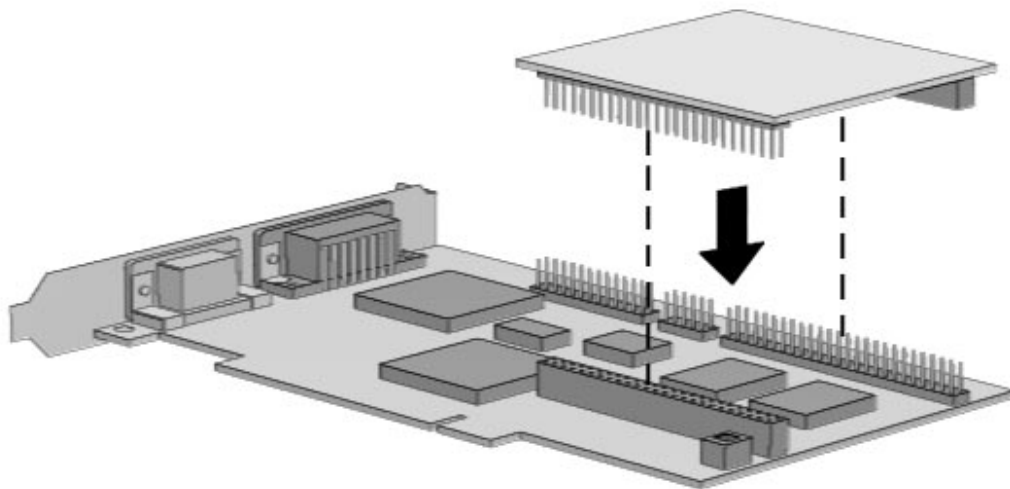


Figure 5-66. *Installing a WRAM Upgrade Module on the Graphics Board*

5. Replace the graphics controller board in the same expansion slot, securing it with the previously removed screw.
6. Replace the access panel.
7. Turn on the computer and start the Windows program.
8. Select the Display icon in the Compaq Utilities group box in Windows NT 3.51 or Windows 3.1, or the Display icon in Windows 95, to take advantage of the additional display modes now available with the upgraded memory. Follow the instructions on the screen.
9. Test the system (optional) using the Computer Checkup (TEST) utility. Refer to Chapter 2, “Troubleshooting.”

5.2.10.2 Cirrus Logic 5446 Graphics Controller

To install additional memory onto the Cirrus Logic 5446 Graphics Controller board, complete the following steps:

1. Perform preparation procedures described in section 5.2.3.
 2. Remove the access panel (section 5.2.6.1).
 3. Remove the expansion board (Section 5.2.8).
 4. Place the graphics board on a flat surface and install the upgrade module.
- ✎ Ensure that all pins on the connector are properly aligned to avoid damaging the memory module and/or the graphics controller.

If you are removing a memory module, rock the module gently while pulling it up.

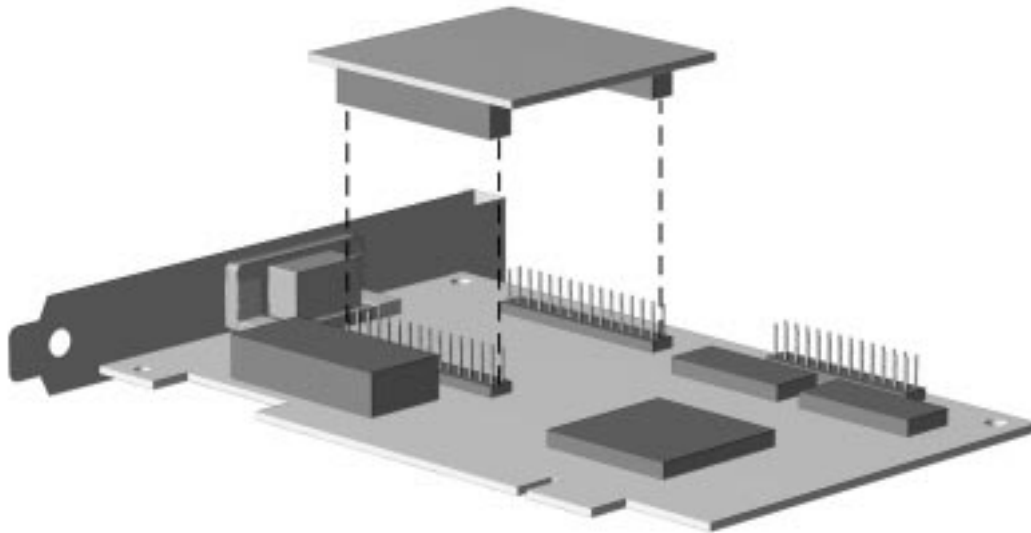


Figure 5-67. *Installing a Memory Upgrade Module on the Cirrus Logic Graphics Board*

5. Replace the graphics controller board in the same expansion slot, securing it with the previously removed screw.
6. Replace the access panel.
7. Turn on the computer and start the Windows program.
8. Select the Display icon in the Compaq Utilities group box in Windows NT 3.51 or Windows 3.1, or the Display icon in Windows 95, to take advantage of the additional display modes now available with the upgraded memory. Follow the instructions on the screen.
9. Test the system (optional) using the Computer Checkup (TEST) utility. Refer to Chapter 2, "Troubleshooting."

5.2.11 Riser Board

To remove the riser board, follow these steps:

1. Perform preparation procedures described in Section 5.2.3.
2. Remove the access panel (Section 5.2.6.1).
3. Remove all expansion boards from the riser board as described in Section 5.2.8.
4. Remove all cables attached to the riser board.
5. Remove the screws that secure the riser board to the riser brace
6. Tilt the riser board slightly away from the riser brace and pull up.

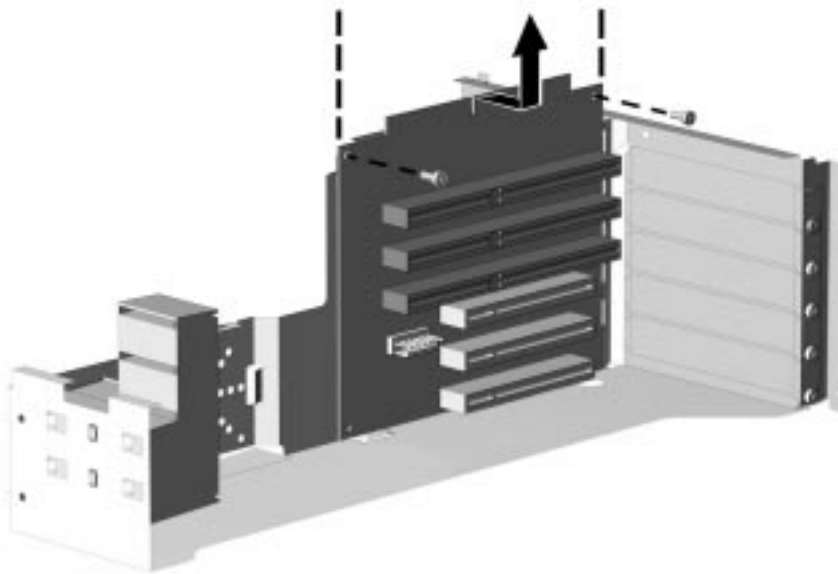


Figure 5-68. Removing the Riser Board

To replace the riser board, reverse the previous procedure, taking care to align the chassis brace tabs in the chassis notches.

5.2.12 Replacement Battery

The real-time clock battery that came with the computer is nonreplaceable and is permanently installed on the system board. Use Compaq replacement battery 160274-001 or a comparable 600-milliamp alkaline, 4.5-volt battery.

- ✎ It is important to make a set of backup diagnostics diskettes before you install a new battery.
- ✎ If a non-Compaq hard drive is installed in the computer, it is important to take the following steps before installing the battery.
 1. Run the Computer Setup utility and observe the drive type that is displayed in the System Configuration summary.
 2. If the drive type number is 65 or 66, make a note of the drive parameters. You can view these parameters by turning off the computer and then, restarting it, pressing **F10** when the square cursor appears in the upper-right corner of the screen. From the Compaq Utilities menu, select Computer Setup. Select Storage, then select Configure Fixed Disk Drive to view the parameters. It is important to record these parameters before continuing.
 3. When you have completed the battery installation, run the Computer Setup utility to reconfigure the system. Refer to Chapter 7, "Compaq Utilities."

To install the external real-time clock battery, complete the following steps:

1. Perform preparation procedures described in Section 5.2.3.
2. Remove the access panel (Section 5.2.6.1).



WARNING: The system board contains a clock/CMOS lithium battery. The lithium battery may explode if mistreated. The battery is soldered in and may not be removed. Do not abuse or disassemble. Use only replacement batteries supplied by Compaq Computer Corporation (spare part number 160274-001).

3. Connect the new battery to the pins on the E9 battery header connector.

The battery connector is keyed for proper installation.

✎ Connecting the replacement battery to the pins automatically disconnects the internal battery.

E8	E6 Passwd.	E9
Clear CMOS	5-6=ENA 6-7=DIS	Ext. Batt.

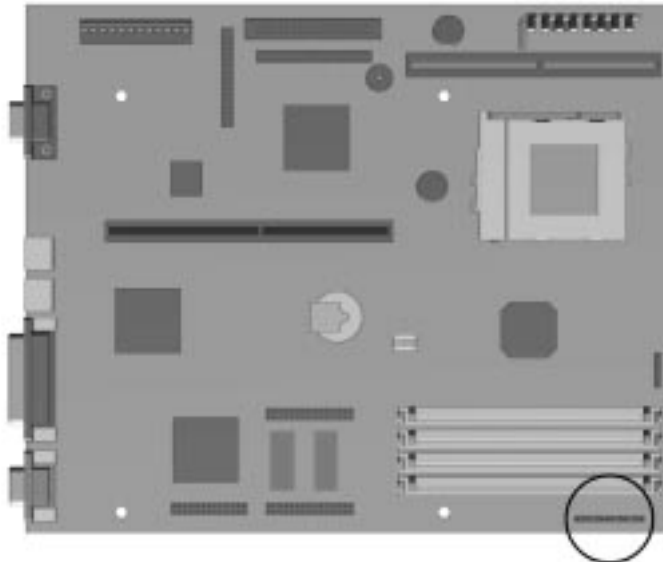


Figure 5-69. Battery Connection Location

4. Remove the backing from the adhesive on the hook-and-loop fastener strip, and attach the battery with the hook-and-loop fastener strip as shown.

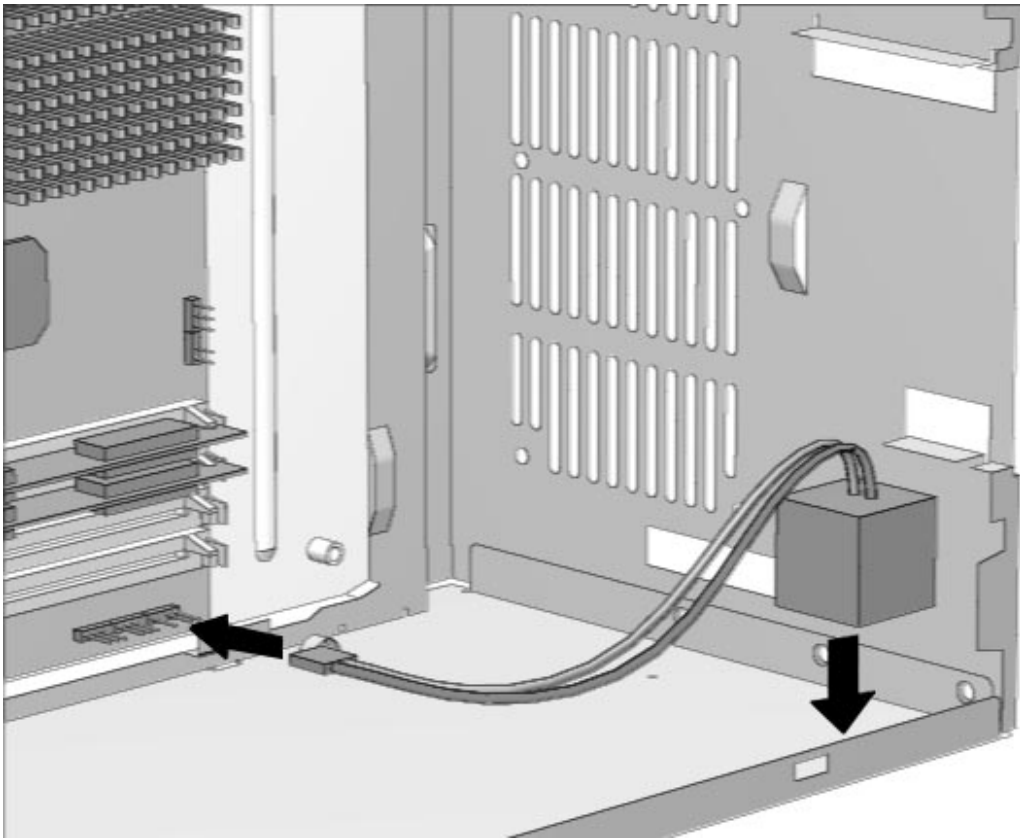


Figure 5-15 *Installing the Battery on the Minitower*

5. Replace the computer access panel.
6. Place the sticker included with your battery kit on the back of your computer above the power connector.
7. Plug in the computer and reconnect any external devices.



WARNING: This equipment is designed for connection to a grounded (earthed) outlet. The grounding type plug is an important safety feature. To avoid the risk of electrical shock or damage to the equipment, do not disable this feature.

8. Turn on the computer.
9. Run the Computer Setup utility to reconfigure the system. Refer to Chapter 7, "Compaq Utilities."

5.2.13 System Board Components

5.2.13.1 Memory Modules

You can expand computer memory by installing industry standard single inline memory modules (SIMMs) on the system board.

There are four memory sockets that can be populated when installing memory on the Pentium system board and six memory sockets on the Pentium Pro system board.

SIMMs are installed in equally matched pairs; for example, two 8-megabyte modules, two 16-megabyte modules, or two 32-megabyte modules. If you are mixing EDO and FPM DRAM, identical modules must be installed two at a time, for example, two EDO modules of the same type, speed, and size; or two FPM DRAM modules of the same type, speed, and size.

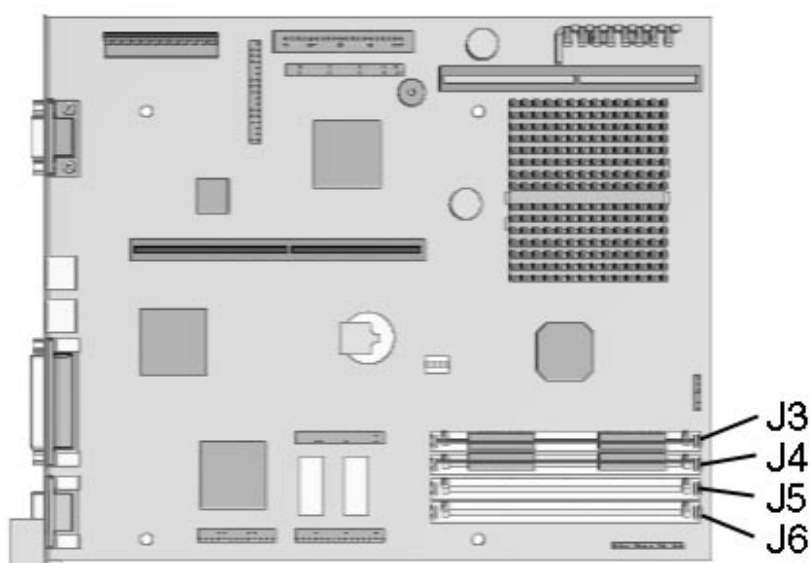


Figure 5-71. Four Memory Sockets on the Pentium-Based System Board



CAUTION: Static electricity can damage the electronic components of the computer or optional equipment. Before beginning these procedures, ensure that you are discharged of static electricity by briefly touching a grounded metal object.

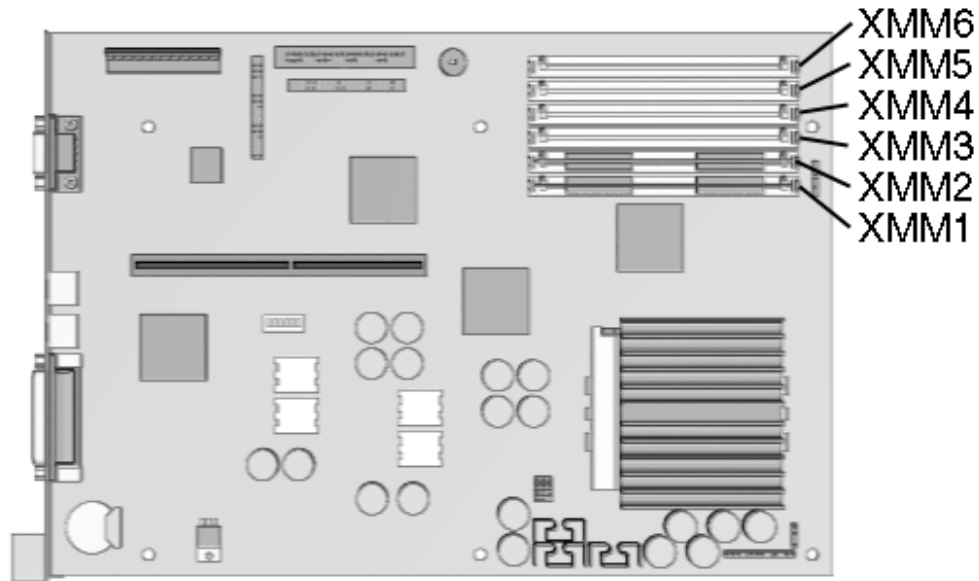


Figure 5-72. Six Memory Module Sockets on the Pentium Pro-Based System Board

Memory Upgrades		
Model	Standard	Expandable to:
Pentium-based system	8-, 16-, or 32-MB DRAM	128-MB DRAM
Pentium Pro-based system	16- or 32-MB DRAM	192-MB DRAM

CAUTION: When handling a memory module, be careful not to touch any of the contacts. Doing so may damage the module.

To install a memory module, complete the following steps:

1. Perform preparation procedures described in Section 5.2.3.
2. Remove the access panel (Section 5.2.6.1).
3. Remove the riser brace (Section 5.2.7)

4. Insert a memory module at a 45-degree angle into a memory socket on the system board.

A memory module can only be installed one way. Match the notch on the module with the tab on the memory socket. Push the module down into the socket, ensuring that the module is fully inserted and properly seated.

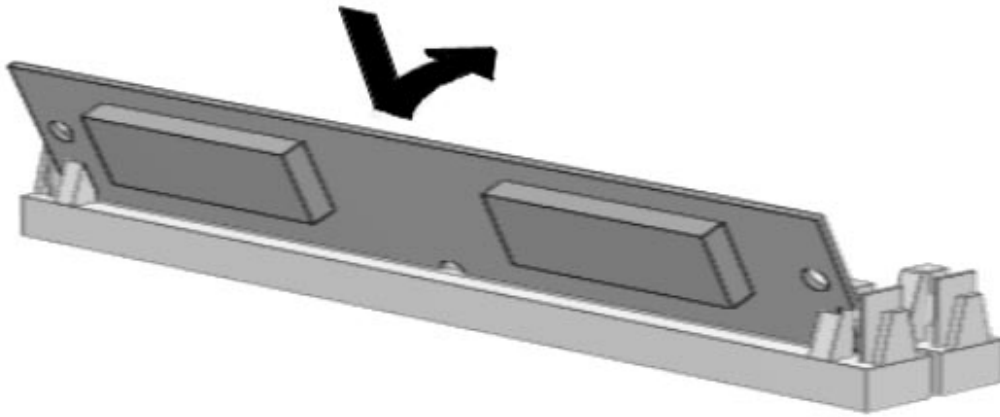


Figure 5-73. *Installing a Memory Module*

5. Rotate the module to an upright position, allowing the latches to snap into place.

6. Repeat steps 4 and 5 for each module that you want to install.

7. Replace the access panel.

8. The computer recognizes system memory upgrades and automatically reconfigures the computer. If, for some reason, the memory upgrades do not configure correctly, run Computer Setup to reconfigure the computer. Refer to Chapter 7, "Compaq Utilities," for information on running Computer Setup.

9. Test the system (optional) using the Computer Checkup (TEST) utility. Refer to Chapter 2, "Troubleshooting."

To replace a memory module, follow these steps.

1. Perform preparation procedures described in Section 5.2.3.
2. Remove the access panel (Section 5.2.6.1).
3. Remove the riser brace (Section 5.2.7).
4. Release the SIMM socket latches and rotate the module to a 45-degree position.
5. Lift the memory module out of the socket.
6. Replace the memory module as described in the in the preceding procedures.

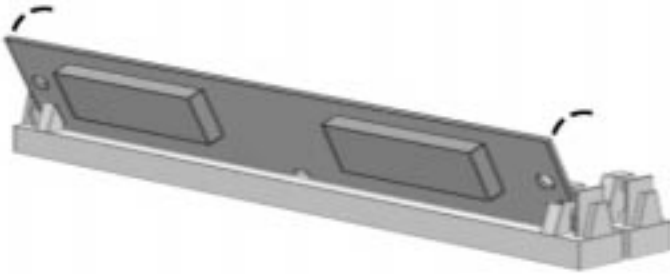


Figure 5-74. Rotating the Memory Module Upright

7. Replace the access panel.

5.2.13.2 Microprocessor

To remove the microprocessor from the system board, complete the following steps:

1. Perform preparation procedures described in Section 5.2.3.
2. Remove the access panel (Section 5.2.6.1).



WARNING: To reduce the risk of personal injury from hot surfaces, allow the internal system components to cool before touching.



CAUTION: When replacing a Pentium processor, you must release the heatsink retaining clip before you pull the ZIF socket handle. This clip engages the processor socket to hold the heatsink in place.

3. Remove the riser brace (Section 5.2.7).
4. Remove the heatsink retaining clip ❶ by pressing down on the clip's extended tab until it releases from the safety catch.
5. Lift the heatsink ❷ off the processor.
6. Release the original processor from the socket by pulling the handle on the ZIF socket out ❸ and upward ❹.
7. Lift the processor ❺ out of the socket.

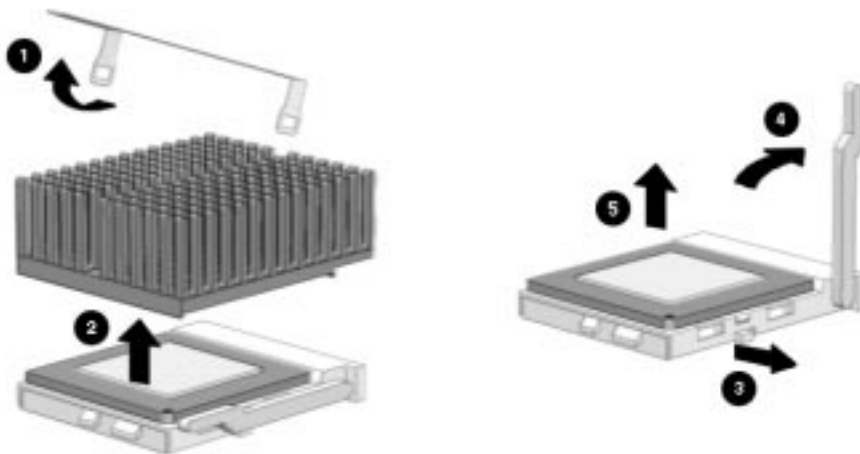


Figure 5-75. Removing the Microprocessor from the System Board




CAUTION: When replacing the processor, be sure that the clipped corner of the processor (location of Pin 1) is aligned with the triangular area of the ZIF socket (hinged corner). Failure to do so could result in burning out both the processor and the system board.

Depending on the model, you can upgrade the processor by replacing the processor currently installed with a processor upgrade.

Processor Supported Upgrades	
Base processor	Can be upgraded to
P5/100	P5/120, P5/133, P5/166, and P5/200
P5/120	P5/133, P5/166, and P5/200
P5/133	P5/166 and P5/200
P5/166	P5/200
P6/180	P6/200



CAUTION: Installing the processor upgrade incorrectly may cause damage to the processor board. Compaq recommends that you have a Compaq authorized reseller or service provider install the processor upgrade. If you plan to install it yourself, read all the instructions carefully before you begin.

 The handle on the ZIF socket in your computer may not look identical to the handle shown in the drawing. All handle types perform the same function.

To install a processor, complete the following steps:

1. Install the processor by lowering it into the ZIF socket. Ensure that pin 1 on the processor lines up with pin 1 on the ZIF socket.
2. Push the handle on the ZIF socket back into place to secure the processor.

3. If the processor has a raised center, install thermal pad number 243226-001 on top of the processor before installing the heatsink.

If the process or has a flat surface, install thermal pad number 184616-002 before installing the heatsink.



CAUTION: Using the wrong thermal pad may cause the processor to overheat or short, resulting in failure.

4. Install the heatsink and the heatsink retaining clip.

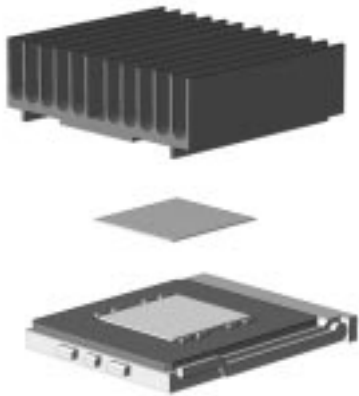


Figure 5-76. *Installing the Thermal Pad*

5. Replace the access panel.
6. Run the Computer Setup utility. Refer to Chapter 7, "Compaq Utilities."
7. Test the system (optional) using the Computer Checkup (TEST) utility. Refer to Chapter 2, "Troubleshooting."

5.2.13.3 Cache Memory

To install an optional cache module onto a Pentium-based system board, complete the following steps:

1. Perform preparation procedures described in Section 5.2.3.
2. Remove the access panel (Section 5.2.6.1).
3. Remove the riser brace (Section 5.2.7).
4. Install the cache module into the cache connector on the system board.

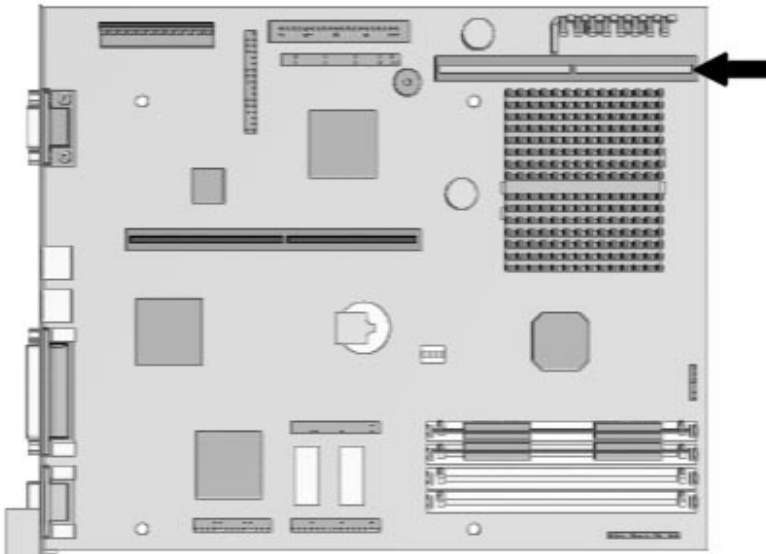


Figure 5-77. Locating the Cache Connector on the System Board

5. Replace the riser brace.
6. Replace the access panel.
7. Reconnect all the cables and turn on the computer. The computer reconfigures the additional memory. Refer to Chapter 7, "Compaq Utilities."

5.2.13.4 PCI Performance Graphics Controller Memory Module Upgrade

To install a graphics memory module upgrade for the Cirrus Logic Performance graphics controller that is preinstalled in the system board, complete the following steps:

1. Perform preparation procedures described in Section 5.2.3.
2. Remove the access panel (Section 5.2.6.1).
3. Remove the riser brace (Section 5.2.7).
4. Install the graphics upgrade module onto the system board.

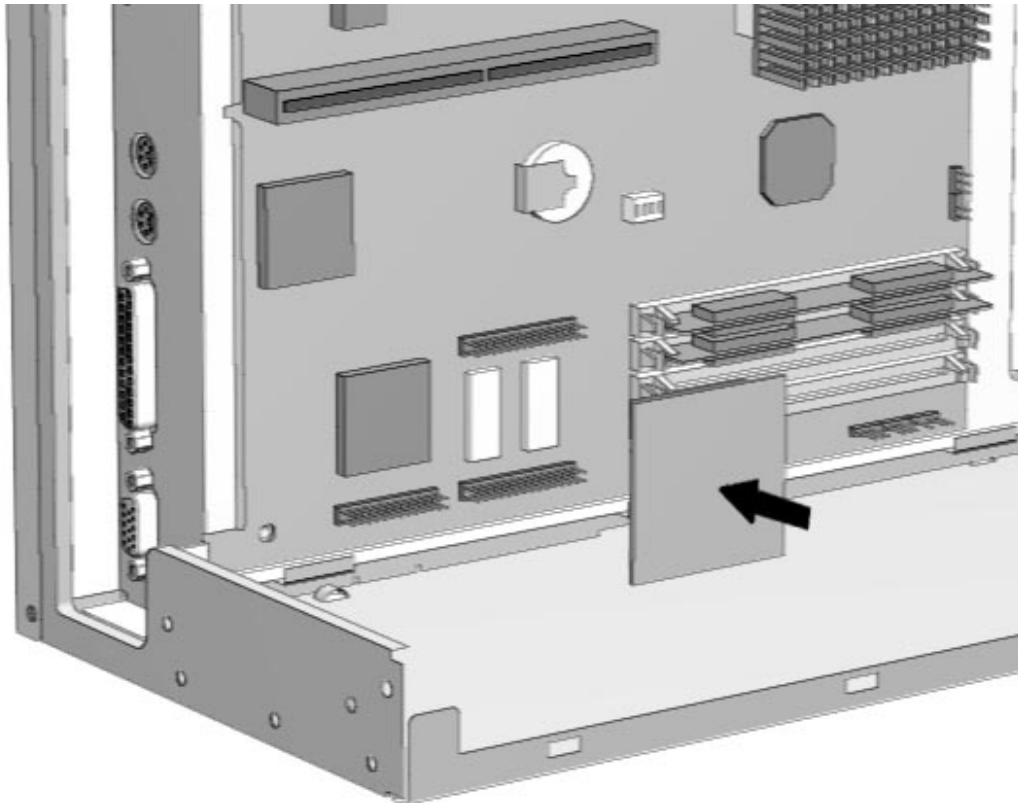



Figure 5-78. Installing a 1-MB EDO DRAM Module onto the System Board

5. Replace the riser board.
6. Replace the access panel.
7. Turn the computer on and start the Windows program.
8. Select the Display icon in the Compaq Utilities group box in Windows NT 3.51 or Windows 3.1, or the Display icon in Windows 95, to take advantage of the additional display modes now available with the upgraded memory. Follow the instructions on the screen.
9. Test the system (optional) using the Computer Checkup (TEST) utility. Refer to Chapter 2, "Troubleshooting."

5. 2.14 System Board

To remove the system board, complete the following steps:

1. Perform preparation procedures described in Section 5.2.3.
2. Remove the access panel (Section 5.2.6.1).
3. Remove the riser brace (Section 5.12).
-  If a replacement external battery is installed on the system board, do not unplug the battery from the system board connector. Unplugging the external battery erases CMOS. Remove the external battery from the hook-and-loop fastener on the drive cage and leave it attached to the system board (Section 5.10).
4. Disconnect any cables plugged into the system board.

5. Slide the system board tray out of the computer.

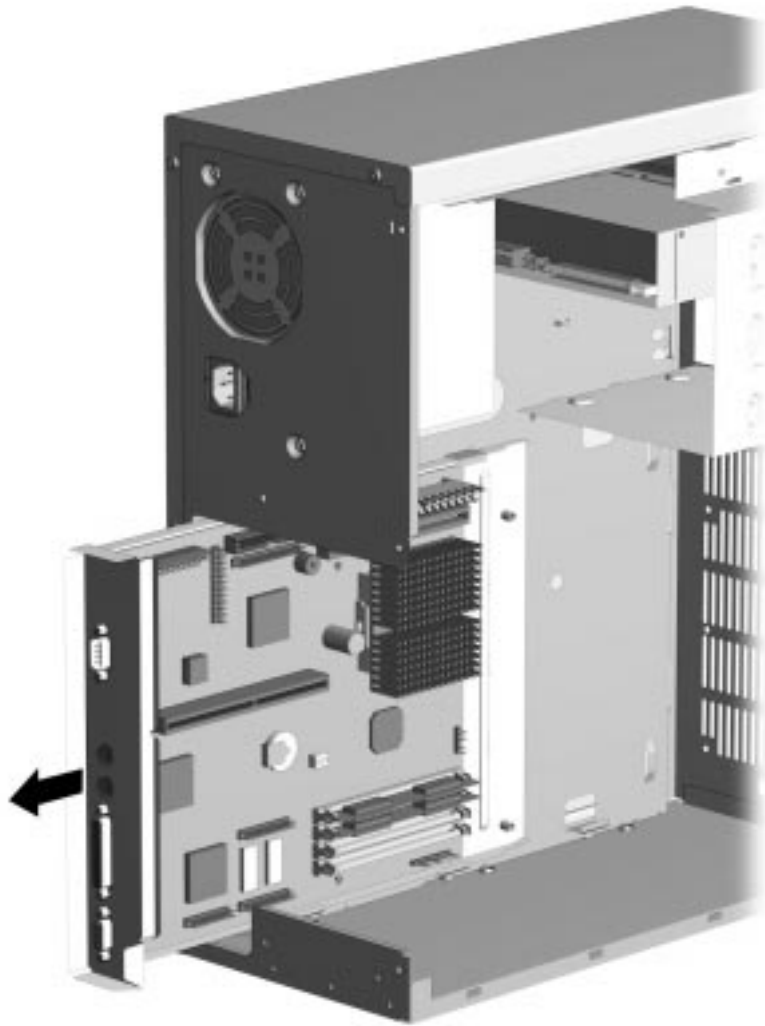


Figure 5-79. Removing the System Board (Minitowers)

To install a new system board, reverse the above procedures.

5.2.15 Speaker

To remove the speaker from the PC complete the following steps:

1. Perform the preparation procedures described in Section 5.2.3.
2. Remove the access panel (Section 5.2.6.1).
3. Remove the riser brace (Section 5.2.7).
4. Disconnect the speaker wire from the Business Pro Audio board or the system board.
5. Remove the speaker-retaining screw.
6. Remove the speaker from the riser brace.

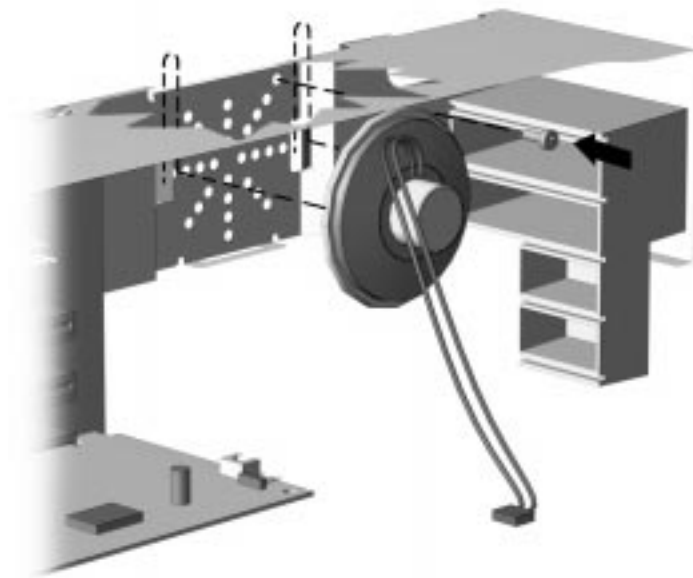


Figure 5-80. *Removing the Speaker*

To install the speaker, reverse the above procedure.

5.2.16 ISA Option Board Retainer

To remove the ISA option board retainer complete the following steps:

1. Perform the preparation procedures described in Section 5.2.3.
2. Remove the access panel (Section 5.2.6.1).
3. With the computer lying on its side, press down on the end of the retainer. The retainer is then easily removed

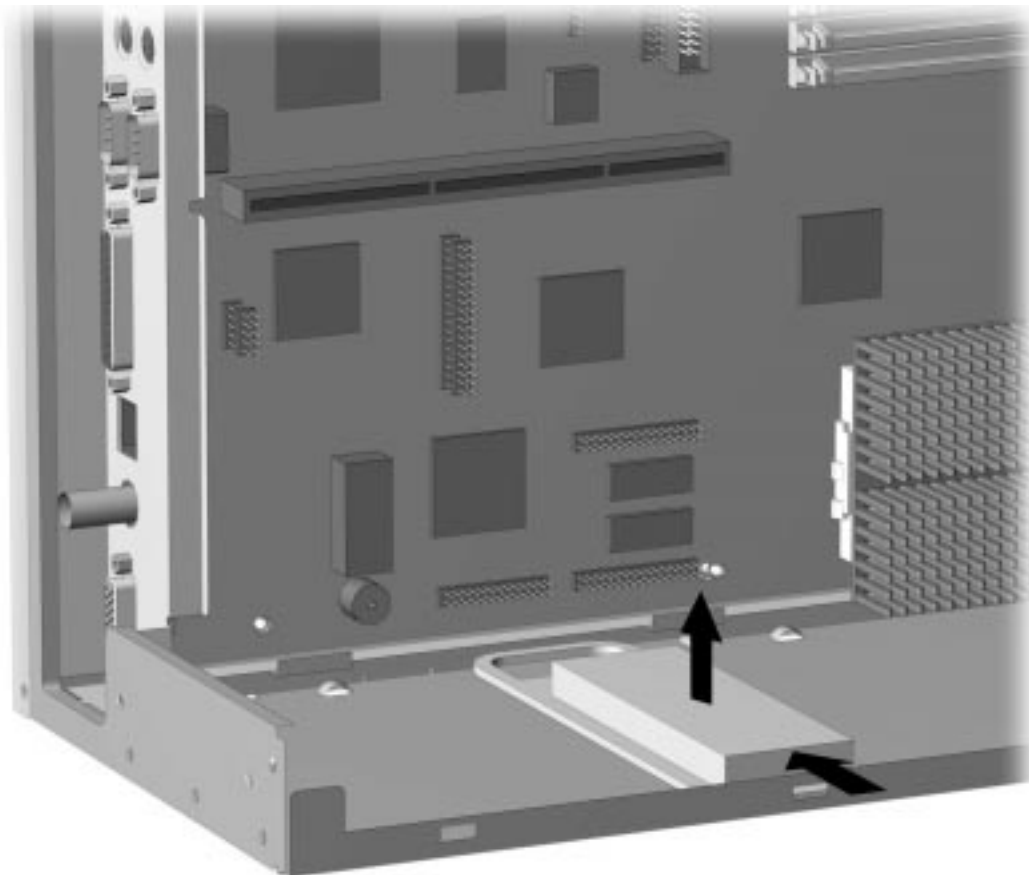


Figure 5-81. Removing the ISA Option Board Retainer

To replace the retainer, reverse the above procedure.

5.2.17 Front Bezel Assembly

When removing or installing the power supply or any mass storage device, you must first remove the front bezel.

5.2.17.1 Front Bezel

The front bezel is mounted to the computer cover with release latches that are integrated into the bezel. To remove the front bezel, complete the following steps.

1. Perform the preparation procedures described in Section 5.2.3.
2. Remove the access panel as described in Section 5.2.6.1.
3. From inside the chassis, push the release latches ❶ in and push the side of the bezel out and away from the chassis ❷ to release the bezel at those points.
4. Rotate the bezel out from the chassis, then slide it to the left.
5. Separate the bezel from the chassis.

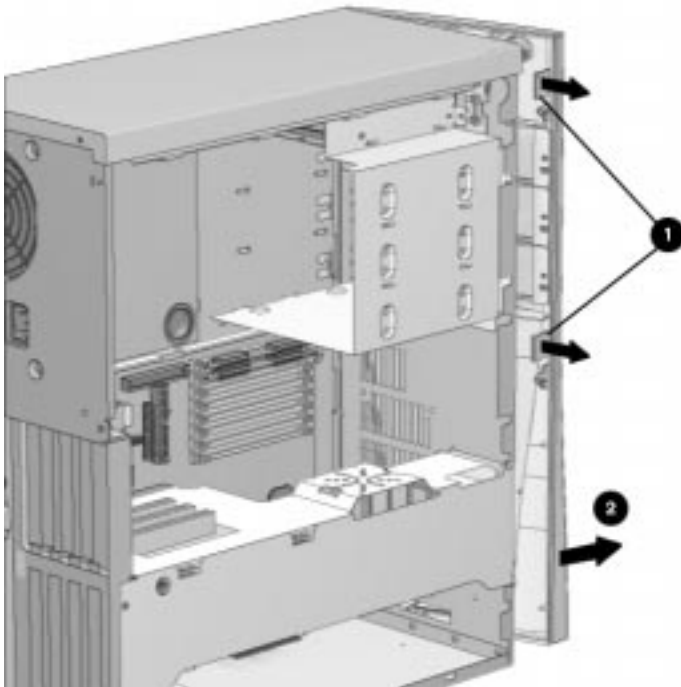


Figure 5-82. Removing the Front Bezel

To replace the front bezel, reverse the above steps, taking care to properly position the hinge points and the release latches before pushing the bezel back into the chassis.

5.2.17.2 Power Button

To remove the power button, complete the following steps:

1. Perform the preparation procedures described in Section 5.2.3.
2. Remove the access panel as described in Section 5.2.6.1.
3. Remove the front bezel as described in Section 5.2.17.1.
4. Hold the front access panel in one hand with the inside surface towards you.
5. Pinch the two tabs of the power button together and slip the button out of the front of the bezel. The spring will follow the button out of the housing.

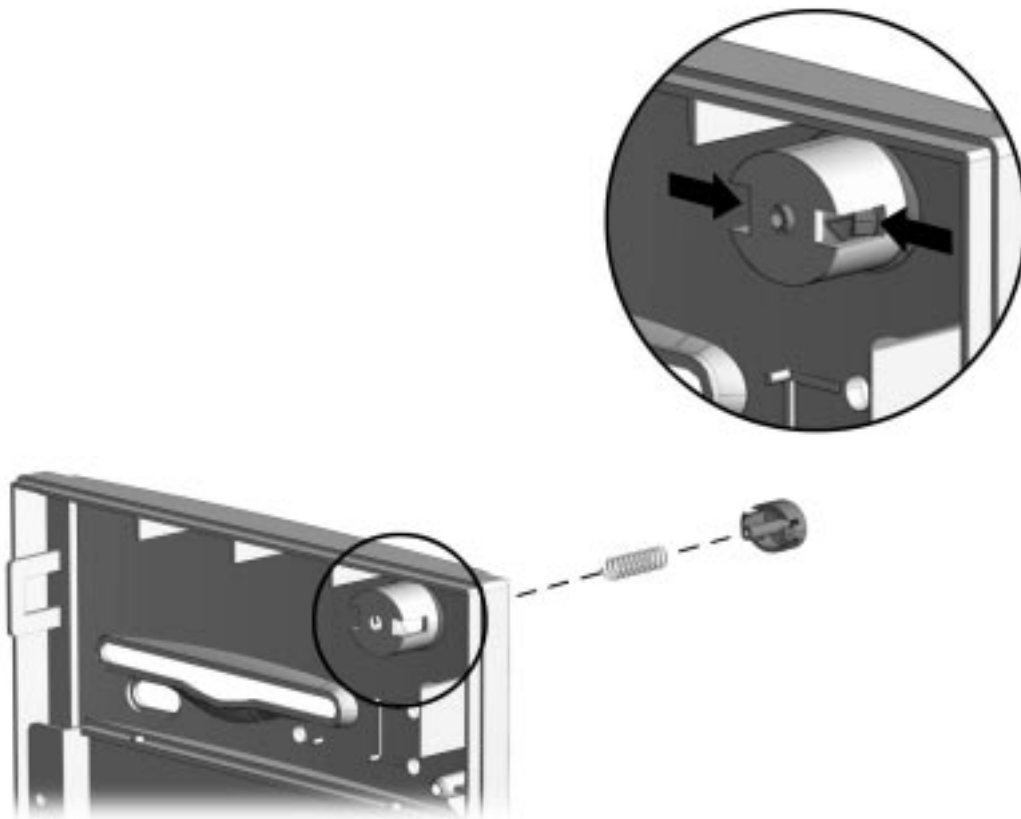


Figure 5-83. Removing the Power Button

To replace the power button, reverse the above steps.

5.2.17.3 Bezel Blank

To remove the bezel blank, complete the following steps:

1. Perform the preparation procedures described in Section 5.2.3.
2. Remove the access panel as described in Section 5.2.6.1.
3. Remove the front bezel as described in Section 5.2.17.1.
4. Lay the front bezel face down on a protected work surface and remove the two screws that secure the bezel blank to the bezel.
5. Remove the bezel blank from the front bezel.

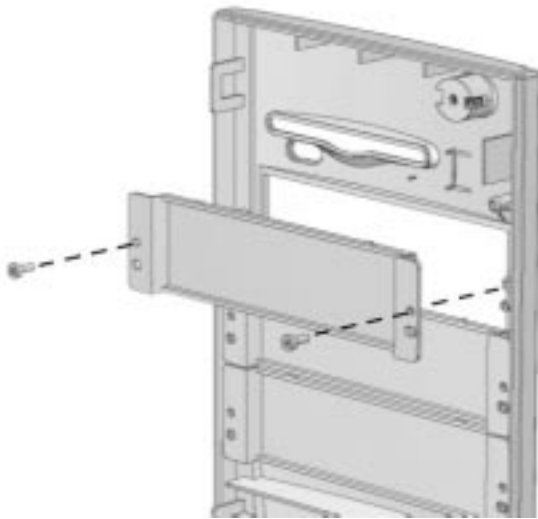


Figure 5-84. Removing the Bezel Blank

To replace the bezel blank, reverse the above procedures.

5.2.18 Compaq Logo

The Compaq logo is secured to the front bezel with adhesive. To replace the logo, complete the following steps:

1. Remove the access panel as described in Section 5.2.3.
2. Remove the front bezel as described in Section 5.2.17.1.
3. From the inside of the front bezel, use a small screwdriver at the hole shown in the figure to push the logo out of the front bezel.
4. Use a clean cloth to clean the recessed area in the front bezel where the logo is to be installed.
5. Remove the protective cover from the back of the replacement logo and press it into place.

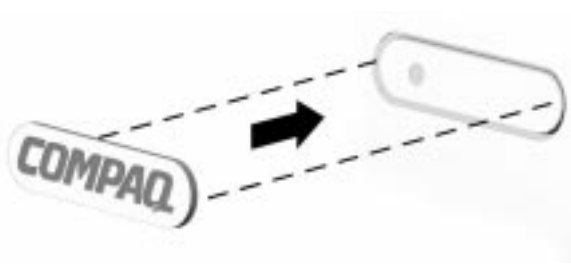


Figure 5-85. *Installing the Compaq Logo on a Minitower*

If the original logo is missing, complete steps four and five to replace the logo without removing the unit cover assembly.

5.2.19 Power Supply

To remove the power supply and power supply switch, complete the following steps:

1. Perform preparation procedures described in Section 5.2.3.
2. Remove the access panel (Section 5.2.6.1).
3. Remove the front bezel (Section 5.2.17.1).
4. From outside the chassis, remove the screw that attaches the power switch and its bracket to the front of the chassis.
5. From inside the chassis, pull the power switch and its bracket free from the chassis.
6. Remove the power supply switch.

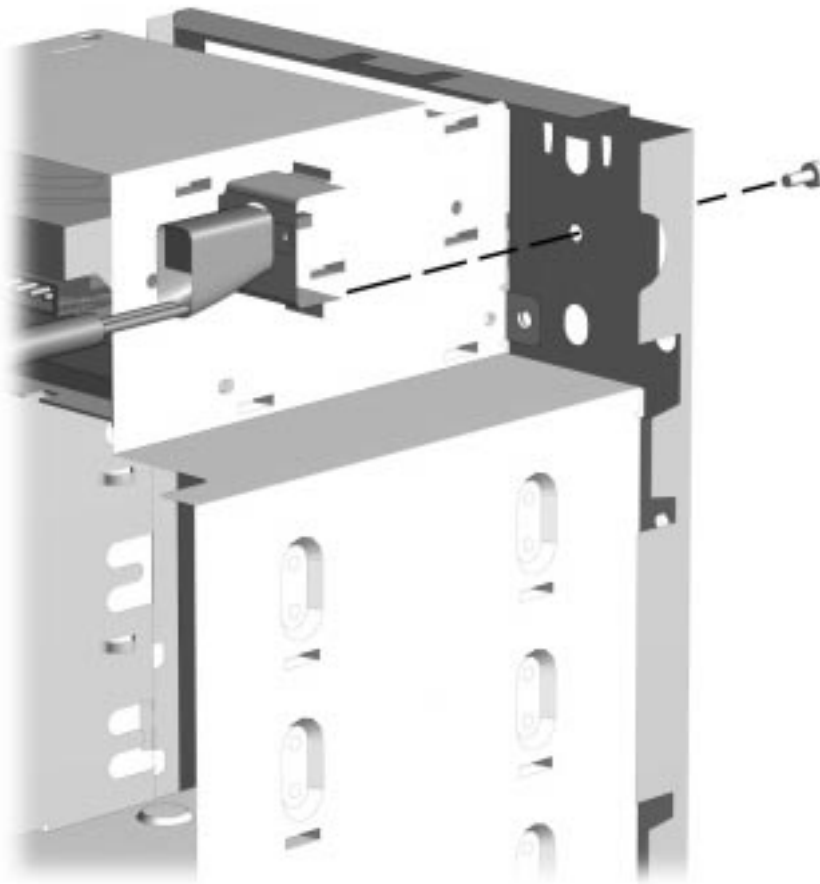


Figure 5-86. Removing the Power Supply Switch and Bracket

7. Disconnect all power cables from the mass storage devices at the system board.

✎ To facilitate reassembly, note the orientation of each cable connector and the routing of each cable before you remove it.

8. From inside the chassis, remove the two screws at the front of the power supply that attach it to the chassis.

9. Remove the three screws that secure the power supply to the back of the chassis

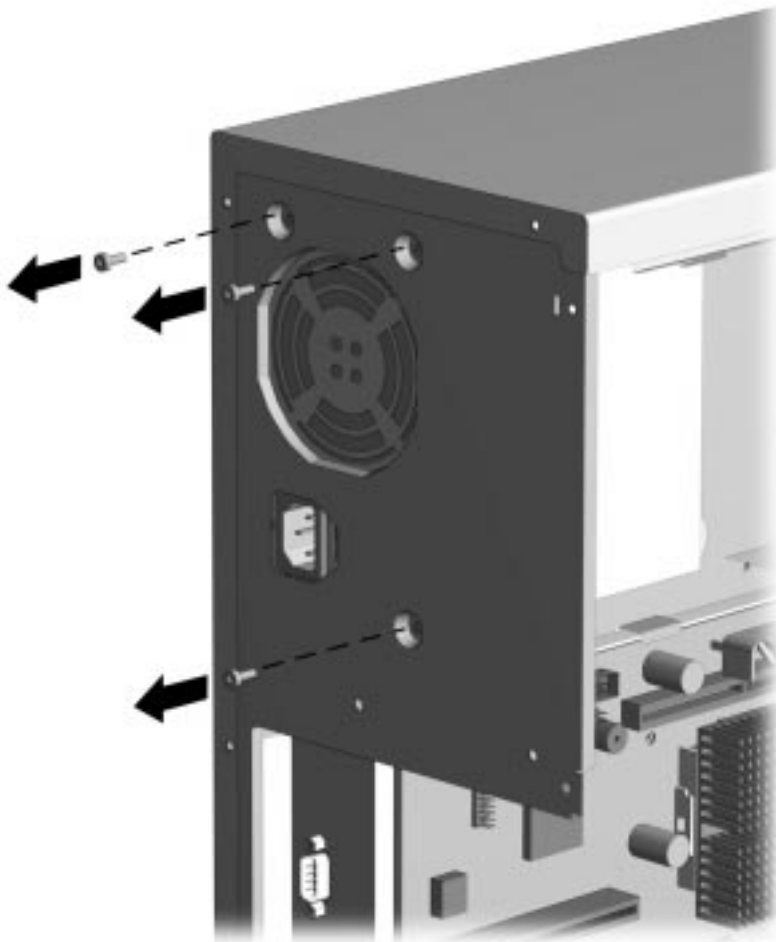


Figure 5-87. Removing the Screws from the Chassis

10. Remove the two screws inside the chassis that secure the power supply.
11. Pull the power supply out of the chassis.

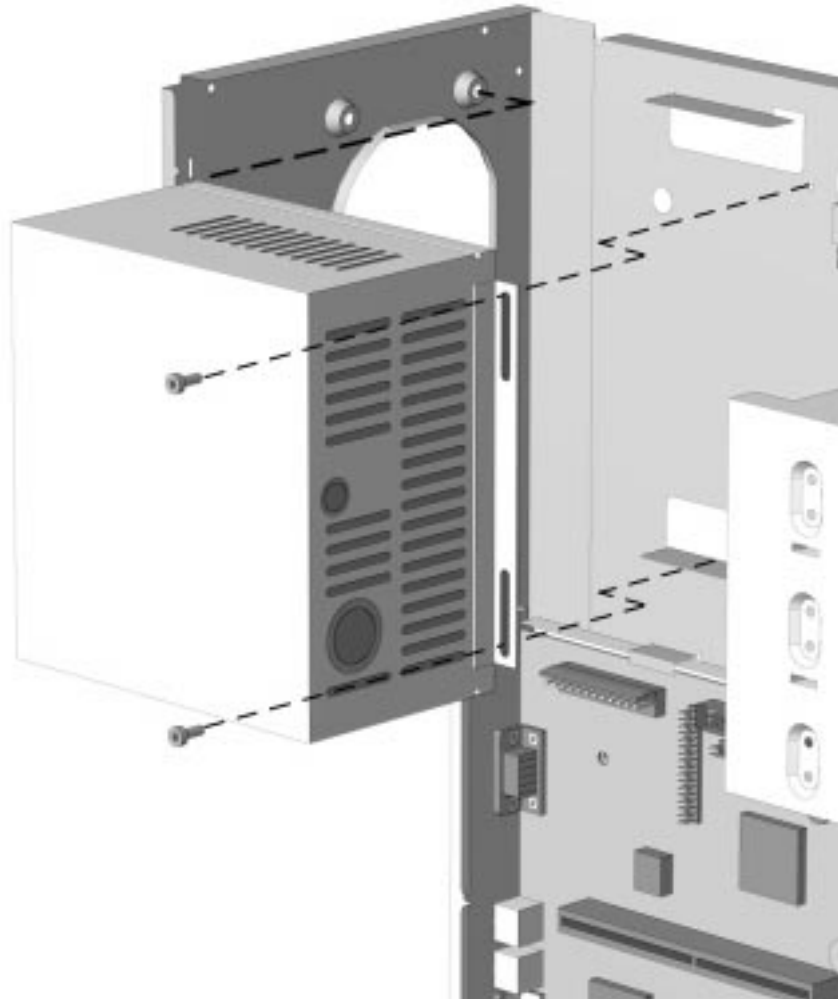


Figure 5-88. Removing the Power Supply

- ✎ The power supply is used for both the desktop and minitower personal computers and is spared with the switch mounting bracket. Install the bracket in the same orientation on the power supply and switch assembly being replaced. The bracket is held in place with two T-10 screws.

To replace the power supply assembly, reverse the above procedure.

5.2.20 Mass Storage Devices

This section discusses the removal and replacement procedures for the mass storage devices that are supported on the Compaq Deskpro 2000 Series of Personal Computers.

Drive Positions

The minitower drive bays and their functions are:

- ❶ One 3.5-inch internal bay for hard drive
- ❷ Standard 3.5-inch, external third-height diskette drive
- ❸ Standard 5.25-inch external drive for CD-ROM drive, optional tape drive, hard drive, or diskette drive (one-half height)
- ❹ Optional 5.25-inch external drive for CD-ROM drive, tape drive, hard drive, or diskette drive (one-third height)
- ❺ One 5.25-inch external bay for hard drive

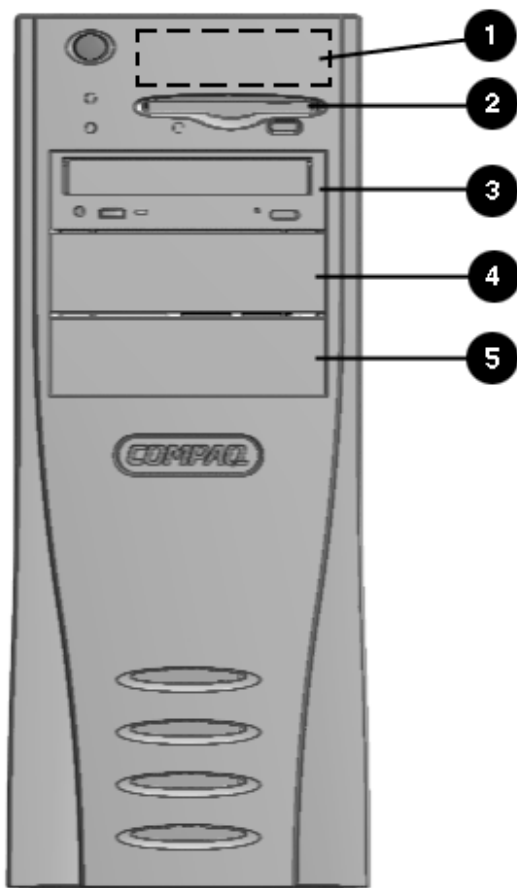


Figure 5-89. Five Drive Bay Positions on the Minitower Computer

- ✎ The computer will have either a 5.25-inch hard drive installed in location ❺ or a 3.5-inch hard drive installed in location ❶.

Adding an Additional Drive

For information on installing an additional hard drive or CD-ROM drive using cable-select technology, refer to Appendix C, “Hard Drives” and to Section 5.2.20.3.

5.2.20.1 3.5-Inch Wide Drive Bays

The computer has two 3.5-inch third-height drive bays, one of which is occupied by the diskette drive.

To remove a 3.5-inch drive from the 3.5-inch wide drive bay, complete the following steps:

1. Perform preparation procedures described in Section 5.2.3.
2. Remove the access panel (Section 5.2.6.1).
3. Remove the front bezel (Section 5.2.17.1.)

4. Disconnect the interconnect cables from the back of the drive.

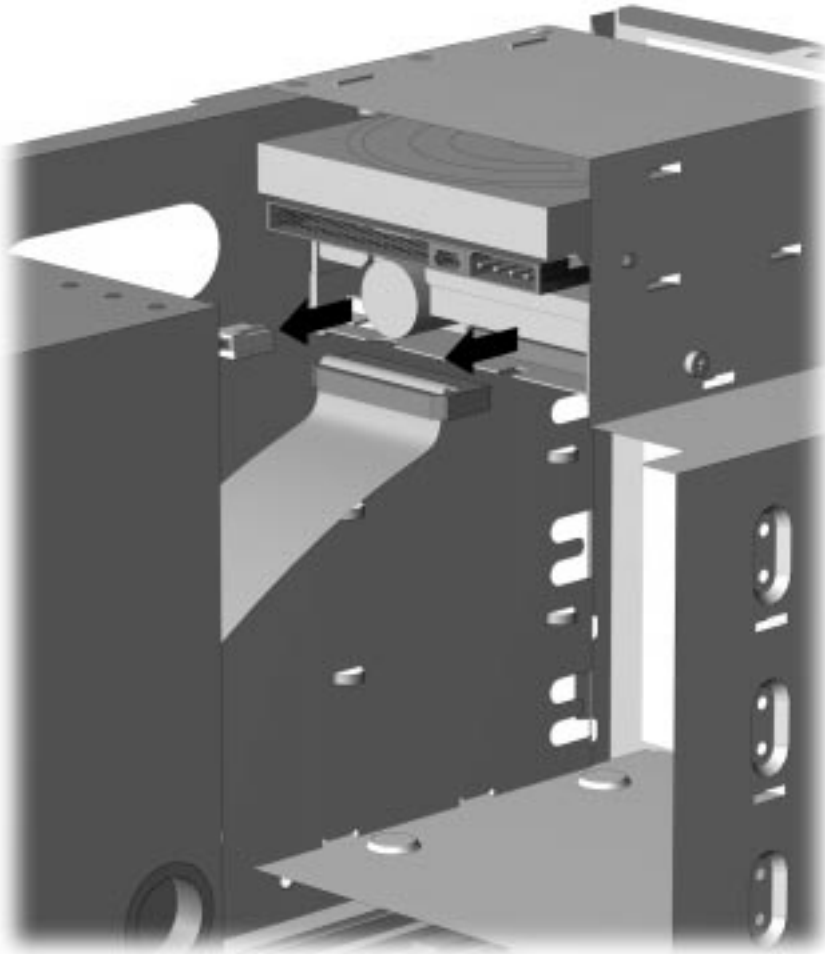


Figure 5-90. Disconnecting the Interconnect Cables from the 3.5-Inch Diskette Drive

5. Remove the two high hat screws on the left of the drive that secures the drive in the chassis.
6. Pull the 3.5-inch drive straight out of the chassis.

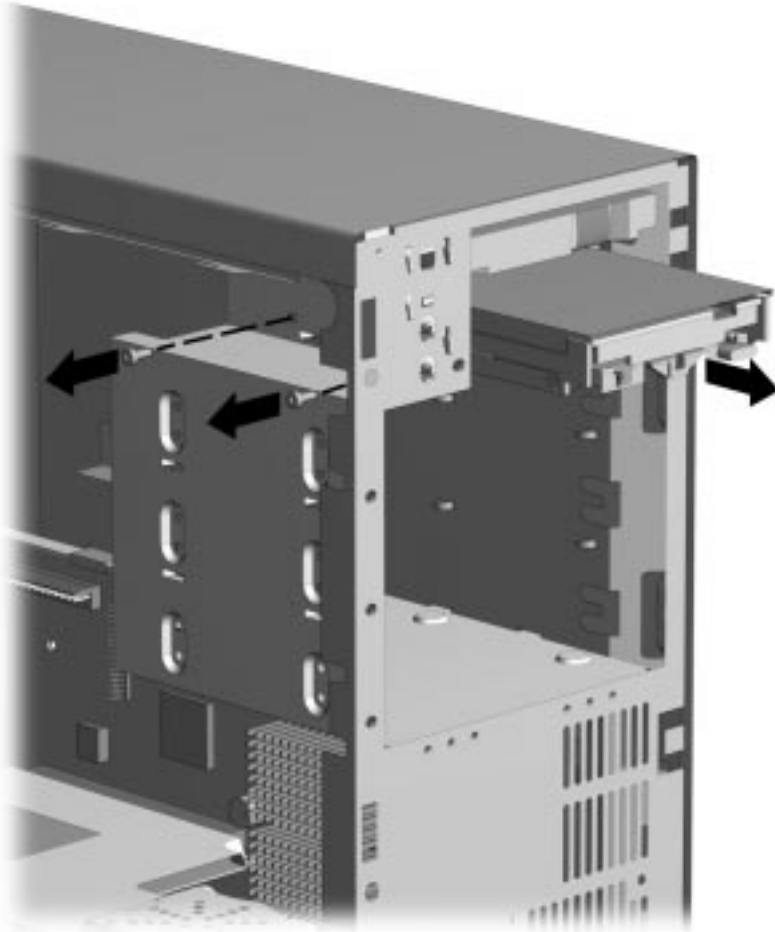


Figure 5-91. Removing the 3.5-Inch Diskette Drive

When replacing this drive, transfer the high hat screw from the old drive to the new one. The screw is installed on the right side in the middle.

✎ The high hat screw on the right side is a guide screw that takes the place of drive rails.

To replace the 3.5-inch drive, reverse the above procedure.

Always ensure that the cables are placed in their proper locations during the reassembly process.



CAUTION: When servicing this computer, ensure that cables are placed in their proper locations during the reassembly process. Improper cable placement can damage the computer.



CAUTION: Use only 3/16-inch or 5-mm long screws as guide screws. Longer screws can damage the internal components of the drive.

5.2.20.2 5.25-Inch Wide Drive Bays

The 5.25-inch wide drive bays may be occupied by hard drives, CD-ROM, PD-CD, or tape drives.

Before beginning the removal procedure, ensure that all removable media have been removed from the drive.



CAUTION: Before beginning this procedure, turn off the power to the computer.

If you need to manually eject a CD from the CD-ROM drive, insert a metal rod that is approximately 1.2 mm in diameter and at least 35 mm in length (1/16 x 1 3/8 inches) into the manual eject hole and push firmly. A straightened paper clip works well. The tray will come out 1/4 to 1/2 inch. Pull the tray out by hand until the CD can be removed.

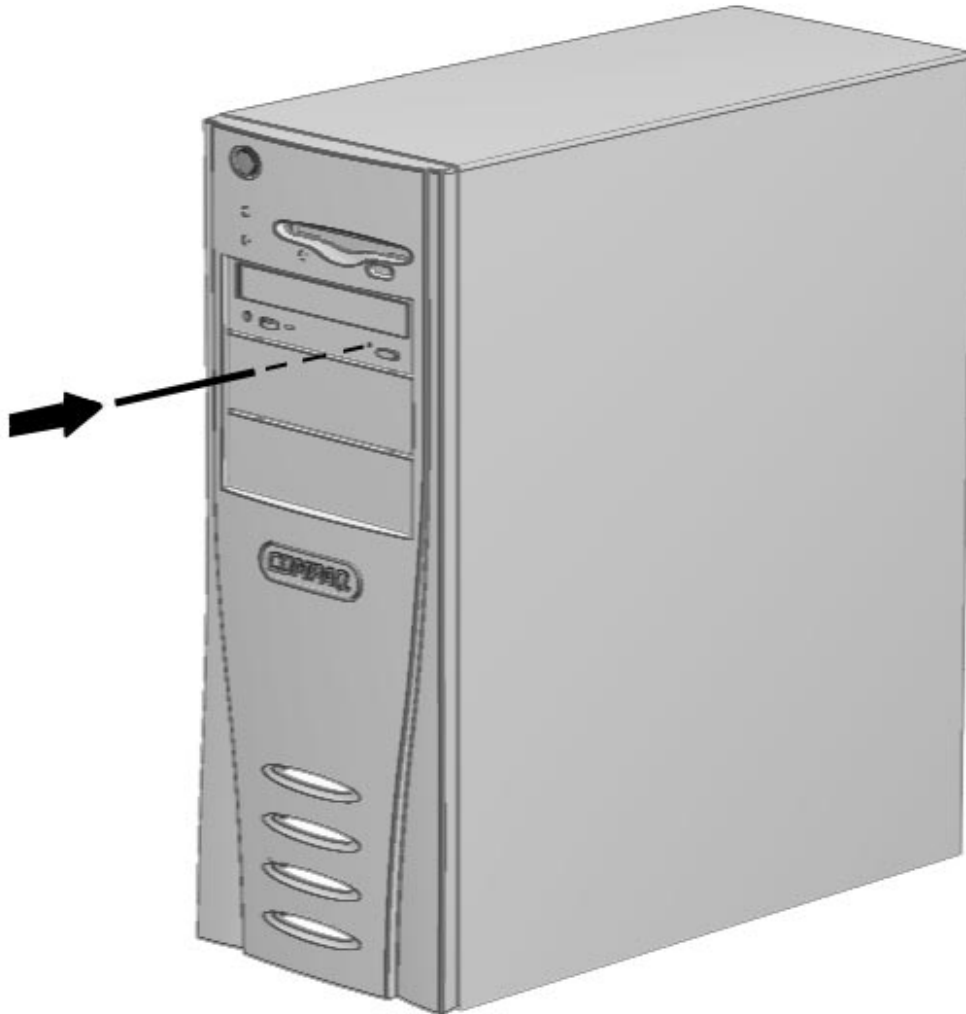


Figure 5-92. Manually Ejecting a Compact Disc

To remove a drive from a 5.25-inch wide bay, complete the following steps:

1. Perform preparation procedures described in Section 5.2.3.
2. Remove the access panel (Section 5.2.6.1).
3. Remove the front bezel (Section 5.2.17.1).
4. Disconnect all cables from the back of the drive.

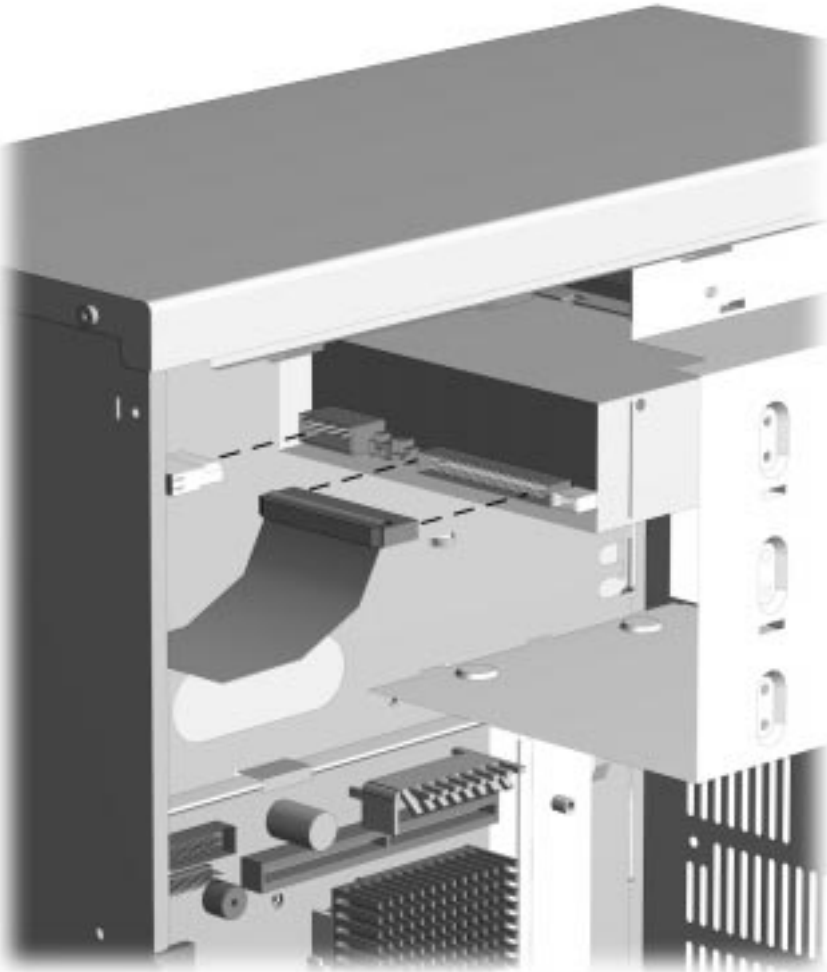


Figure 5-93. Disconnecting the Signal and Power Cables from the CD-ROM Drive (Desktop)

5. Remove the two screws on the left side of the drive that secure the drive in the chassis.
6. Pull the drive straight out of the chassis.

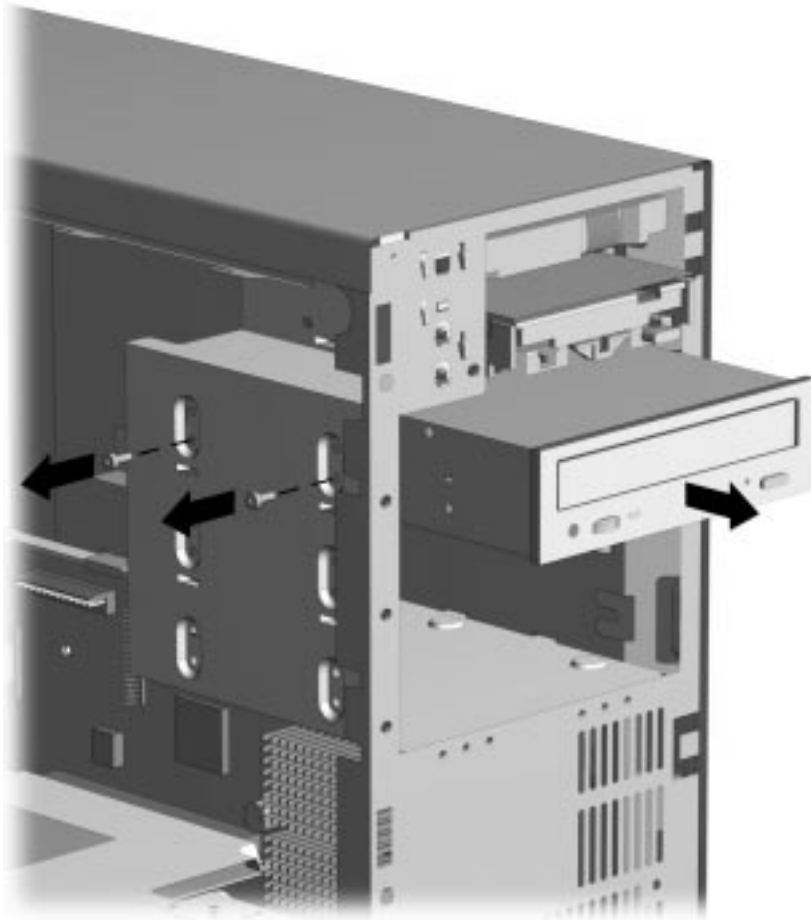


Figure 5-94. Removing the CD-ROM Drive

To replace the 5.25-inch wide drive bay device, complete the following steps:

1. Transfer the high hat screw from the old drive to the new one. The screw is installed on the right side of the drive, in the middle.
2. Reverse the above procedures.

5.2.20.3 Installing a New Drive

When installing a new drive into the computer you should use either the high hat screw provided with the option kit or the extra U.S. and metric screws stored in the front of the computer frame for this purpose. Select the appropriate screws for the application.

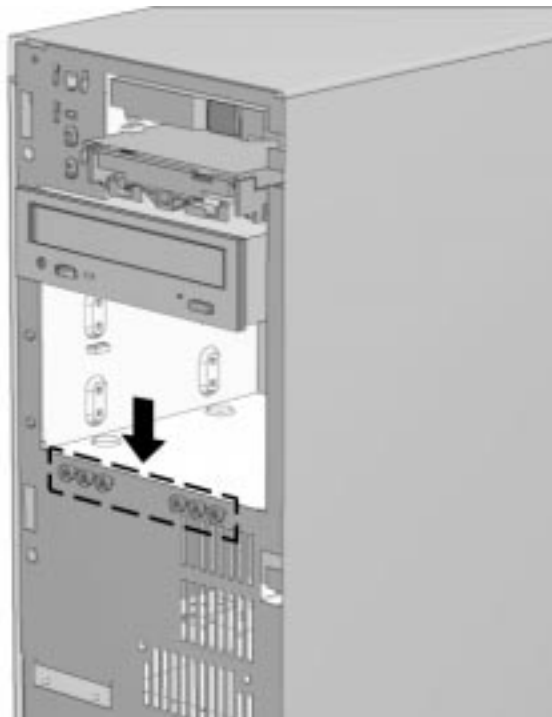


Figure 5-95. Locating the Flanged Screws

✎ Metric screws have a black finish while U.S. screws have a silver finish.

1. If you are installing a 3.5-inch drive into a 3.5-inch wide drive bay or a 5.25-inch drive into a 5.25-inch wide drive bay, continue with step 2.

If you are installing a 3.5-inch drive into a 5.25-inch wide drive bay, skip to step 5.

2. Install one high hat screw on the right side of the front of the hard drive.



Figure 5-96. *Installing the Flanged Screws into the Hard Drive*

3. Install the hard drive assembly into the drive bay and secure the drive with two retaining screws on the left side of the chassis.

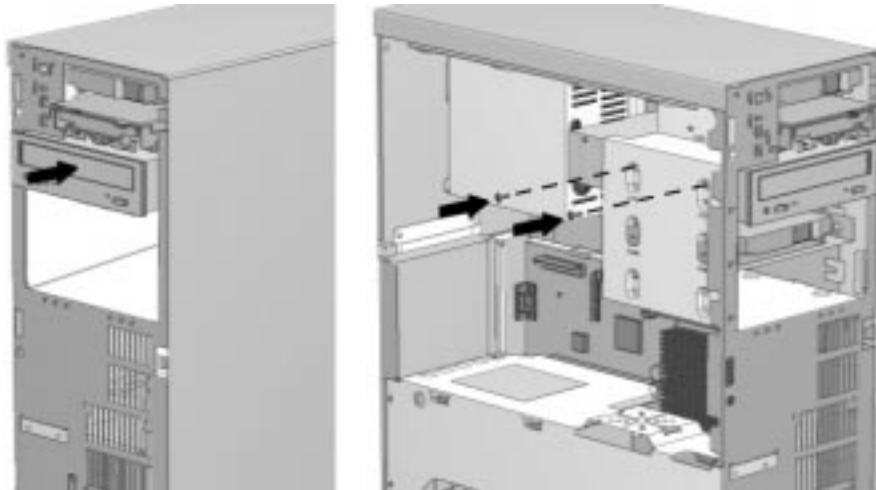


Figure 5-97. *Installing the Hard Drive, Drive Bezel, and Retaining Screw*



CAUTION: Use only 3/16-inch or 5-mm long screws as guide screws. Longer screws can damage the internal components of the drive.

4. Continue with Step 9.

5. If you are installing a 3.5-inch diskette drive, use bracket number 243230-001 which comes with a preinstalled bezel. This bracket is available from your Compaq dealer or service provider.

If you are installing a 3.5-inch hard drive, use bracket number 243231. This bracket is available from your Compaq dealer or service provider.

6. Place the 3.5-inch drive into the bracket.

7. Insert two screws into the bracket holes on each side of the bracket to secure the drive.

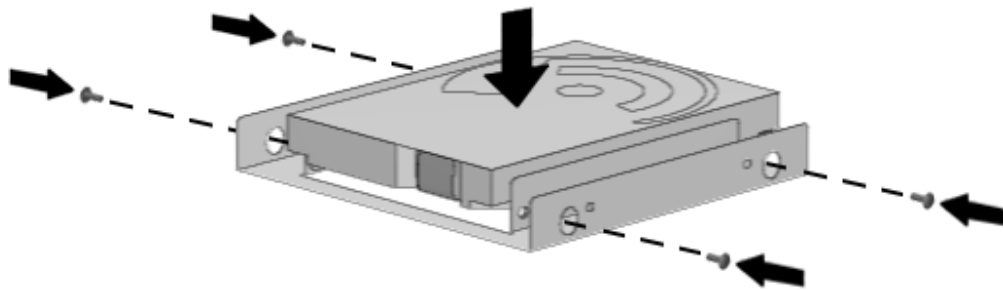


Figure 5-98. *Placing the Hard Drive and Inserting Four Screws into the Bracket*

8. Install one high hat screw from step 1. Insert the screw on the right side of the bracket. This screw is used to align the bracket in the drive bay.



Figure 5-99. *Inserting the High Hat Screw into the Bracket*

9. Install the drive assembly into the drive bay positioning the guide screw into the tabs on the side of the drive bay.
10. Secure the hard drive with the screws packed in the option kit.

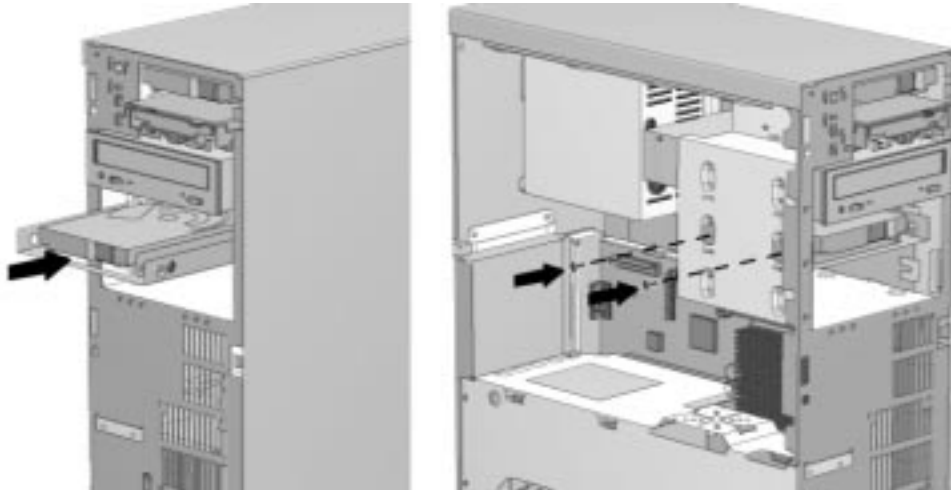


Figure 5-100. *Installing the Hard Drive and Securing it with Two Retaining Screws*



CAUTION: Use only 3/16-inch or 5-mm long screws as guide screws. Longer screws can damage the internal components of the drive.

11. Connect the drive cables.

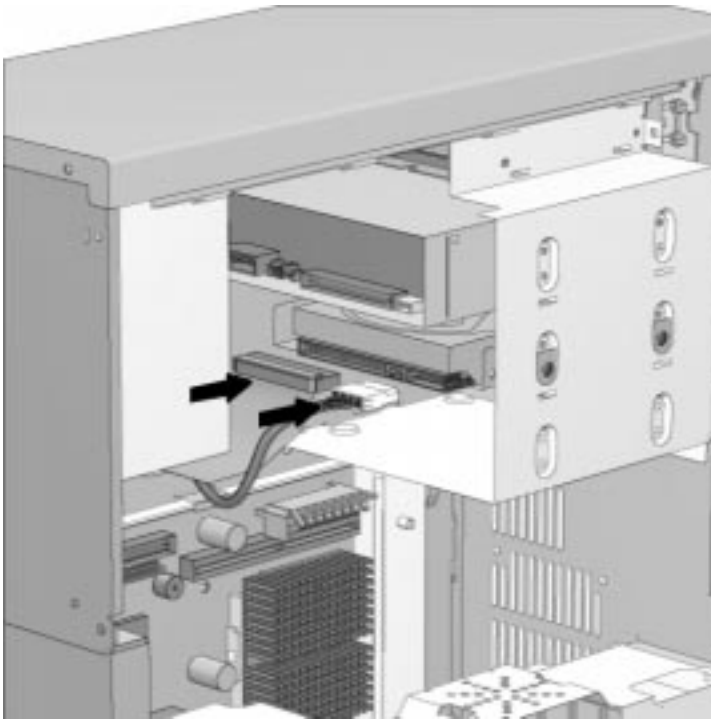


Figure 5-101. Connecting the Cables



CAUTION: When servicing this computer, ensure that cables are placed in their proper locations during the reassembly process. Improper cable placement can damage the computer.

12. Remove the bezel blank from the front bezel (Section 5.2.17.3).
13. Install the front bezel.
14. Install the access panel.
15. The system will automatically recognize a hard drive sold by Compaq and will automatically reconfigure the computer. If you have installed a third party hard drive, you will need to run Computer Setup to reconfigure the computer. Refer to Chapter 7, " Compaq Utilities," for information on running Computer Setup.
16. Test the system (optional) using the Computer Checkup (TEST) utility. Refer to Chapter 2, "Troubleshooting."

The figure below illustrates the recommended ribbon cable position for the CD-ROM drive.

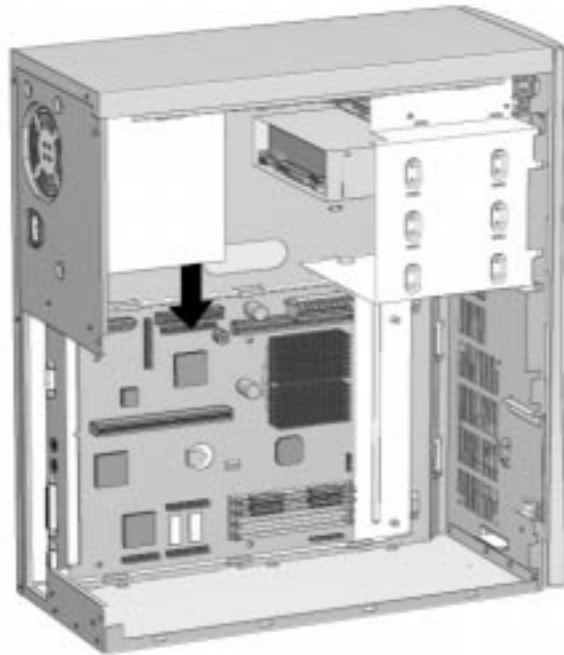


Figure 5-102. Ribbon Cable Position for the CD-ROM Drive

5.2.21 LED Cable

To remove the LED cable, complete the following steps:

1. Perform the preparation procedures described in Section 5.2.3.
2. Remove the access panel (Section 5.2.6.1).
3. Remove the riser brace (Section 5.2.7).
4. Disconnect the cable from the connection on the system board.
5. Remove the LED end of the cable from the front of the chassis by gently pulling on the cable while at the same time pushing the end of the LED from the front of the chassis.

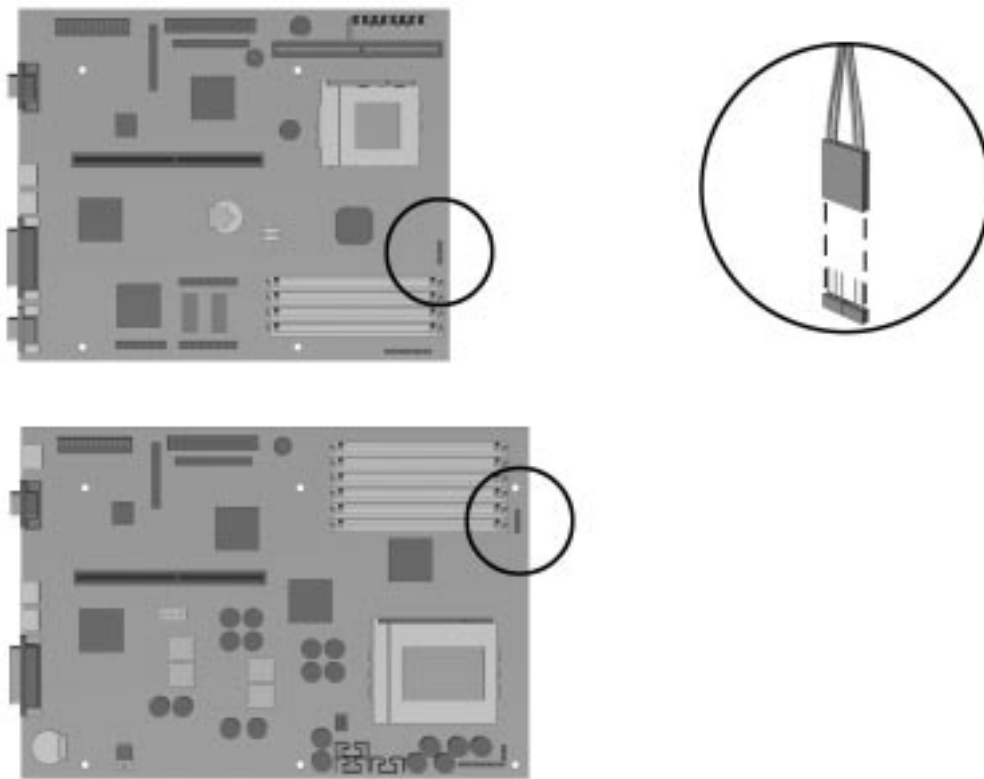


Figure 5-103. Removing the LED Cable From the Pentium (Top) and Pentium Pro (Bottom) System Boards

✎ The connector is keyed to ensure proper installation.

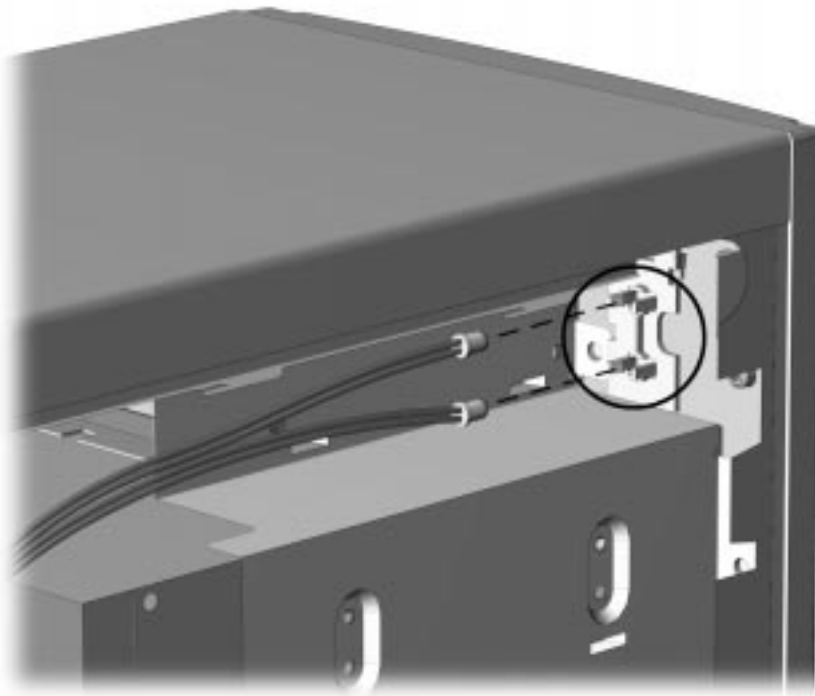


Figure 5-104. *Removing the LED Cable From the Front of the Chassis*

To install the LED cable, reverse the above steps.

chapter 6

JUMPER AND SWITCH INFORMATION

This chapter provides jumper and switch information for system board jumpers, system I/O board connectors, and hard drives for the Compaq Deskpro 2000 Series of Personal Computers.

6.1 System Board Switches

6.1.1 Pentium-Based System Board

The Pentium-based system board has one switch module (SW1). SW1 ① is used to select processor speed settings for the Pentium microprocessor.

The following illustration shows the switch location.

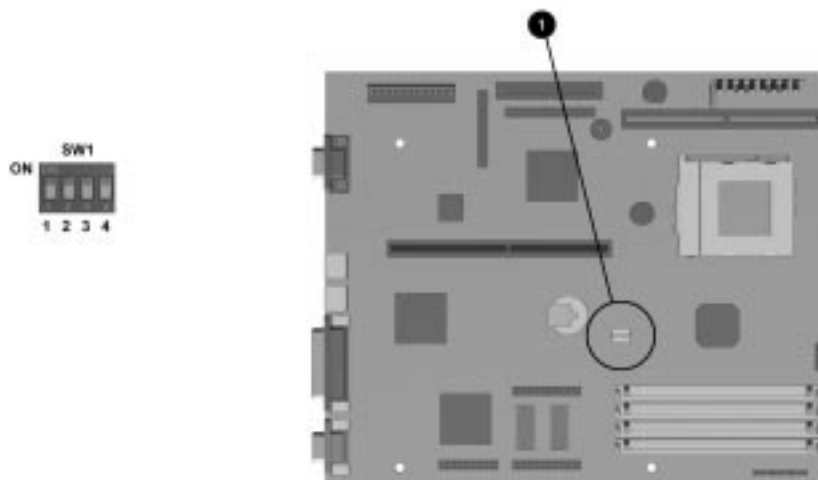


Figure 6-1. Pentium-Based System Board Switch Module Locations

6.1.2 Pentium Pro-Based System Board

The Pentium Pro-based system board has one switch module (SW1). SW1 ① is used to select processor speed settings for the Pentium Pro microprocessor.

The following illustration shows the switch location.

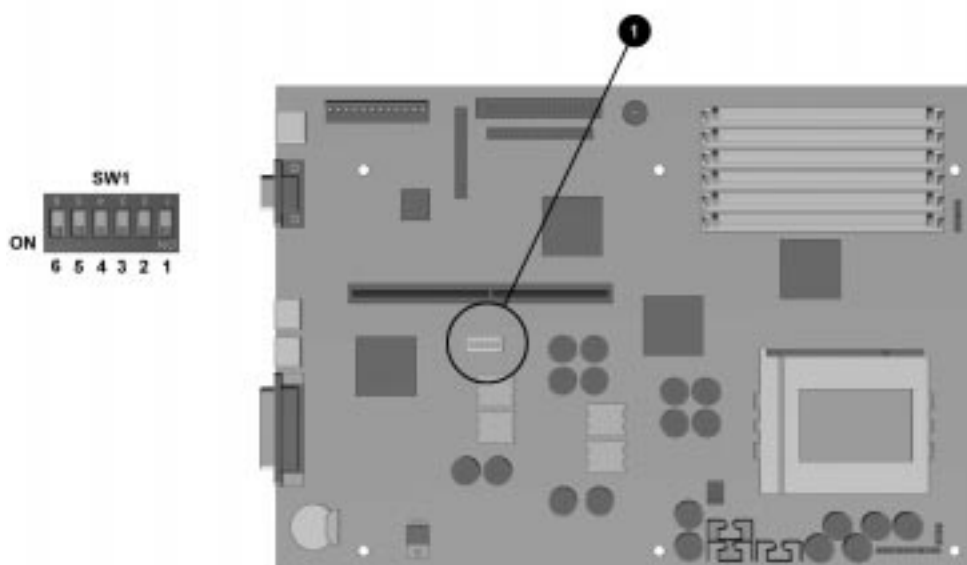


Figure 6-2. Pentium Pro-Based System Board Switch Module Locations

6.1.3 Switch Settings

The following table identifies the switch settings for each processor frequency for the Pentium and Pentium Pro-based system boards.



CAUTION: Do not configure the system board to operate faster than the speed at which the processor is rated. Doing this could result in unreliable operation or processor damage.


Table 6-1
Pentium and Pentium Pro-Based System Board SW1 Settings


S1	S2	S3	S4	S5	S6	Bus/Processor Speed	Processor Type
OFF	ON	OFF	OFF			66/100 MHz	Pentium
ON	OFF	ON	OFF			60/120 MHz	Pentium
OFF	ON	ON	OFF			66/133 MHz	Pentium
OFF	ON	ON	ON			66/166 MHz	Pentium
OFF	ON	OFF	ON			66/200 MHz	Pentium
ON	OFF	ON	ON	OFF	ON	60/180 MHz	Pentium Pro
OFF	ON	ON	ON	OFF	ON	66/200 MHz	Pentium Pro


6.2 System Board Jumpers

This section provides information for setting jumpers for enabling/disabling passwords and clearing the configuration (CMOS). When you change a security feature, you will need to reset a jumper and reconfigure the computer to recognize this change. If the system configuration is incorrect, your computer may not work properly and you may receive error messages on the screen. Setting the system board jumpers are part of the reconfiguration process, along with running the Computer Setup utility.

The jumper settings on the Pentium and Pentium Pro-based system boards are identical.

 To change the system board jumpers, you must remove the computer hood or access panel. For procedures on removing the computer hood or access panel, refer to Chapter 5.

 **WARNING:** To reduce the risk of personal injury from hot surfaces, allow the internal system components to cool before touching.

 **CAUTION:** Be sure to turn off the computer before changing a jumper setting or damage to the system board can result.

6.2.1 Jumper Locations

Pentium-Based System Board

E8	E6	E9
Clear CMOS	5-6=ENA 6-7=DIS	Ext. Batt.

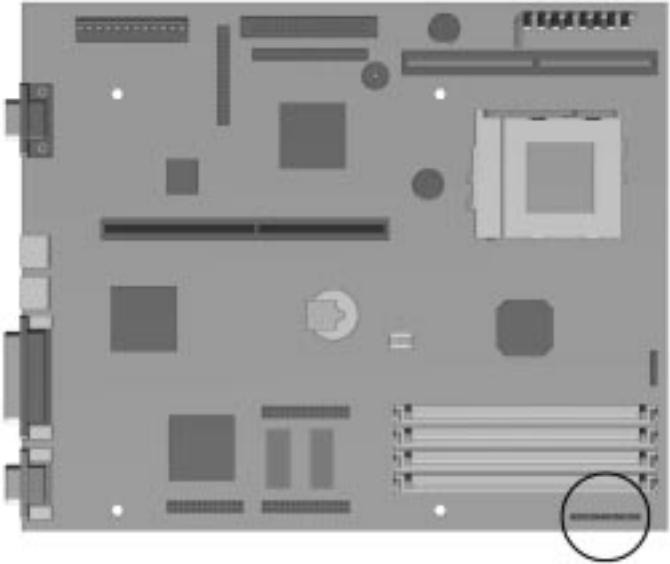


Figure 6-3. Locating Jumpers on the Pentium-Based System Board

Pentium-Pro Based System Board

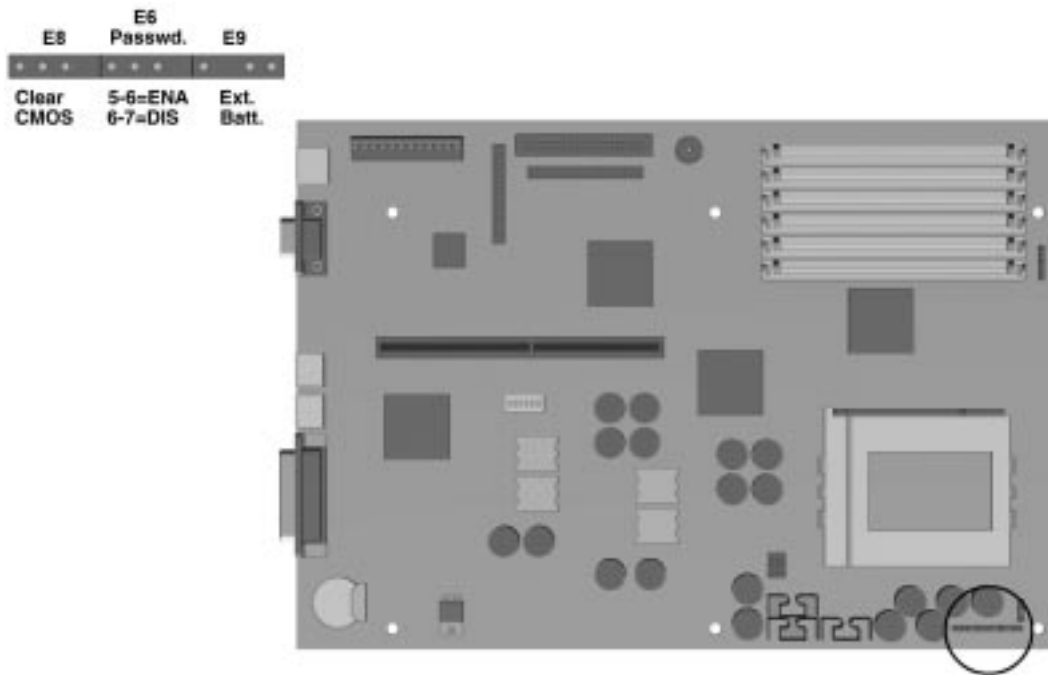


Figure 6-4. Locating Jumpers on the Pentium Pro-Based System Board

6.2.2 Setting Power-On Password Jumpers

The Power-On Password feature is enabled or disabled by moving the plug on the E6 jumper located on the system board. The E6 jumper has three pins. The Power-On Password comes enabled by default with the plugs on pins 5 and 6. To clear or disable the Power-On Password, move the plug to pins 6 and 7.

- ✍ To set a new password, move the E6 jumper back to pins 5 and 6, restart the computer, and reestablish your password through Security Management.

6.2.3 Clearing Configuration

The computer's configuration (CMOS) may occasionally be corrupted. When it does, it is necessary to clear the CMOS memory.

To clear and reset the configuration perform the following procedure:

1. Prepare the computer for disassembly by following the procedures specified in Section 5.3.
2. Remove the hood or access panel (see Section 5.6).
3. Remove the E8 jumper from pins 1 and 2 for 60 seconds; then replace the jumper.
4. Replace the cover and tighten the thumbscrews on the rear panel.
5. Turn the computer on.
6. Run the Computer Setup utility to reconfigure the system.

When jumper E8 is removed, the password becomes invalid because the password is stored in the configuration memory. You will need to reset the password.

6.2.4 Changing the Real-Time Clock (RTC) Battery

When installing the replacement RTC Battery, the battery connector is keyed and should be connected to the pins on the E9 battery header connector.

Refer to Chapter 5 for complete instructions on installing a replacement RTC battery.

6.3 Hard Drives

For more information about Compaq hard drives, refer to Appendix C in this guide.

6.3.1 630-MB IDE Hard Drive Jumper Settings.

The jumper settings for the 630-MB IDE are shown below.

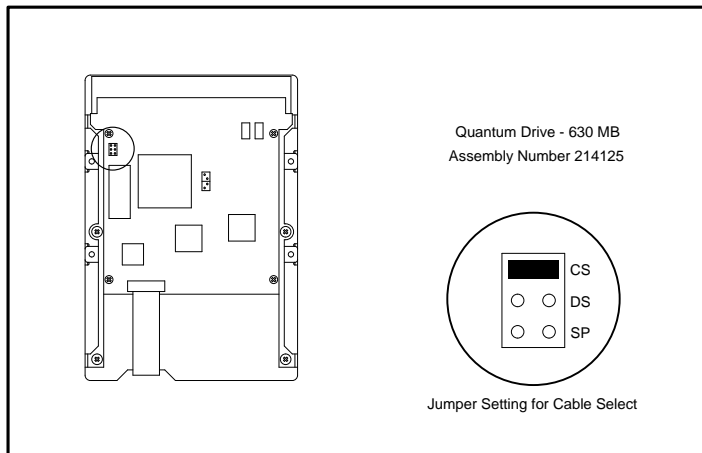


Figure 6-5. 630-MB Quantum IDE Hard Drive Jumper Settings

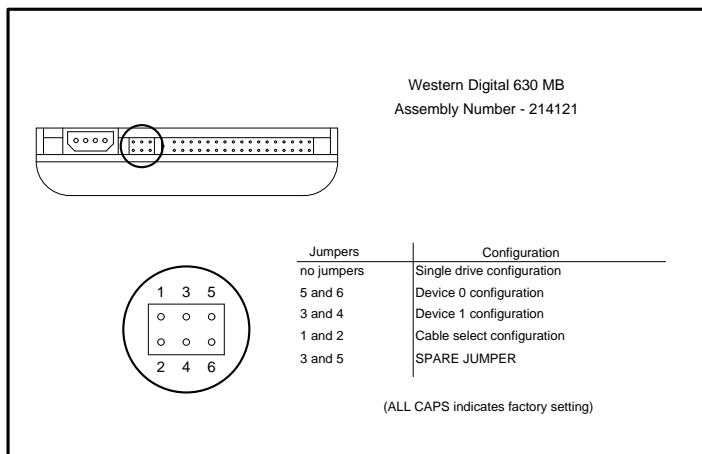


Figure 6-6. 630-MB Western Digital IDE Hard Drive Jumper Settings

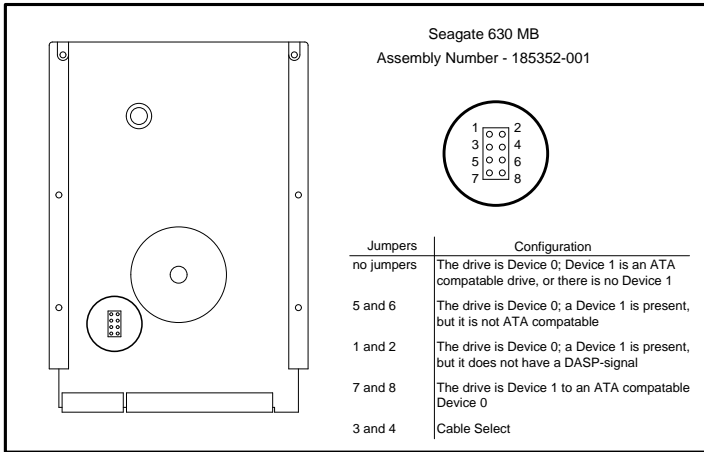


Figure 6-7. 630-MB Seagate IDE Hard Drive Jumper Settings

6.3.2 1.08-GB IDE Hard Drive Jumper Settings

The jumper settings for the 1.08-GB IDE are shown below.

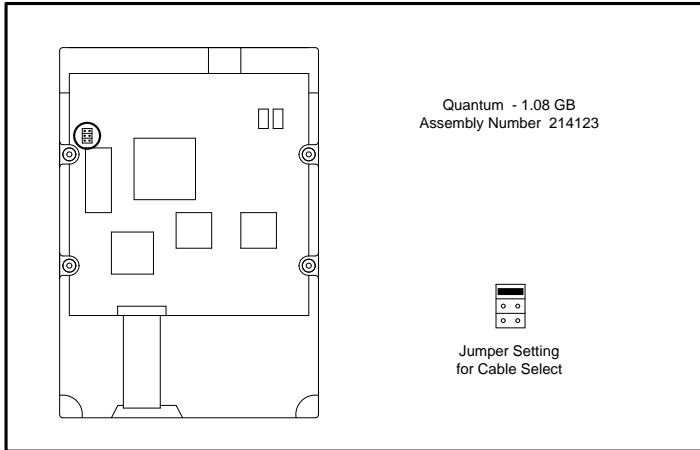


Figure 6-8. 1.08-GB Quantum IDE Hard Drive Jumper Settings

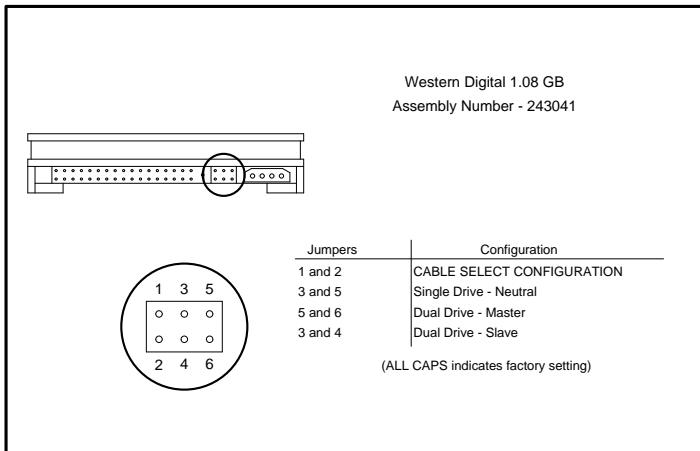


Figure 6-9. 1.08-GB Western Digital IDE Hard Drive Jumper Settings

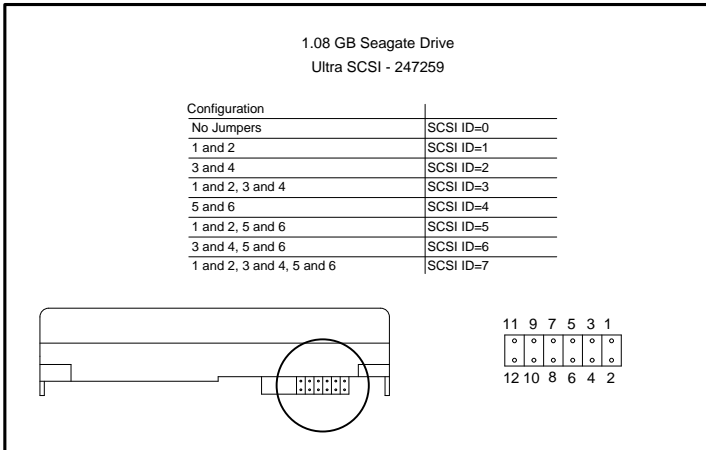


Figure 6-10. 1.08-GB Seagate Ultra SCSI Hard Drive Jumper Settings

6.3.3 1.2-GB IDE Hard Drive Jumper Settings

The jumper settings for the 1.2-GB IDE hard drive are shown below.

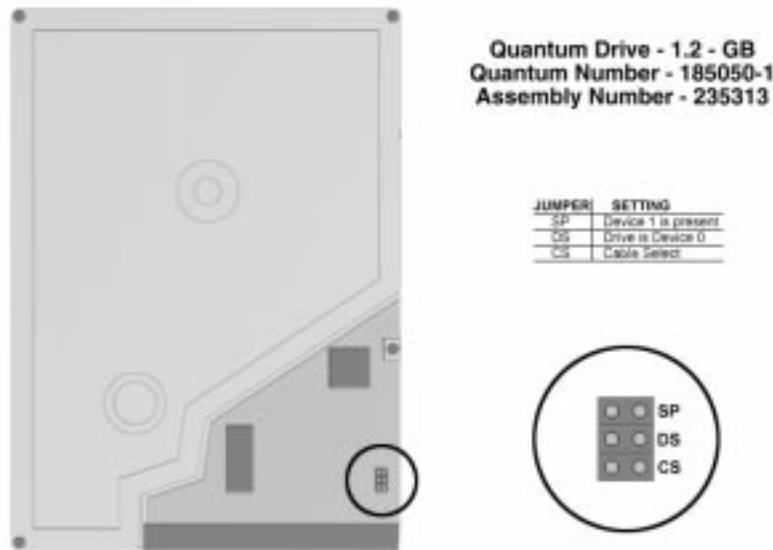


Figure 6-11. 1.2-GB (5.25") Quantum IDE Hard Drive Jumper Settings

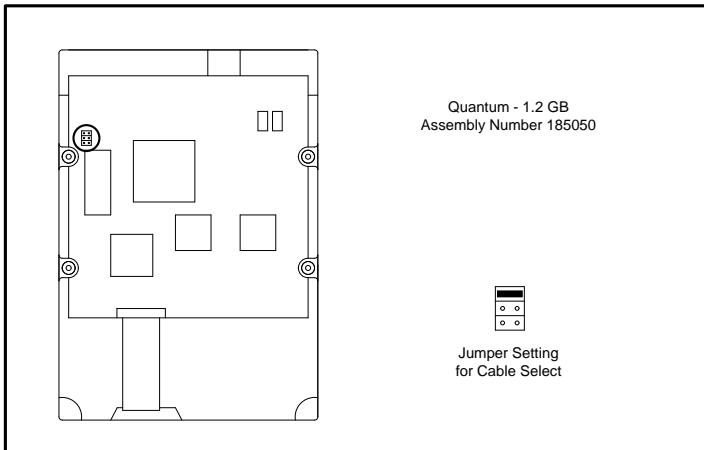


Figure 6-12. 1.2-GB (3.5") Quantum IDE Hard Drive Jumper Settings

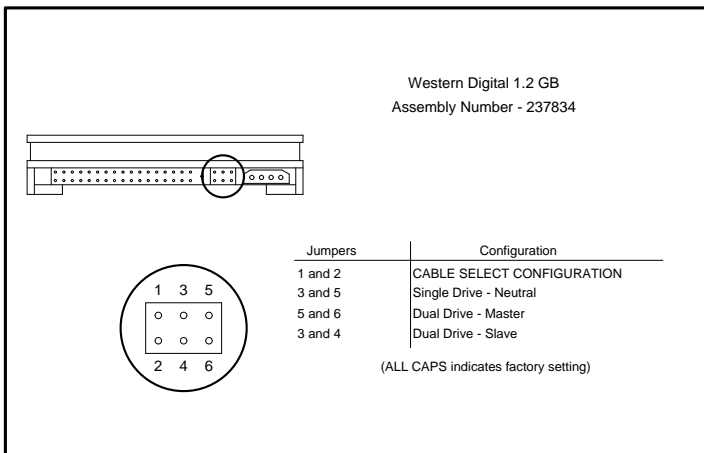


Figure 6-13. 1.2-GB (3.5") Western Digital IDE Hard Drive Jumper Settings

6.3.4 1.62-GB IDE Hard Drive Jumper Settings

The jumper settings for the 1.62-GB IDE hard drive are shown below.

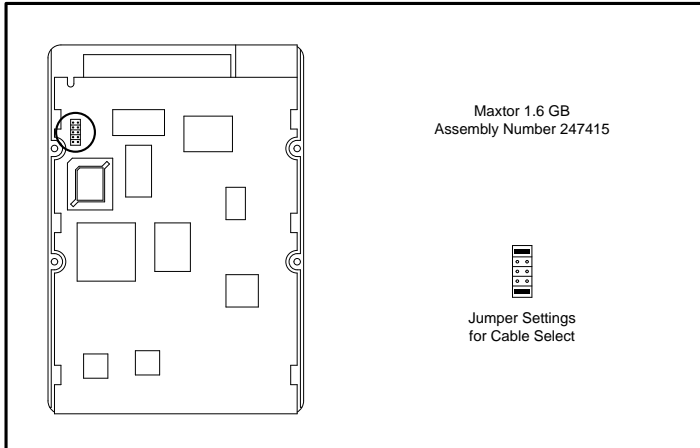


Figure 6-14. 1.62-GB Maxtor IDE Hard Drive Jumper Settings

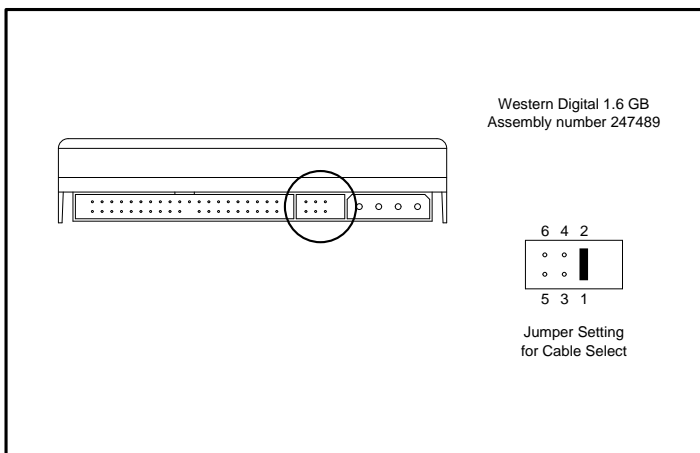


Figure 6-15. 1.62-GB Western Digital IDE Hard Drive Jumper Settings

6.3.5 2.0-GB IDE Hard Drive Jumper Settings

The jumper settings for the 2.0-GB IDE hard drive are shown below.

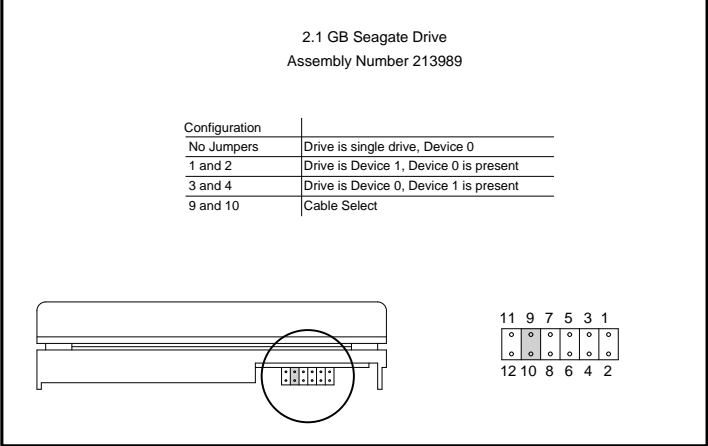


Figure 6-16. 2.0-GB Seagate IDE Hard Drive Jumper Settings

6.3.6 2.5-GB IDE Hard Drive Jumper Settings

The jumper settings for the 2.5-GB IDE hard drive are shown below.

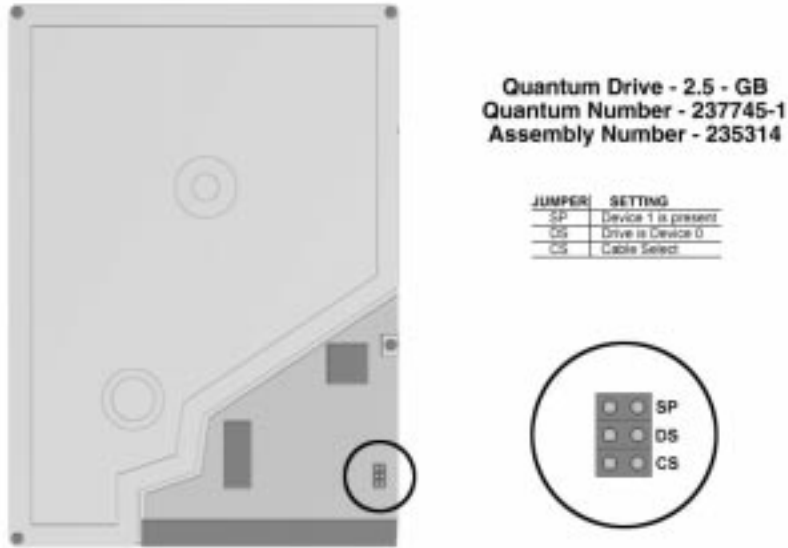


Figure 6-17. 2.5-GB IDE Hard Drive Jumper Settings

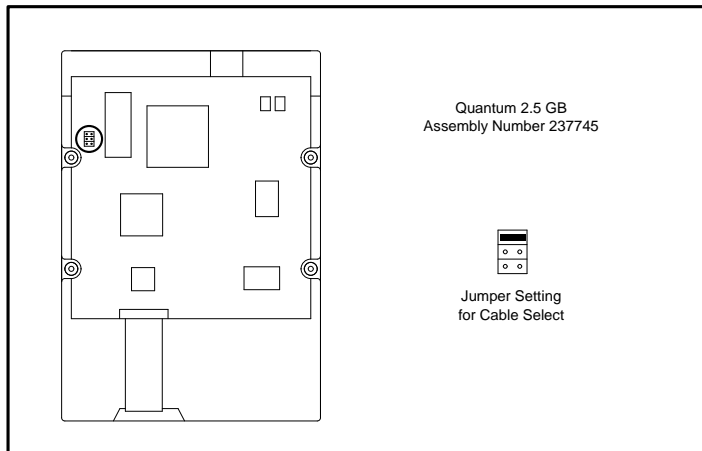


Figure 6-18. 2.5-GB (3.5") IDE Hard Drive Jumper Settings

6.3.7 1.0-GB SCSI Hard Drive Jumper Settings

The jumper settings for the 1.0-GB SCSI hard drives are shown below.

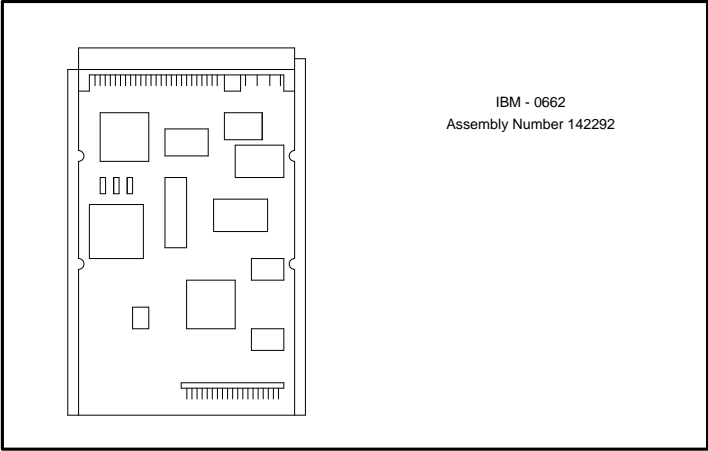


Figure 6-19. 1.0-GB SCSI IBM Hard Drive Jumper Settings

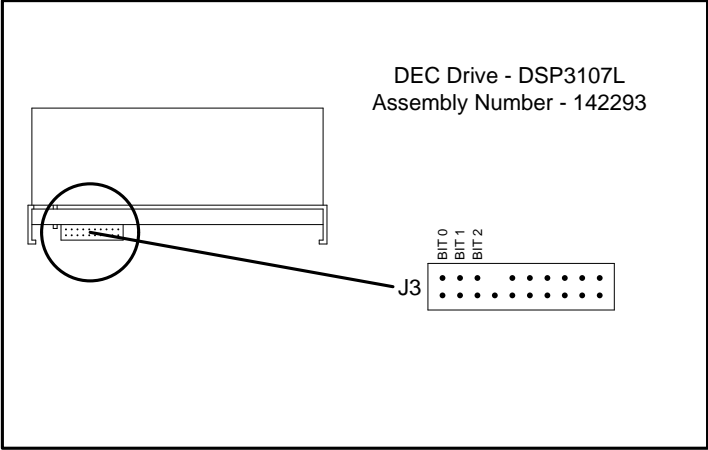


Figure 6-20. 1.0-GB SCSI DEC Hard Drive Jumper Settings

6.3.8 2.1-GB Ultra SCSI Hard Drive Jumper Settings

The jumper settings for the 2.1-GB Ultra SCSI hard drive are shown below.

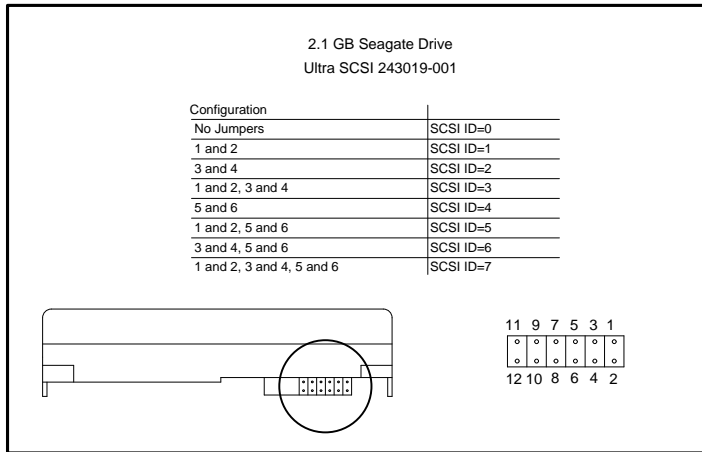


Figure 6-21. 2.1-GB Ultra SCSI Hard Drive Jumper Settings

6.4 CD-ROM Drive Jumper Settings

The jumper settings for the 8X IDE CD-ROM drives are shown below.

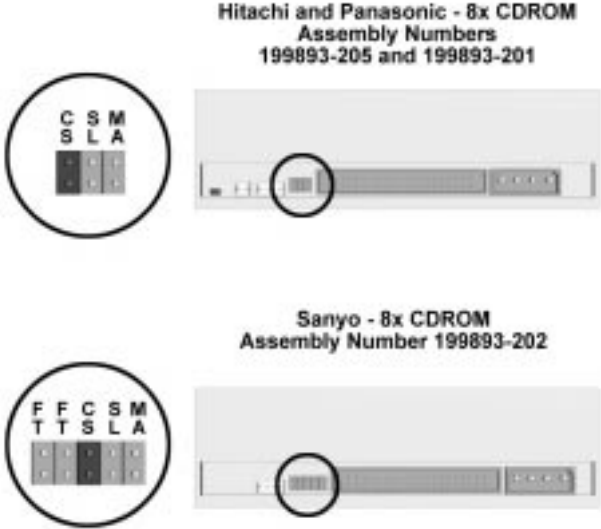


Figure 6-22. Jumper Positions for the 8X IDE CD-ROM Drives

6.5 PD-CD Drive Jumper Settings

The jumper settings for the PD-CD drive are shown below.

PD/CDROM - SCSI
Assembly Number 184689-201

Jumper	Description	Setting
1	LUN enabled	Off
2	SCSI ID jumper	On
3	SCSI ID jumper	Off
4	SCSI ID jumper	On
5	Blank	Not Used
6	Terminators disabled	Off
7	Term power enabled	On

Figure 6-23. Jumper Positions for the PD- CD Drive

chapter 7

COMPAQ UTILITIES

This chapter contains descriptions of Compaq utilities that can be helpful when servicing the Compaq Deskpro 2000 Series of Personal Computers. These utilities include:

- Configuring Graphics Displays and Monitor
- Power Management utility
- Security Management Features
- Flash ROM

See Chapter 2 for more information on the Configuration and Diagnostics utilities and the power-on password.

7.1 Configuring Windows Display and Monitor

When you first set up the computer and monitor, the setup utility communicates with the monitor to automatically detect the monitor type, select the best display configuration, and install the appropriate display drivers. This automated setup is referred to as Plug and Play; there are no switches to set or manual procedures to follow; just plug it in.

- ✎ A monitor with AssetControl is required for the Plug and Play setup to work. If you do not have a Plug and Play monitor, you can set up the display manually.

Supported Resolutions

Resolutions supported by the graphics controllers installed on the Compaq Deskpro 2000 Series of Personal Computers are presented in Chapter 8, "Specifications."

For more information on upgrading the graphics memory, refer to Chapter 5, "Removal and Replacement Procedures."

7.1.1 Changing Monitor Type Manually in Windows 3.1 and Windows NT

The setup utility automatically detects Plug and Play monitor types, but if you are not using a Plug and Play monitor, you can manually select or change the monitor type. The procedure varies slightly for each graphics controller in Windows 3.1 and Windows NT.

- ✎ If you are not sure which graphics controller is installed on the computer, run Compaq Diagnostics to identify the installed controller.

PCI Performance Graphics Controller

If the computer has a PCI Performance Graphics Controller, complete the following steps to change the monitor type:

1. Select the Winmode icon from the Compaq Utilities Group Box. This launches a window showing the current configuration of your computer.
2. Select the desired monitor brand and model from the list of monitors displayed.
3. Close the Winmode utility and exit Windows. When you restart Windows, Windows will be configured appropriately for the monitor.
4. Click on the Change Display Settings button to view change options.

Matrox MGA Millennium Graphics Controller

Use the MGA Panel to select a monitor type, configure 3D accelerations, and obtain information about the MGA Millennium graphics controller installed in your computer.

To access the MGA Panel, double-click the MGA Panel icon, located in the Microsoft Windows NT Control Panel.

Monitor Tab

If the computer has a Matrox MGA Millennium Graphics Controller, complete the following steps to change the monitor type:

1. Click the Monitor tab in the MGA Panel.
2. If you have multiple graphics controllers or monitors installed, choose the Millennium board ID first, at the upper-right corner of the page.
3. Select the monitor controlled by the Millennium graphics controller.
4. Perform this procedure for each graphics controller that you have installed.
5. Click Save and restart your computer when prompted to do so.

Configuration Tab

Use Configuration to select 3D acceleration and language preferences. Complete the following steps:

1. Click the Configuration tab in the MGA Panel.
2. Enable 3D acceleration preferences (Z Buffer, Double Buffer, or Sub Pixel Precision) by clicking to place an arrow in the appropriate box or boxes.

3. Disable 3D acceleration preferences by clicking to remove the arrow from the appropriate box or boxes.
4. Select your language preference for the MGA Panel text by choosing the appropriate language in the language box.

Information Tab

Use Information to obtain MGA Millennium hardware information, including the following:

- graphics controller board type
- graphics controller board serial number
- amount of video memory (WRAM)
- video BIOS version
- memory mapping
- RamDAC speed

About Tab

Use About to obtain MGA Millennium software information, including the following:

- graphics controller driver version
- current resolution settings
- current pixel depth settings
- current refresh rate settings
- ✍ The screen refresh rate is dependent on the monitor chosen and it changes to correspond with the monitor you have selected.
- available 3D acceleration settings

7.1.2 Changing Monitor Type Manually in Windows 95

If you are using Windows 95, the operating system automatically recognizes all Plug and Play monitors. If you are not using a Plug and Play monitor, proceed to the following steps to select your monitor and screen refresh rate.

PCI Performance Graphics Controller

If the computer has a PCI Performance Graphics Controller, complete the following steps to change the monitor type:

1. Click on the Control Panel.
2. Click on the Display icon.
3. Click on Settings to change the display type.

7.1.3 Setting Graphics Resolution

The quality of the picture you see depends on the resolution of the monitor and the number of colors that are displayed. Although the setup utility automatically selects the display configuration, you can manually change the resolution to match a software program or to suit personal preferences. The procedure varies slightly for each graphic controller.

- ✎ If you are not sure which graphics controller is installed on the computer, run Compaq Diagnostics to identify the installed controller.

PCI Performance Graphics Controller - Windows 95

Complete the following steps to change the resolution:

1. Click on the Control Panel.
2. Click on the Display icon.
3. Click on Settings to change the graphics resolution.

PCI Performance Graphics Controller - Windows 3.1


Complete the following steps to change the resolution:

1. Select the Winmode icon from the Compaq Utilities Group Box.
This launches a window showing the current configuration of your computer.
2. Select a resolution from the list of resolutions.
The resolutions available from the list are those supported by the selected monitor type.
3. Close the Winmode utility and exit Windows.
When you restart Windows, the new resolution will be activated.

Matrox MGA Millennium Graphics Controller - Windows 3.1

Complete the following steps to change the graphics resolution:


1. From the MGA Millennium PowerDesk group box, select the Control Panel icon.
2. Click on a Mode Setup button (1 through 4).
3. Select the appropriate display, desktop, colors, and fonts from the options provided, then click OK.
4. Restart Windows to activate the new display options.

 If you click the Use ModeSWITCH check box and restart Windows, you can switch among the four display modes without restarting Windows every time.

Matrox MGA Millennium Graphics Controller - Windows 95

Complete the following steps to change the graphics resolution:

1. Click the Start button, and point to Properties.
2. Choose MGA Settings.
3. Select the appropriate display, desktop, colors, and fonts from the options provided, then click OK.
4. Restart Windows to activate the new display options.

 If you click the Use ModeSWITCH check box and restart Windows, you can switch among the four display modes without restarting Windows every time.

7.1.4 Ordering Operating System Device Drivers

If you plan to run the IBM OS/2 or SCO UNIX operating system with the graphics controller, you must install the corresponding graphics controller device drivers before attempting to use the computer. To order appropriate device drivers, contact Compaq Customer Support.

7.2 Power Management Utility

Power Management is a combination of hardware and software components that allows you to conserve power when your computer is turned on but not in use. The computer can be set to go into the Energy Saver mode after a specified period of inactivity and return to full power mode when user activity at the keyboard or mouse is detected. Power Management is available under the Windows environment, and some features are available under the MS-DOS environment. To take full advantage of the Power Management features, you must be using an Energy Star monitor.

7.2.1 Power Management Features

- ✎ The Power Management components are features of the computer; however, for full Power Management benefits, the computer must be connected to a monitor that has power conservation features.

Table 7-1
Power Management Features

Feature	Purpose	How It Is Established in Computer Setup
Energy Saver Mode	Allows PC to go into a reduced power state.	Energy Saver (Default=OFF)
Energy Saver Timeouts	Allows user to select timeout values for hard drive and/or monitor. Hard drive and monitor timeouts may be set independently of each other.	Energy Saver: Monitor Default=15 min.; System unit Default=30 min.
Energy Saver Light	Allows optional blinking of system unit Power-On light when PC is in Energy Saver mode.	Blink LED

7.2.2 Setting Power Management Values in Windows 3.1

To access Power Management under the Windows 3.1 environment:

1. Select the Power Management icon in the Compaq Control Center. Power Management can also be found in the Compaq Utilities group box of Windows Program Manager.
2. In the Energy Saver dialog box, check ON to activate Energy Saver. Indicate whether you have an Energy Star monitor
3. Set a timeout value for the system by entering a value ranging from 15 to 75 minutes (the default is 30 minutes).

If you have an Energy Star monitor, set a timeout value for the monitor by entering a value ranging from 5 to 60 minutes (the default is 15 minutes).

4. Click on OK, and the timeout values you set will take effect the next time you start your computer.

A dialog box displays, giving you the opportunity to restart your computer immediately. Or you may decide to wait for a more convenient time.

7.2.3 Setting Power Management Values in Windows 95

To access Power Management in the Windows 95 environment:

1. Click on the Control Panel.
2. Click on the Power icon.
3. Follow the instructions on the screen to set Power Management features.

7.2.4 Setting Power Management with Other Operating Systems

To access Power Management, use Computer Setup.

7.3 Security Management

The Compaq Deskpro 2000 Series of Personal Computers offers security features that provide solutions for a variety of potential concerns. Use Security Management in the following instances:

- To set, change, or delete the power-on password.
- To set, change, or delete the setup password, which protects the computer's configuration.
- To set the power-on password, when prompted, after turning on the computer.
- To set or change QuickLock/QuickBlank features.
- To enable or disable the diskette drive.
- To enable or disable diskette boot ability.
- To enable or disable diskette write control.
- To enable or disable the serial or parallel ports.
- ✍ Windows 95 also has security features. For more information, see Passwords in the Control Panel.
- ✍ Security features will vary, depending on the model.

For more information on the Configuration and Diagnostics menu, and on accessing the Security Management utility by using **F10** after the Power-On Self Test, see Chapter 2.

7.3.1 Security Features

The security features provided are presented in Table 7-2. These features must be used in combination with a power-on password.

**Table 7-2
Security Features**

Feature	Purpose	How It Is Established
SETUP Password	Allows configuration to be changed.	Computer Setup
Power-On Password	Prevents use of the computer when the computer boots up unless the password is entered.	Computer Setup
Windows 95 Password	Prevents use of the computer when Windows 95 starts up unless the Windows 95 password is entered or the computer has just booted and the power-on password was entered.	Control Panel Passwords
Logon Password	Prevents use of the computer unless password is entered.	Windows NT Security (Not applicable in Windows 3.1 or Windows 95)
QuickLock/QuickBlank*	Disables keyboard and can blank the screen without exiting application; enabled with a password.	Computer Setup
Diskette Boot Control*	Prevents startup from diskette drive.	Security Management or Computer Setup
Diskette Write Control*	Prevents writing to the diskette drive. Allows Read only.	Security Management or Computer Setup
Serial Interface Control*	Prevents transfer of data through the integrated serial interface.	Computer Setup. Also available through Windows 95 Device Manager.
Parallel Interface Control*	Prevents transfer of data through the integrated parallel interface.	Computer Setup. Also available through Windows 95 Device Manager.
Removable Media Control	Prevents startup from the removable media drives.	Computer Setup
Removable Media Control	Prevents writing to the removable media drives. Allows read only.	Computer Setup
Flash ROM Lock	Prevents Flash ROM updates.	ROMPaq and Setup Password required to update ROM
Cable Lock Provision	Inhibits access to the interior of the computer to prevent unwanted configuration changes or component removal. Can also be used to secure the computer to a fixed object.	Optional hardware. Install a padlock with the security bracket to inhibit access to the interior of the computer; add a cable lock to secure the computer to a fixed object.

*Must be used in combination with a power-on password.

- ✍ For information on accessing Security Management and establishing a power-on password, see "Using the Power-On Password Feature" in this section.
- ✍ Windows 95 and Windows NT can override some security features you set through the Compaq Utilities menu at startup. Because of this, Compaq recommends that you set your passwords by using the Windows 95 Password icon or the Windows NT Security icon, located in the Control Panel.

7.3.2 Establishing a Password in Windows 95

To establish a password in Windows 95, complete the following steps:


1. Go to the Control Panel.
2. Double-click the Passwords icon and follow the instruction to set a new password.

7.3.3 Establishing a Password in Windows NT

To establish a password in Windows NT, complete the following steps:


1. Go to the Control Panel.
2. Select the Security icon and follow the instruction to set a new password.

7.3.4 Establishing a Power-On Password Using Computer Setup

Establishing a power-on password through Computer Setup prevents access to the computer when power is turned on, unless the password is entered. The password must be entered each time the computer is turned on, when the key icon () appears on the monitor.

To establish a power-on password through Computer Setup complete the following steps:


1. Turn on the computer.
2. When the cursor appears in the upper-right corner of the screen, press the **F10** key.


 The cursor displays in the upper-right corner of the screen for approximately two seconds. If you do not press the **F10** key during this time, you must turn the computer off, then on again to access the utility.


3. Press the Enter key to bypass the welcome screens and display the main menu.
4. From the main menu, select Computer Setup, and press the Enter key.
5. Select the Security Management feature.
6. Locate the power-on password option and follow the instructions provided to enable it.
7. Save the configuration and exit the utility.

7.3.5 Entering a Power-On Password

To enter the power-on password, complete the following steps:


1. Turn on the computer.
2. When the key icon () appears on the monitor, enter your current password.

 Type carefully; for security reasons, the characters you type do not appear on the screen.


If you enter the password incorrectly, a broken key icon () appears. Try again. After three unsuccessful tries, you must turn off the computer, then turn it on again before you can continue.


7.3.6 Changing a Power-On Password

To change the password, complete the following steps:

1. Turn on the computer.
2. When the key icon () appears, type your current password, a slash (/) or alternate delimiter character, your new password, another slash (/) or alternate delimiter character, and your new password again as shown:

current password/new password/new password


 Refer to the “National Keyboard Delimiter Characters” section in this chapter for information about the alternate delimiter characters.

 Type carefully; for security reasons, the characters you type do not appear on the screen.


Completing this procedure causes the new password to take effect the next time you turn on the computer.

7.3.7 Deleting a Power-On Password

To delete the password, complete the following steps:

1. Turn on the computer.
2. When the key icon () appears, type your current password followed by a slash (/) or alternate delimiter character as shown:

current password/

 Refer to the “National Keyboard Delimiter Characters” section in this chapter for information about alternate delimiter characters.

Completing this procedure deletes the password until you establish a new one through Security Management.


7.3.8 National Keyboard Delimiter Characters

Each keyboard is designed to meet country-specific requirements. The syntax and keys that you use for changing or deleting your password depend on the keyboard that came with your computer.

To determine the delimiter key required for changing or deleting your password, find your keyboard in the table below:

National Keyboard Delimiter Characters			
Arabic	/	Greek -	Slovakian -
Belgian	=	Hungarian -	Spanish -
BHCSY*	-	Italian -	Swedish/Finnish /
Brazilian	/	Japanese /	Swiss -
Chinese	/	Korean /	Taiwanese /
Czech	-	Latin American -	Thai /
Danish	-	Norwegian -	Turkish .
French	!	Polish -	U.K. English /
French Canadian	é	Portuguese -	U.S. English /
German	-	Russian /	

* For Bosnia-Herzegovina, Croatia, Slovenia, and Yugoslavia

 To clear power-on password, see Chapter 2, "Troubleshooting."

7.4 Advanced Security Management

The following security features can be accessed through the Computer Setup option on the Compaq Utilities menu.

- Storage
 - Disable removable media boot ability
 - Disable removable media write ability
- Communication
 - Disable serial port
 - Disable parallel port
- Security Management
 - QuickLock/QuickBlank

7.4.1 QuickLock/QuickBlank

The QuickLock and QuickBlank features can disable the keyboard and mouse interfaces and blank the screen while an application is open. The feature is enabled with a power-on password. If QuickBlank is also enabled, the screen blanks. When this feature is used, the computer is secure until you enter the power-on password.

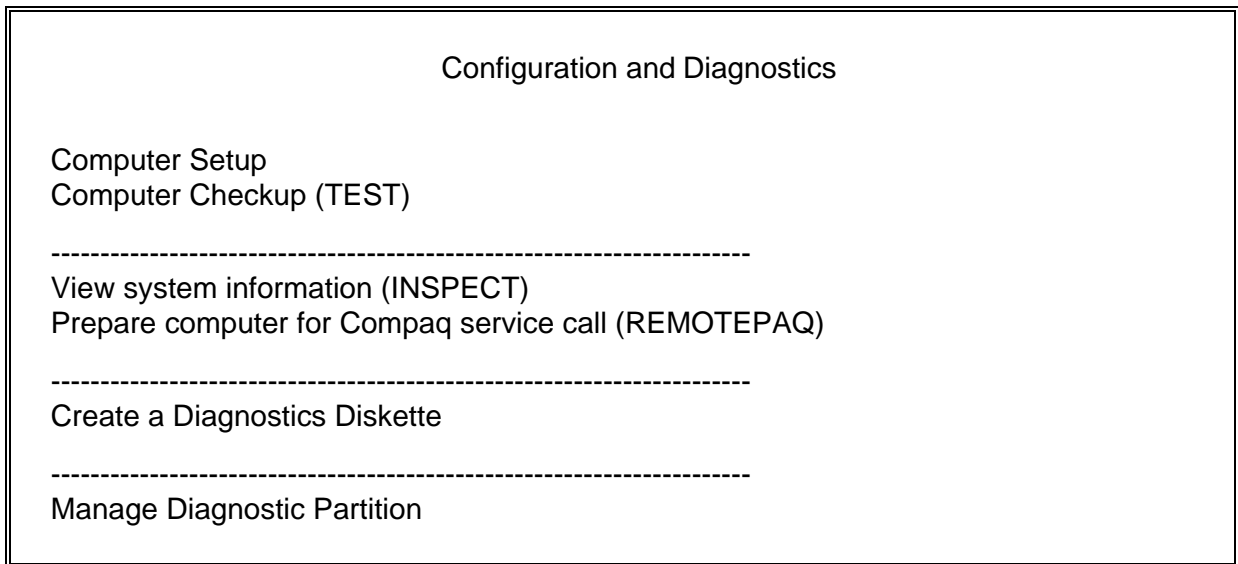
Enabling QuickLock/QuickBlank

QuickLock and QuickBlank are enabled through Security Management. The keyboard and mouse interface can be disabled and the screen blanked from within an application. Entering a QuickLock key combination (**Ctrl+Alt+L**) disables the keyboard and the mouse interface. If QuickBlank is not activated, the application remains in view on the screen, but it cannot be accessed.

To re-enable the input device interface and access the application, the user must enter the power-on password that the user established in Security Management.

To enable the QuickLock and QuickBlank features from the Configuration and Diagnostics Menu, complete the following steps:

1. Turn on the computer.
2. When the cursor appears in the upper-right corner of the screen, press **F10**.
✎ The cursor displays in the upper-right corner of the screen for approximately 2 seconds. If the user does not press **F10** during this time, the user must turn the computer off, then on again to access the utility.
3. Press **Enter** to bypass the welcome screens and display the main menu.



4. From the main menu, select Computer Setup and press **Return** or click with the mouse.
5. From the main menu, select the **Security Management** feature, and press **Enter**.
6. When the steps in the **Security Management** screen display, select **View or Edit Details** and press **Enter** or click with the mouse.
7. Page down to locate the QuickLock password and QuickBlank items on the screen and follow the instructions provided to enable them.
8. Save the configuration and exit the utility.

7.4.2 Keyboard and Mouse Interface

Disabling the Keyboard and Mouse Interface

Once in an application, enter the QuickLock key combination (**Ctrl+Alt+L**). The keyboard and mouse (or other input device connected to the mouse connector) are disabled. The application cannot be accessed at this time, but remains in view, unless the QuickBlank feature was also enabled through the Configuration utility.

Enabling the Keyboard and Mouse Interface

To enable the keyboard and input device connected to the mouse connector, enter the password.

- ✎ For security reasons, the characters the user types do not appear on the screen. The application will not be affected by the characters typed.

7.5 Flash ROM

The Compaq Deskpro Personal Computer comes with re-programmable Flash ROM (Read Only Memory). Flash ROM, set to its default setting of OFF, protects the Flash ROM from being upgraded and the System BIOS from being updated.

To update the ROM, order the ROMPaq diskette from Compaq. To upgrade the ROM, complete the following procedures:

1. Insert the ROMPaq diskette into the floppy drive, enter the correct command, and the computer prompts for the Setup Password (if set).



CAUTION: If the computer does not have a Setup Password enabled, then the ROM is not write-protected and unauthorized updates can occur. The Setup Password is disabled when the computer is shipped from the factory.

2. If prompted, enter the Setup Password.
3. If the Setup Password is entered correctly, the ROMPaq utility takes over and runs the flash ROM upgrade.
- ✎ If the Setup Password is entered incorrectly, the procedure terminates and no changes are made to the ROM.
- ✎ Do not turn off the power to your computer until the ROMPaq utility has completed the upgrade process.
4. When the utility has finished upgrading the ROM, remove the diskette from the diskette drive and reboot the computer.

7.6 Intelligent Manageability

Intelligent Manageability combines innovative hardware technology with PC LAN management tools from Compaq and other leading vendors to make Compaq Deskpro computers easier to inventory, troubleshoot, and protect. Intelligent Manageability features focus on Asset Management, Fault Management, and Security Management.

- ✎ For non-Windows environments, AssetControl, Fault Management, and Security Management features are available through the View System Information (INSPECT) utility at computer startup.

The Deskpro 2000 Series of Personal Computers has integrated desktop management features, including AssetControl and Fault Management.

By running Compaq Diagnostics or Diagnostics for Windows and selecting the AssetControl icon, you can view information about the computer such as monitor serial number and monitor timing, system and hard drive serial numbers, as well as other features. This information is useful for identifying internal components and for setting up and maintaining inventory lists, especially over network installations.

- ✎ To access the monitor information file, your computer must be connected to a monitor that has AssetControl capabilities.

Fault Management is the monitoring of two critical subsystems, the IntelliSafe hard drive and thermal status. If the status of either of these subsystems degrades, Diagnostics will reflect the change. This information is useful for early failure detection and troubleshooting.

In most cases, the software required to take full advantage of the computer's Intelligent Manageability features has been pre-installed. However, should you need to install the software from a diskette:

1. Insert the Compaq Insight Management Agents for Microsoft Windows 95 setup diskette into drive A.
2. Run A:\SETUP.EXE.
3. If the computer is connected to a network managed by Compaq Insight Manager, configure the computer for Insight Manager.
4. Restart the computer.

- ✎ You must restart the computer for the changes to take effect.

7.6.1 Asset Management

Conducting a physical inventory of personal computers, key components, and monitors can be time-consuming and costly. AssetControl is Compaq's asset management solution, designed and built into new Deskpro computers, key components, and monitors that support the VESA DDC and EDID standards.

Compaq's AssetControl features make it easy to maintain an accurate, up-to-date inventory and help to lower the cost of ownership. Detailed inventory information, including manufacturer, model, serial number of the computer's hard drive and monitor, asset tag, and ROM revision level can be viewed, printed, or saved electronically using Compaq Insight Personal Edition, Compaq Insight Manager, and network management products from the Compaq Desktop Management Solutions Partners.

AssetControl features:

- Simplify and help to ensure accuracy of inventory and accounting procedures.
- Allow the system administrator to identify software and revision levels remotely.
- Streamline service calls by giving the administrator fast access to the Deskpro's configuration and history.

7.6.2 Fault Management

All new Deskpro personal computers include Fault Management features combining innovative hardware and software technology to prevent the loss of critical data and minimize unplanned downtime.

- The IntelliSafe Hard Drive constantly monitors hard drive activity to predict failures before they occur. Fault prediction and failure indication parameters, such as abnormal variations in spin-up and seek times, or non-correctable read and write errors, are tracked to determine the hard drive condition. Should these errors become significant, the computer displays a warning message – giving you time to back up the hard drive and replace it prior to experiencing downtime or loss of data.
- Proactive Tape Backup software automatically initiates a tape backup upon receiving notice of an impending hard drive failure.
- Network Performance Monitoring, in conjunction with Compaq Insight Manager, allows the system administrator to predict failure of the integrated NIC by monitoring and analyzing NIC performance data.

Compaq Insight Personal Edition automatically displays a pop-up dialog to notify you when a hard drive or system temperature fault is detected. If the computer is connected to a network managed by Compaq Insight Manager, fault notices are also sent to the network management application.

7.6.3 Compaq Insight Personal Edition

Compaq Insight Personal Edition:

- Enables viewing of AssetControl information locally.
- Automatically displays a pre-failure warning message upon detecting a hard drive or system temperature fault.
- Enables viewing of hardware and software configuration information.

To run Compaq Insight Personal Edition:

1. Go to the Control Panel.
2. Double-click the Compaq Insight Personal Edition icon.

7.6.4 Compaq Insight Manager

Insight Manager is the Compaq application for easily managing servers and personal computers on a network. Insight Manager delivers intelligent monitoring and alerting, remote maintenance, and visual control of network resources.

Compaq Insight Management Agents for Microsoft Windows 95 operates on Deskpro personal computers, monitoring the health of the system and generating alert notifications for the system administrator if a fault is detected.

7.6.5 Changing the Default Configuration

To change the default configuration settings, run the Configuration utility. Refer to Chapter 2, "Troubleshooting," for more information.

chapter 8

SPECIFICATIONS

This chapter provides physical, environmental, and performance specifications for the computer, keyboard, and mass storage devices.

8.1 System

**Table 8-1
System Specifications**

	U. S.	Metric
Desktop Dimensions		
Height	5.1 in	12.85 cm
Width	15.8 in	40.00 cm
Length	17.6 in	44.78 cm
Minitower Dimensions		
Height	18.6 in	47.17 cm
Width	7.3 in	18.54 cm
Depth	17.1 in	42.37 cm
Weight		
Desktop Model	23.7 lb	10.74 kg
Minitower Model	34.0 lb	15.40 kg
Power Supply		
Desktop Model		
Operating Voltage Range	90-132 VAC	180-264 VAC
Rated Voltage Range	100-120 VAC	220-240 VAC
Rated Line Frequency	50 - 60 Hz	50 - 60 Hz
Minitower Model		
Operating Voltage Range	90-132 VAC	180-264 VAC
Rated Voltage Range	100-120 VAC	220-240 VAC
Rated Line Frequency	50 - 60 Hz	50 - 60 Hz
Rated Input Current (maximum)	5 A	3 A
Power Output		
Desktop:	200 W	200 W
Minitower	200 W	200 W
Environmental Requirements		
Temperature		
Operating	50° to 95°F	10° to 35°C
Shipping	50° to 122°F	10° to 50°C
Humidity (noncondensing)		
Operating	8% to 90%	8% to 90%
Nonoperating	5% to 95%	5% to 95%
Maximum Altitude (unpressurized)		
Operating	10,000 ft	3048 m
Nonoperating	30,000 ft	9144 m
Heat Dissipation (nominal)		
Desktops	770 Btu/hr	3.23 kg-cal/min
Minitower	1060 Btu/hr	4.45 kg-cal/min

**Table 8-2
System Interrupts**

Hardware IRQ	System Function
IRQ 0	Timer Interrupt (Not on ISA Bus)
IRQ 1	Keyboard (Not on ISA Bus)
IRQ 2	Interrupt Controller Cascade (Not on ISA Bus)
IRQ 3	Unused
IRQ 4	Serial Port (COM 1)
IRQ 5	Enhanced Business Audio*
IRQ 6	Diskette Drive
IRQ 7	Parallel Port (LPT 1)
IRQ 8	Real-Time Clock (Not on ISA Bus)
IRQ 9	Unused
IRQ 10	Unused
IRQ 11	PCI Interrupt
IRQ 12	Mouse
IRQ 13	Coprocessor (Not on ISA Bus)
IRQ 14	IDE Interface (Hard Disk and Primary IDE Drive)
IRQ 15	CD-ROM (Secondary IDE/Drive)

*Default configuration; other configurations = IRQ7, IRQ9, IRQ10, None

**Table 8-3
System DMA**

Hardware DMA	System Function
DMA 0	Unused
DMA 1	Business Audio (Default; Alternate = DMA0, DMA3, None)
DMA 2	Diskette Drive
DMA 3	ECP Parallel Port LPT1 (Default; Alternate = DMA 0)
DMA 4	DMA Controller Cascading (Not on ISA Bus)
DMA 5	Unused
DMA 6	Unused
DMA 7	Unused

**Table 8-4
System I/O**

I/O Address (Hex)	System Function (Shipping Configuration)
000 - 00F	DMA Controller # 1
010 - 01F	Unused
020 - 03F	Interrupt Controller # 1
040 - 043	Counter/Timer
044 - 05F	Unused
060	Keyboard Controller
061	Port B
062 - 063	Unused
064	Keyboard Controller
065 - 06F	Unused
070 - 071	NMI Enable/Real-Time Clock
072 - 07F	Unused
080 - 08F	DMA Page Registers
090 - 091	Unused
092	Port A
093 - 09F	Unused
0A0 - 0BF	Interrupt Controller # 2
0C0 - 0DF	DMA Controller # 2
0E0 - 0EB	Unused
0EC - 0ED	483 Configuration Index/Data
0EE - 0EF	483 Fast A20/Fast Reset
0F0 - 0F1	Co-Processor Busy Clear/Reset
0F2 - 0F3	Unused
0F4 - 0F5	483 CPU Speed Slow/Fast
0F6 - 0F8	Unused
0F9	483/PGL Configuration Lock
0FA	Unused
0FB	483/PGL Configuration Unlock
0FC - 0FF	Unused
100 - 12F	Unused
130 - 131	Modem PGL Index/Data (Default; Alt = 140h, 260h, 270h)
132 - 16F	Unused
170 - 177	Reserved
178 - 1EF	Unused
1F0 - 1F7	Fixed Disk Controller
1F8 - 1FF	Unused
200	Unused
201	Unused

Continued

Table 8-4 *Continued*

I/O Address (Hex)	System Function (Shipping Configuration)
202 - 21F	Unused
220 - 22F	Business Audio (Default; Alter =230h, 240h, 250h)
230 - 277	Unused
278 - 27F	Reserved Parallel Port
280 - 2E7	Unused
2E8 - 2EF	Reserved Serial Port
2F0 - 2F7	Unused
2F8 - 2FF	Modem (COM 2)
300 - 317	Unused
318 - 319	Unused
31A - 36F	Unused
370 - 377	Reserved (2nd Diskette Drive)
378 - 37F	Parallel Port (Primary)
380 - 387	Unused
388 - 38B	FM Synthesizer - OPL3
38C - 397	Unused
398 - 399	Super AI/O Index/Data (Default; Alt = 26Eh, 15Ch, 02Eh)
39A - 3AF	Unused
3B0 - 3BB	MDA, EGA/VGA
3BC - 3BF	Reserved (Parallel Port)
3C0 - 3DF	EGA/VGA
3E0 - 3E7	Unused
3E8 - 3EF	Reserved (Serial Port)
3F0 - 3F7	Diskette Controller
3F8 - 3FF	Serial Port (Primary)

**Table 8-5
System Memory Map**

Size	Memory Address	System Function
256 KB	FFFFFFFh to FFFC0000h	System ROM
2,080,384 KB	FFFBFFFFh to 81000000h	PCI Memory Expansion
16 MB	80FFFFFFh to 80000000h	ISA Memory Mapped I/O Devices
1792 MB	7FFFFFFFh to 10000000h	PCI Memory Expansion
240 MB	0FFFFFFFh to 01000000h	HOST or PCI Memory Expansion
15 MB	00FFFFFFh to 00100000h	HOST, PCI, or ISA Memory Expansion
64 KB	00EFFFFh to 000F0000h	System ROM
64 KB	000EFFFFh to 000E0000h	Unused
96 KB	000DFFFFh to 000C8000h	Unused
6 KB	000C7FFFh to 000C6000h	Video ROM
2 KB	000C67FFh to 000C6000h	Unused
24 KB	000C5FFFh to 000C6000h	Video ROM
128 KB	000BFFFFh to 000A0000h	Video RAM
640 KB	0009FFFFh to 00000000h	Base Memory

All memory above the first 256 MB is non-cacheable. All PCI memory is non-cacheable.


8.2 Drives

**Table 8-6
Diskette Drives**

	1.44 MB	120 MB
Size and Capacity		
Size (in)	3.5	3.5
High Density (MB)	1.44	120
Low Density (KB)	720	n/a
Light	Green	Green
Height	One-third	One-third
Bytes per Sector	512	512
Sectors per Track		
High Density	18	51-93
Low Density	9	8
Tracks per Side		
High Density	80	1736
Low Density	80	80
Read/Write Heads	2	2
Average Seek Time (Mb/s)		
Track-to-Track (high/low)	3/3	10
Average (high/low)	94/94	65/150
Latency Average (ms)	100	41.67

**Table 8-7
EIDE Hard Drives**


	630-MB	1.08-GB	1.2-GB
Formatted Capacity			
Physical (MB)		1089	1286
Logical (MB)	631.7	1089	1286
Compaq Spare Part Number			
	173114-001	243043-001	242990-001
Drive Type			
	65	65	65
Transfer Rate			
Interface (MBytes/sec)	22.9	16.7	16.7
Typical Seek Time (including settling)			
Single Track (ms)	5.0	3.0	5.0
Average (ms)	14.0	12.0	15.5
Full Stroke (ms)	34.0	22.0	30.0
Disk Rotational Speed (rpm)			
	3811	5378	5400
Cylinders			
Logical	1224	2100	2484
Data Heads			
Logical	16	16	16
Sectors per Track			
Logical	63	63	63
Buffer Size (KB)			
	128	128	128


 Because the Compaq Utilities are installed on a hidden partition on the hard drive, hard drive capacity will appear reduced when displayed by the computer.

continued

Table 8-7 *Continued*


	1.62-GB	2.5 GB
Formatted Capacity		
Physical (MB)	1629	2560
Logical (MB)	1629	2560
Compaq Spare Part Number		
	247411-001	242992-001
Drive Type		
	65	65
Transfer Rate		
Interface (MBytes/sec)	16.7	16.7
Typical Seek Time (including settling)		
Single Track (ms)	3.0	3.5
Average (ms)	12.0	15.5
Full Stroke (ms)	25.0	30.0
Disk Rotational Speed (rpm)		
	4480	4500
Cylinders		
Logical	3148	4969
Data Heads		
Logical	16	16
Sectors per Track		
Logical	63	63
Buffer Size (KB)		
	128	128

 The 2.5 GB hard drive is partitioned into two, equally sized, logical drives.

 Because the Compaq Utilities are installed on a hidden partition on the hard drive, hard drive capacity will appear reduced when displayed by the computer.

**Table 8-8
SCSI Hard Drives**

	1.0-GB	1.0-GB*	2.1-GB*
Formatted Capacity			
Physical (MB)	1083	1286	2149
Logical (MB)	1050	1286	2124
Compaq Spare Part Number			
	192799-001	247410-001	247409-001
Drive Type			
	SCSI	SCSI	SCSI
Transfer Rate			
Interface (MBytes/sec)	10.0	20.0	20.0
Typical Seek Time (including settling)			
Single Track (ms)	3.7	1.0	1.0
Average (ms)	10.5	10.5	10.5
Full Stroke (ms)	22.0	22.0	22.0
Disk Rotational Speed (rpm)			
	5400	5400	5400
Cylinders			
Physical	4903	4117	4117
Data Heads			
Logical	4	16	16
Sectors per Track			
Logical	32	63	63
Buffer Size (KB)			
	448	256	256

 Because the Compaq Utilities are installed on a hidden partition on the hard drive, hard drive capacity will appear reduced when displayed by the computer.

*Ultra-SCSI Hard Drives

Table 8-9
8X CD-ROM Drive

Applicable Disc	CD-ROM mode1, mode 2 Mixed mode (audio and data combined) CD-DA Photo CD (single and multi-session) CDi ready CD-XA ready
Disc Diameter	12 cm, 8 cm
Capacity	550 MB (Mode 1, 12 cm) 640 MB (Mode 2, 12 cm) 180 MB (8 cm)
Center Hole	15 mm diameter
Disc Thickness	1.2 mm
Track Pitch	1.6 μ m
Laser	
Beam Divergence	53.5 degrees +/- 1.5 degrees
Output Power	0.14 mW
Type	Semiconductor laser GaAlAs
Wave Length	790 nm +/- 25 nm
Access Time	
Random	150 ms
Full Stroke	350 ms
Audio Output Level	0.7V (RMS) (typical)
Cache Buffer	128 KB
Data Transfer Rate	
Sustained	1200 KB/sec
Burst	7.0 MB/sec

8.3 Mouse

**Table 8-10
Mouse**

	U.S.	Metric
Dimensions		
Height	1.34 in	3.4 cm
Length	4.45 in	11.3 cm
Width	2.36 in	6.0 cm
Weight	4.59 oz	130 g
Base Resolution	400 dpi	400 dpi
Tracking Speed (maximum)	10 in/sec	25 cm/sec
Temperature		
Operating	32°F to 104°F	0°C to 40°C
Storage	-4°F to 140°F	-20°C to 60°C
Lifetime		
Mechanical	Exceeds 300 miles	Exceeds 483 km
Switch	Exceeds 1 million operations	Exceeds 1 million operations
Relative Humidity	10% to 90%, noncondensing	10% to 90%, noncondensing
ESD	No soft errors through 10 kV; No hard errors through 15 kV; specific performance depends on host system	

8.4 Supported Graphics Resolutions

Table 8-11
Supported Graphics Resolutions

Cirrus Logic 5436 PCI Graphics Controller			
Resolution	1-MB DRAM Colors Supported	2-MB DRAM Colors Supported	
1280 × 1024	16	256	
1024 × 768	256	64K	
800 × 600	32K	16.7M	
640 × 480	64K	16.7M	

Cirrus Logic 5446 PCI Graphics Controller			
Resolution	1-MB DRAM Colors Supported	2-MB DRAM Colors Supported	
1280 × 1024	16	256	
1024 × 768	256	64K	
800 × 600	32K	16.7M	
640 × 480	64K	16.7M	

Matrox MGA Millennium Graphics Controller			
Resolution	2-MB WRAM Colors Supported	4-MB WRAM Colors Supported	8-MB WRAM Colors Supported
1600 × 1200	256	64K	16.7M
1280 × 1024	256	16.7M	16.7M
1152 × 864	64K	16.7M	16.7M
1024 × 768	64K	16.7M	16.7M
800 × 600	16.7M	16.7M	16.7M
640 × 480	16.7M	16.7M	16.7M


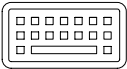
*Interlaced mode

appendix A


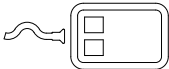
CONNECTOR PIN ASSIGNMENTS

This appendix contains the pin assignments for all external connectors:

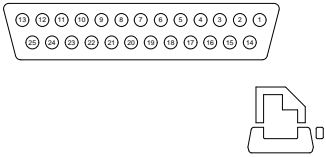
**Table A-1
Keyboard**

Connector and Icon	Pin	Signal
 	1	Data
	2	Unused
	3	Ground
	4	+5 VDC
	5	Clock
	6	Unused

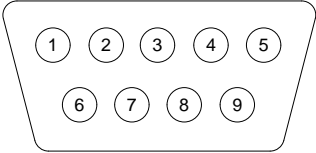
**Table A-2
Mouse**

Connector and Icon	Pin	Signal
 	1	Data
	2	Unused
	3	Ground
	4	+5 VDC
	5	Clock
	6	Unused

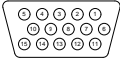

**Table A-3
Parallel Interface**

Connector and Icon	Pin	Signal
	1	Strobe#
	2	Data Bit 0
	3	Data Bit 1
	4	Data Bit 2
	5	Data Bit 3
	6	Data Bit 4
	7	Data Bit 5
	8	Data Bit 6
	9	Data Bit 7
	10	Acknowledge#
	11	Busy
	12	Paper End
	13	Select
	14	Auto Linefeed#
	15	Error#
	16	Initialize Printer#
	17	Select IN#
	18-25	Signal Ground

**Table A-4
Serial Interface**

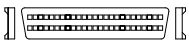

Connector	Pin	Signal
	1	Carrier Detect
	2	Receive Data#
	3	Transmit Data#
	4	Data Terminal Ready
	5	Signal Ground
	6	Data Set Ready
	7	Request to Send
	8	Clear to Send
	9	Ring Indicator

**Table A-5
VGA Monitor**

Connector and Icon		Pin	Signal
 		1	Red Analog
		2	Green Analog
		3	Blue Analog
		4	Monitor ID Bit2
		5	Ground
		6	Ground Analog
		7	Ground Analog
		8	Ground Analog
		9	Not Connected
		10	Ground
		11	Monitor ID Bit 0
		12	Bi-directional Data (SDA)*
		13	Horizontal Sync
		14	Vertical Sync
		15	Data Clock (SCL)*

* For DDC support (I²C monitors)

**Table A-6
Ultra SCSI Connector**

Connector and Icon	Pin	Signal
 	1-11	Ground
	12	Reserved
	13	Open
	14	Reserved
	15-25	Ground
	26	DBO
	27	DB1
	28	DB2
	29	DB3
	30	DB4
	31	DB5
	32	DB6
	33	DB7
	34	DBP
	35	Ground
	36	Ground
	37	Reserved
	38	TERMPWR
	39	Reserved
	40	Ground
	41	ATN #
	42	Ground
	43	BSY #
	44	ACK #
	45	RST #
46	MSG #	
47	SEL #	
48	C/D	
49	REQ #	
50	Input/Output	

**Table A-7
Line in-Connector**

Connector and Icon



1/8-inch Miniphone

**Table A-8
Line out-Connector**

Connector and Icon



1/8-inch Miniphone

**Table A-9
Microphone Connector**

Connector and Icon



Stereo 1/8-inch Miniphone

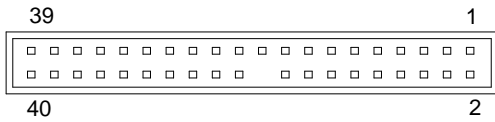
**Table A-10
Headphone Connector**

Connector and Icon



Stereo 1/8-inch Miniphone

**Table A-11
CD-ROM Data Cable**



Pin	Signal	Pin	Signal
1	RESET#	21	DREQ
2	GND	22	GND
3	DD7	23	DIOW#
4	DD8	24	GND
5	DD6	25	DIOR#
6	DD9	26	GND
7	DD5	27	IORDY
8	DD10	28	CABLE SELECT#
9	DD4	29	DMACK#
10	DD11	30	GND
11	DD3	31	INTRQ
12	DD12	32	IOCS16#
13	DD2	33	DA1
14	DD13	34	PDIAG#
15	DD1	35	DA0
16	DD14	36	DA2
17	DD0	37	CS1FX#
18	DD15	38	CS3FX#
19	GND	39	DASP#
20	(KEY)	40	GND

appendix **B**

POWER CORD SET REQUIREMENTS

The voltage select switch feature on the computer permits it to operate from any line voltage between 100-120 or 220-240 volts AC.

The power cord set received with the computer meets the requirements for use in the country where you purchased the equipment.

Power cord sets for use in other countries must meet the requirements of the country where you use the computer. For more information on power cord set requirements, contact your authorized Compaq dealer, reseller or service provider.

General Requirements

The requirements listed below are applicable to all countries:

1. The length of the power cord set must be at least 6.00 feet (1.8 m) and a maximum of 9.75 feet (3.0 m).
2. All power cord sets must be approved by an acceptable accredited agency responsible for evaluation in the country where the power cord set will be used.
3. The power cord set must have a minimum current capacity of 10A and a nominal voltage rating of 125 or 250 volts AC, as required by each country's power system.
4. The appliance coupler must meet the mechanical configuration of an EN 60 320/IEC 320 Standard Sheet C13 connector, for mating with appliance inlet on the Switch Box.

Country-Specific Requirements

Power Cord Set Requirements—By Country		
Country	Accredited Agency	Applicable Note Numbers
Australia	EANSW	1
Austria	OVE	1
Belgium	CEBC	1
Canada	CSA	2
Denmark	DEMKO	1
Finland	SETI	1
France	UTE	1
Germany	VDE	1
Italy	IMQ	1
Japan	JIS	3
Norway	NEMKO	1
Sweden	SEMKO	1
Switzerland	SEV	1
United Kingdom	BSI	1
United States	UL	2

NOTES:

1. The flexible cord must be <HAR> Type HO5VV-F, 3-conductor, 1.0 mm² conductor size. Power cord set fittings (appliance coupler and wall plug) must bear the certification mark of the agency responsible for evaluation in the country where it will be used.
2. The flexible cord must be Type SJT or equivalent, No. 18 AWG, 3-conductor. The wall plug must be a two-pole grounding type with a NEMA 5-15P (15A, 125V) or NEMA 6-15P (15A 250V) configuration.
3. The appliance coupler, flexible cord, and wall plug must bear a "T" mark and registration number in accordance with the Japanese Dentori Law. The flexible cord must be Type VCT or VCTF, 3-conductor, 0.75 mm² conductor size. The wall plug must be a two-pole grounding type with a Japanese Industrial Standard C8303 (15A, 125V) configuration.

appendix C

HARD DRIVES

Compaq Computer Corporation uses IDE hard disk drives that conform to two different primary/secondary implementations. These are Conner mode and ATA-compatible mode. These two modes are incompatible with one another.

Device 0/Device 1 Relationship

A device 0/device 1 relationship exists when there are two hard drives connected to a single port. In this situation, one drive must be designated as the device 0, or primary, drive and the other as the device 1, or secondary, drive. This designation is necessary because both drives cannot work simultaneously.

Cable Select

The Compaq Deskpro 2000 Series of Personal Computers use cable-select technology for identifying Device 0 (primary) and Device 1 (secondary) IDE hard drives. Check that the jumpers on the IDE hard drive are set properly for cable-select installation. Always check the label on the drives or check Chapter 6 of this manual when a new drive is added to verify that the jumper settings are set correctly.

- Cable select may not function properly if drives other than those supported by Compaq are installed.
- The second drive on a cable-select cable can be a CD-ROM drive. However, the CD-ROM drive must be installed in the device 1 position if a hard drive is installed on the same cable. Ensure that both drives are set for cable-select configuration. See Chapter 6 for more information.
- If two drives are already connected to the primary IDE controller and an additional drive is to be installed, the secondary IDE controller must be enabled. The secondary IDE controller can be enabled by checking this option after opening the Advanced box in the Mass Storage group of F10 Computer Setup. See Chapter 7 for more information.
- When more than two drives are installed, drive performances are best when the two faster drives are connected to the primary IDE controller and the slower drive is connected to the secondary IDE controller.
- A hard drive is installed and configured more quickly when it has first been formatted.
- If your new drive includes the cable select feature, no jumper setting changes are required. Refer to the documentation supplied with the cable for instructions on using the cable select feature. If you install a third-party hard drive, you will need to purchase a jumper cable (spare part number 247568-001) from Compaq Computer Corporation.

IntelliSafe - SMART

The IntelliSafe IDE hard drives for the Compaq Deskpro 2000 Series of Personal Computers have built-in drive failure prediction that warns the user or the network administrator of an impending failure or crash of the hard drive.

Automatic Soft-Drive Types

An automatic soft-drive type is a mechanism where the system ROM and Computer Setup provide support for IDE hard drives that are not supported in the hard drive parameter table. Computer Setup automatically builds a soft-drive type when it finds that a hard drive is not in the hard drive parameter table.

The soft-drive types assign according to the table below:

Table C-1
Soft-Drive Type Assignments

Drive	Hard Drive Type	Controller
0	65	Primary
1	66	Primary
0	68	Secondary
1	15	Secondary

For hard drives that are greater than 528 MB, the system automatically translates the hard drive parameter for DOS by logically halving the cylinders and doubling the heads. This allows DOS to access greater than 528 MB. The translated hard drive parameters are put into the hard drive parameter table in the shadow RAM copy of the system ROM. When using any operating system other than DOS, you must use the Compaq User Diagnostic diskette to set up the hard drive parameter table without translation.